

Chartley

Deck Box Metal Storage Assembly Guide



IMPORTANT: PLEASE REGISTER YOUR HEX LIVING PRODUCT BEFORE ASSEMBLY

Using the unique serial number, simply register your product at www.hexliving.co.uk to access and download the HEX Living lifetime warranty and video assembly instructions.

Affix Serial Number
HERE



PLEASE READ THIS DOCUMENT FULLY PRIOR TO STARTING ASSEMBLY PROCEDURE

The objective of this instruction is to illustrate the recommended assembly sequence for this product, any deviation from this will be the sole responsibility of whoever carries out the assembly.

IMPORTANT: IT IS ADVISABLE THAT THE PRODUCT IS ASSEMBLED AT, OR AS CLOSE AS POSSIBLE TO WHERE IT WILL BE FINALLY LOCATED

Ensure there is adequate clearance where the product is to be located:

Exterior dimensions including overhang (W x D x H)	1353 x 653 x 635mm
Footprint dimensions (W x D)	1303 x 603mm
Clearance required for Lid to open (W x H)	653 x 1202mm

SINGLE PERSON ASSEMBLY

Most procedures will not require two people but it may be easier to have assistance.



PERSONAL PROTECTION EQUIPMENT

We advise appropriate personal protective equipment is worn during assembly including eye protection and gloves.



Eye Protection



Gloves

CARING FOR YOUR HEX LIVING PRODUCT

Your HEX Living product is designed to stand the test of time, which is why we're happy to offer a lifetime warranty on our products. With zero maintenance required, simply assemble your HEX Living product and enjoy putting it to great use in your garden.

Periodically, you might want to give your product a clean, these simple care tips are not essential to the performance of your product:

- Remove surface dirt with plain water using a jet wash or sponge, the coating on our products will ensure dirt or mud simply wipes away.
- Periodically clear the lid of fallen leaves.
- If your product has guttering, remove leaves and garden debris as you would on your home.

PRODUCT REGISTRATION

IMPORTANT: Prior to assembly, please ensure you have registered your HEX Living product using the unique serial number found on the cover of this document, please visit www.hexliving.co.uk to register your product and access the HEX Living lifetime warranty and video instructions.

ENSURE ALL ITEMS LISTED ARE PRESENT PRIOR TO STARTING ASSEMBLY PROCEDURE
SCALE OF ITEMS WILL VARY TO AID VISUAL IDENTIFICATION

Part Ref: 0206-01
Qty: x2

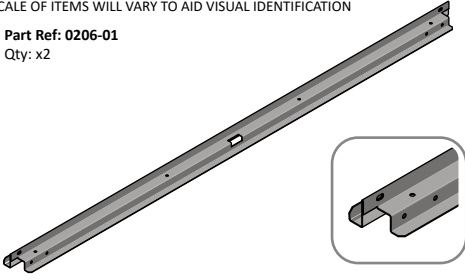

Part Ref: 0206-02
Qty: x2

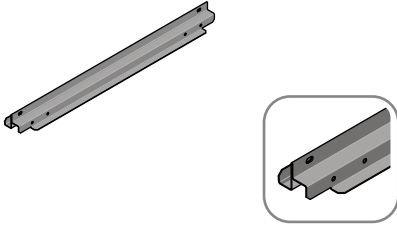

Part Ref: 0206-37
Qty: x1

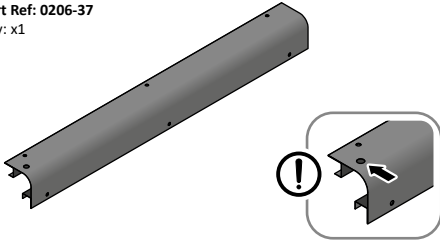

Part Ref: 0206-38
Qty: x1

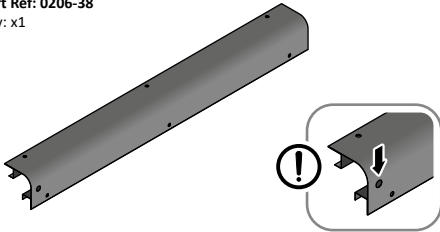

Part Ref: 0206-36
Qty: x2

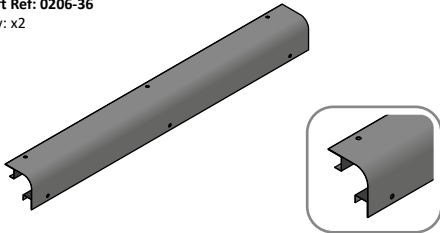

Part Ref: 0206-05
Qty: x1

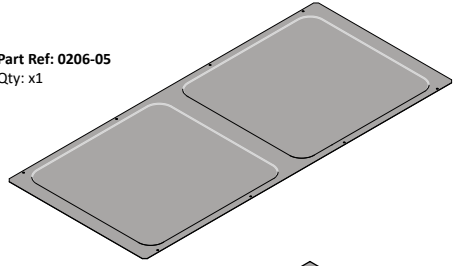

Part Ref: 0206-33
Qty: x1

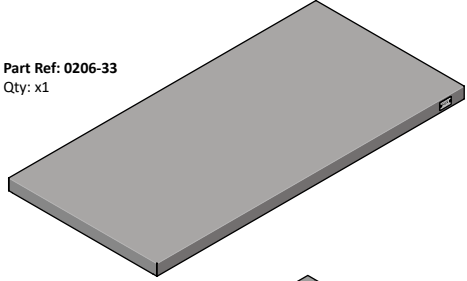

Part Ref: 0206-08
Qty: x1

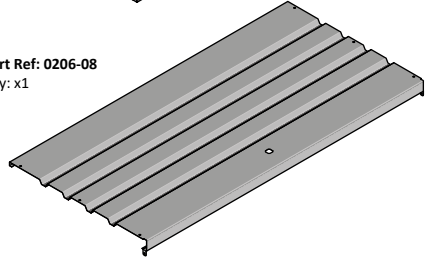

Part Ref: 0206-09
Qty: x2

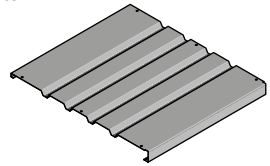

Part Ref: 0206-10
Qty: x1

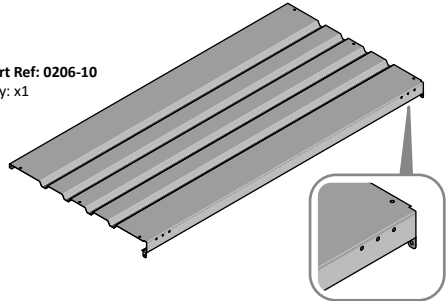

ENSURE ALL ITEMS LISTED ARE PRESENT PRIOR TO STARTING ASSEMBLY PROCEDURE
SCALE OF ITEMS WILL VARY TO AID VISUAL IDENTIFICATION

Part Ref: 0206-07
Qty: x1

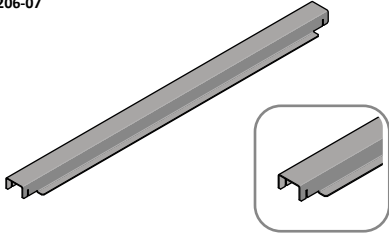

Part Ref: 0203-03
Qty: x4

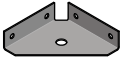

Part Ref: 0206-39
Qty: x2



Part Ref: 0206-29
Qty: x2

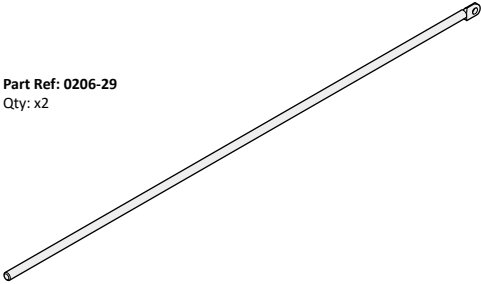

Part Ref: 0206-18
Qty: x2

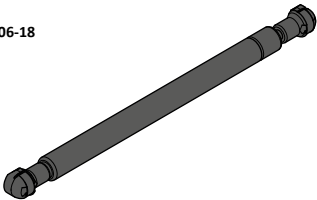

Part Ref: 0205-68
Qty: x4



Part Ref: 0206-19 (Assembly)
Qty: x1

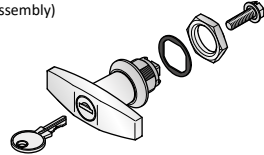

Part Ref: 0206-28 (Assembly)
Qty: x1

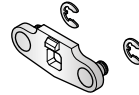

Part Ref: 0204-30
Qty: x4



FIXING KIT: 0206-31

Part Ref: FK1
M4 x 8mm Roofing Bolt
Qty: x63



Part Ref: FK2
M4 x 12mm C'Sunk Pozzi Pan
Qty: x7



Part Ref: FK3
M4 Serrated Flange Nut
Qty: x69



Part Ref: FK4
M8 Serrated Flange Nut
Qty: x5



ASSEMBLY STAGE 1

LOCATE AND SECURE A CORNER BRACE 0203-03 AT EACH LOCATION INDICATED.

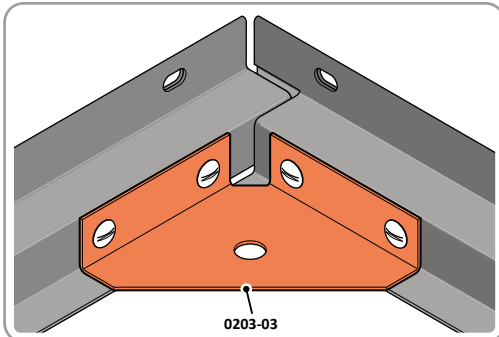
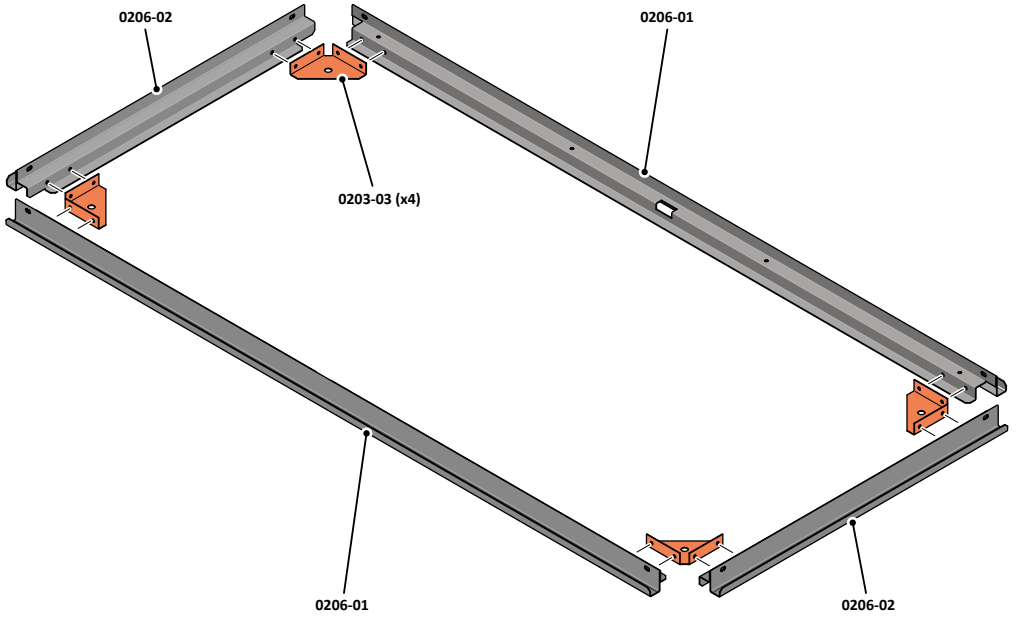

SECURE EACH CORNER BRACE 0203-03 AS SHOWN ABOVE.

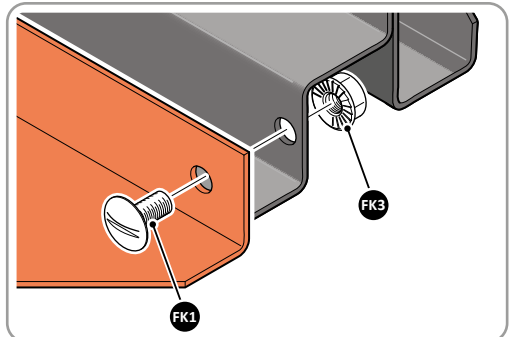

PLEASE NOTE: SECTION VIEW OF TYPICAL FIXING METHOD.

ASSEMBLY STAGE 2

LOCATE AND SECURE FLOOR BRACE 0206-07 AT LOCATION INDICATED.

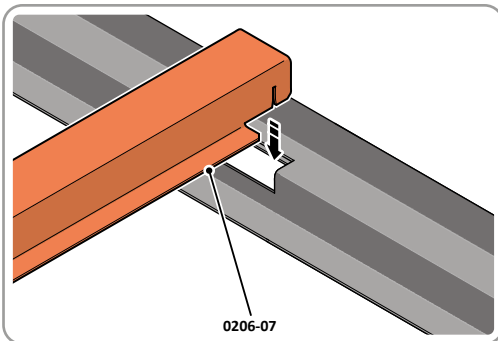
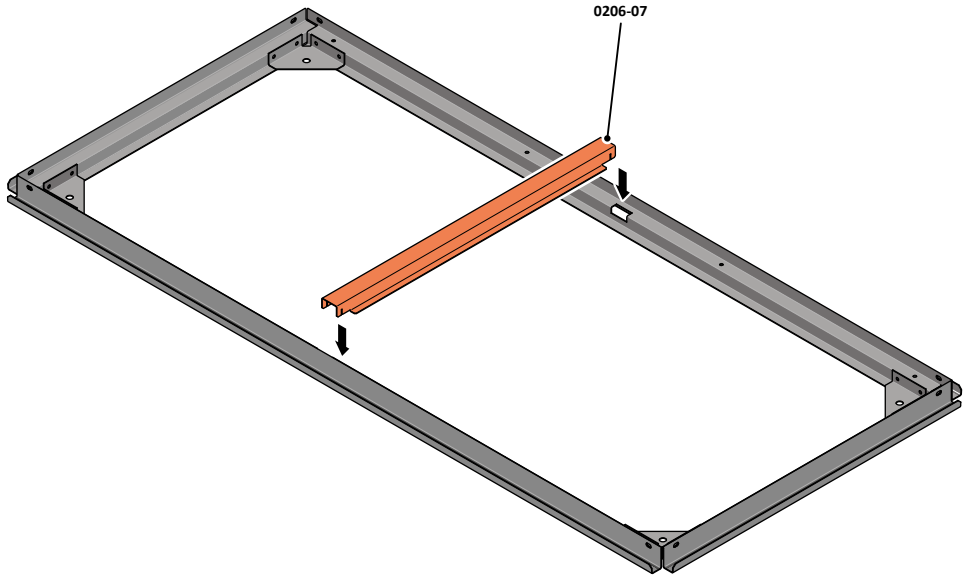

SLOT FLOOR BRACE 0206-07 INTO POSITION AS SHOWN ABOVE.

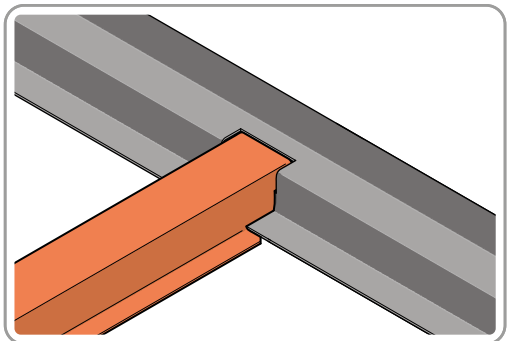

PLEASE NOTE: ENSURE TOP OF FLOOR BRACE IS LEVEL WITH TOP OF FLOOR RAIL.

ASSEMBLY STAGE 3

LOCATE AND SECURE FLOOR PANEL 0206-05 AS SHOWN.

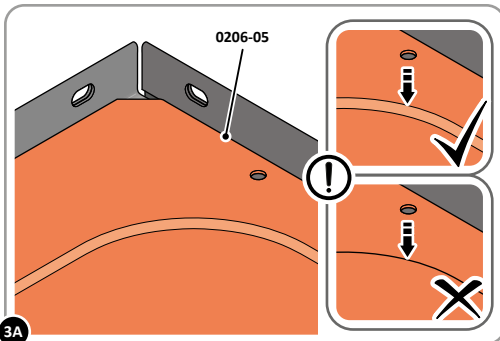
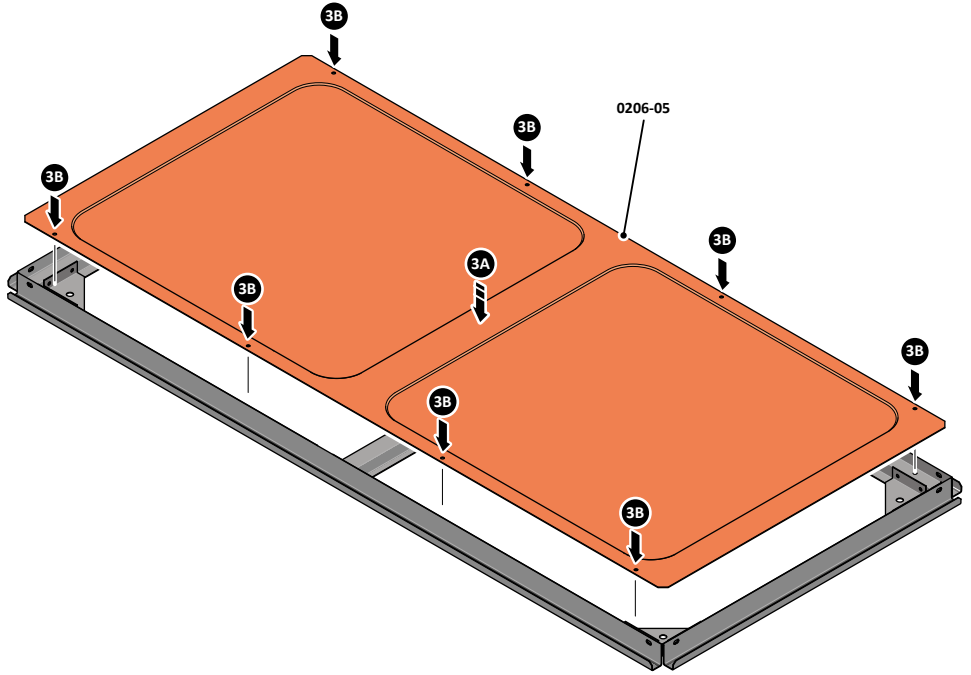

3A LOCATE FLOOR PANEL 0206-05 INTO POSITION AS SHOWN ABOVE.

⚠ ENSURE PANEL IS IN CORRECT ORIENTATION WITH RECESS FACING DOWN.

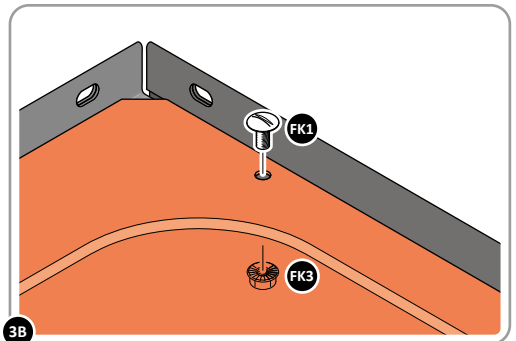

3B SECURE FLOOR PANEL AT EACH LOCATION INDICATED AS SHOWN.

ASSEMBLY STAGE 4

LOCATE AND LOOSELY ATTACH CORNER POSTS 0206-37 & 0206-38 AT EACH LOCATION SHOWN.

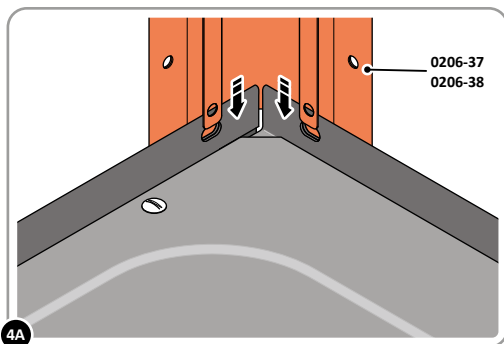
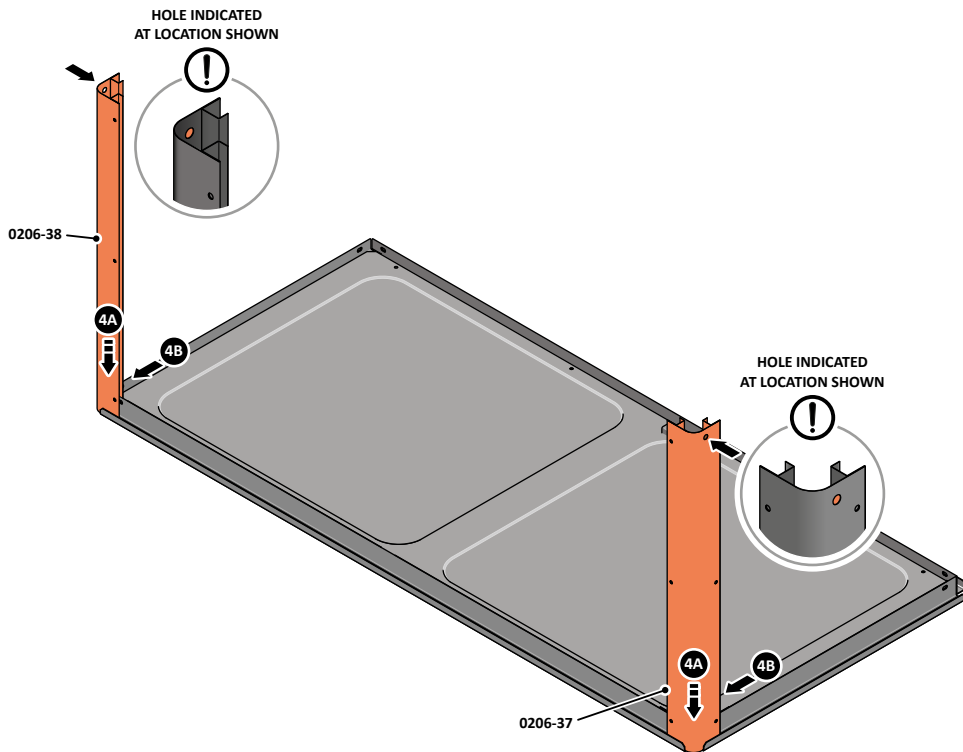

SLIDE EACH CORNER POST 0206-37 & 0206-38 INTO POSITION AS SHOWN ABOVE.

⚠ ENSURE CORNER POSTS ARE LOCATED AS DETAILED IN MAIN DIAGRAM.

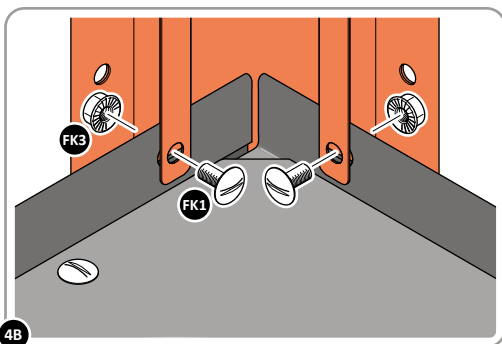

LOOSELY ATTACH EACH CORNER POST AS SHOWN ABOVE.

ASSEMBLY STAGE 5

LOCATE AND SECURE A BOTTOM GAS STRUT BRACKET 0206-39 AT EACH LOCATION INDICATED.

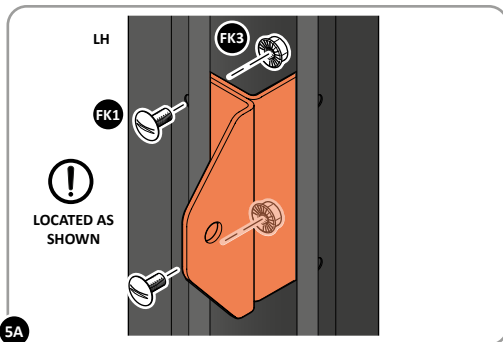
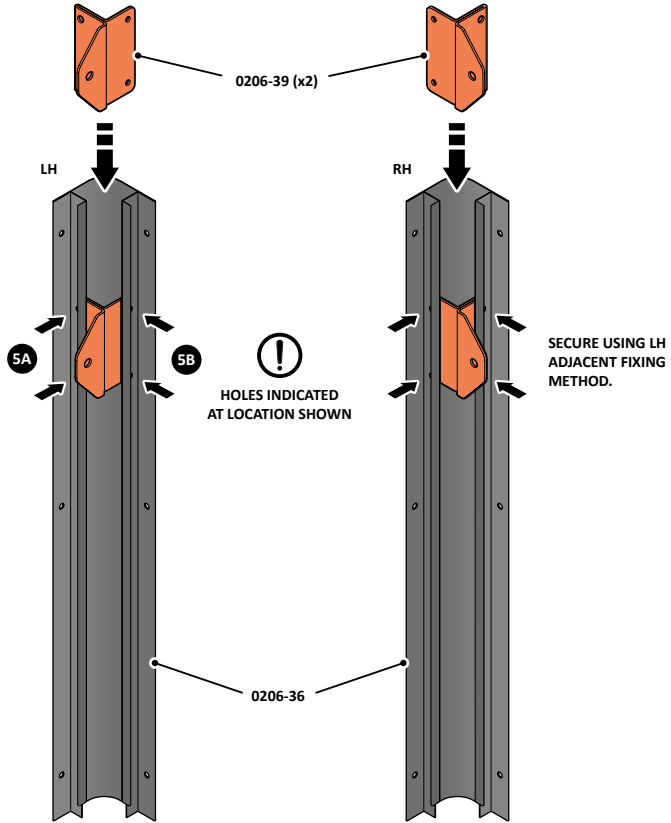

5A SECURE BOTTOM GAS STRUT BRACKET 0206-39 AS SHOWN.

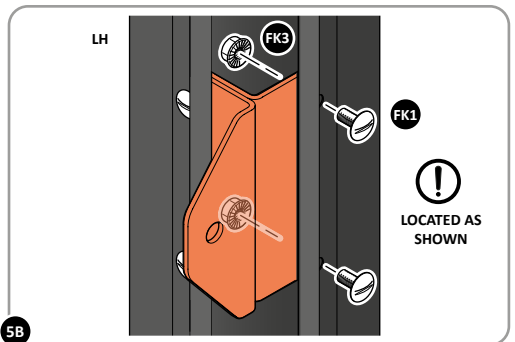

5B SECURE BOTTOM GAS STRUT BRACKET 0206-39 AS SHOWN.

ASSEMBLY STAGE 6

LOCATE AND LOOSELY ATTACH CORNER POSTS 0206-36 AT EACH LOCATION SHOWN.

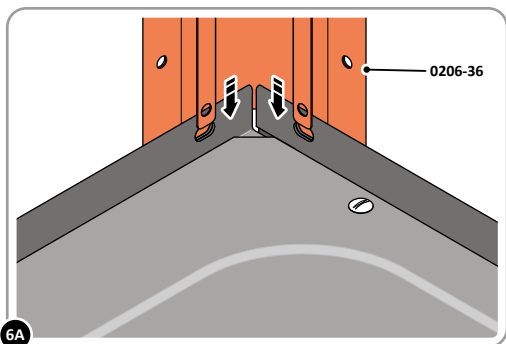
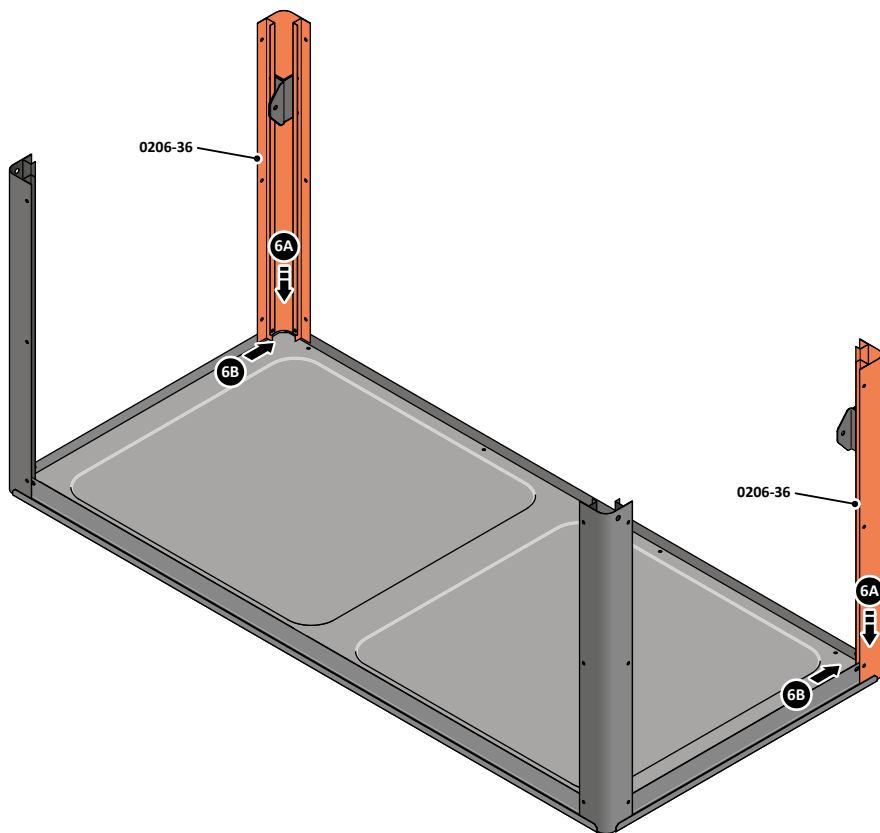

6A SLIDE EACH CORNER POST 0206-36 INTO POSITION AS SHOWN ABOVE.

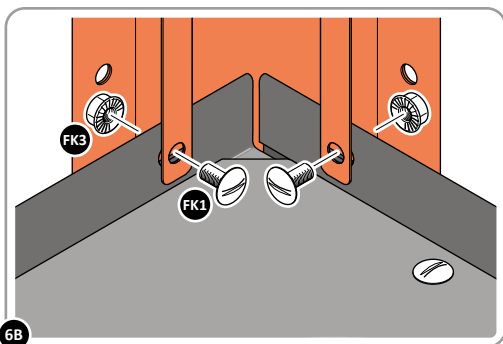

6B LOOSELY ATTACH EACH CORNER POST AS SHOWN ABOVE.

ASSEMBLY STAGE 7

LOCATE AND LOOSELY ATTACH FRONT PANEL 0206-08 AS SHOWN.

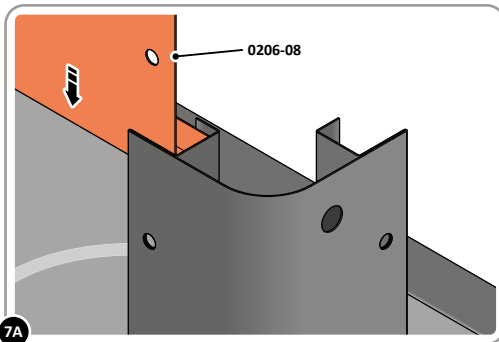
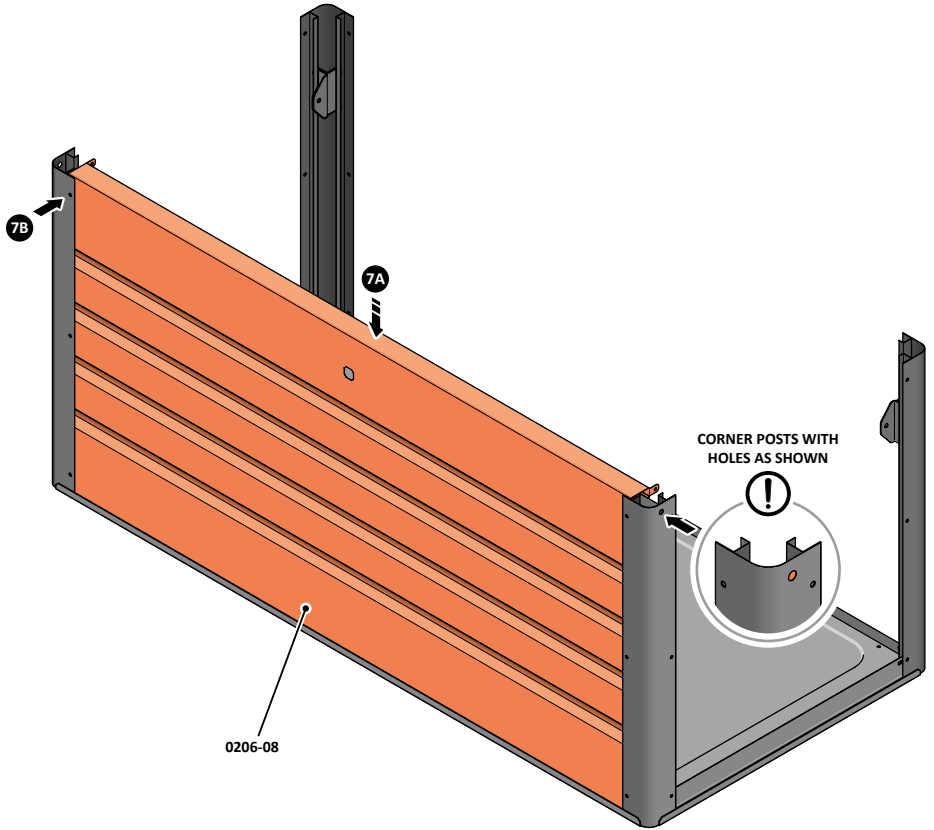

7A SLIDE FRONT PANEL 0206-08 INTO POSITION AS SHOWN ABOVE.

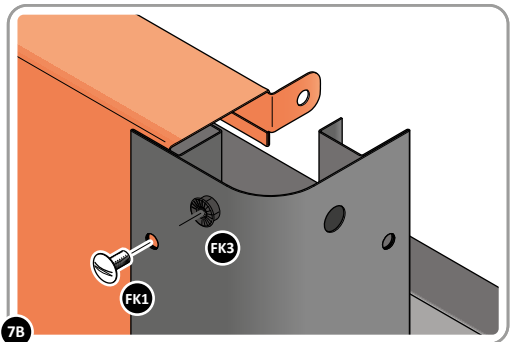

7B LOOSELY ATTACH FRONT PANEL AT EACH LOCATION INDICATED AS SHOWN.

ASSEMBLY STAGE 8

LOCATE AND LOOSELY ATTACH REAR PANEL 0206-10 AS SHOWN.

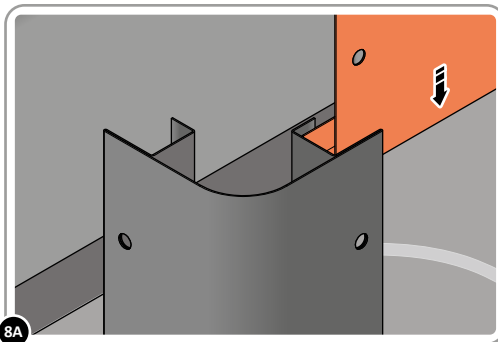
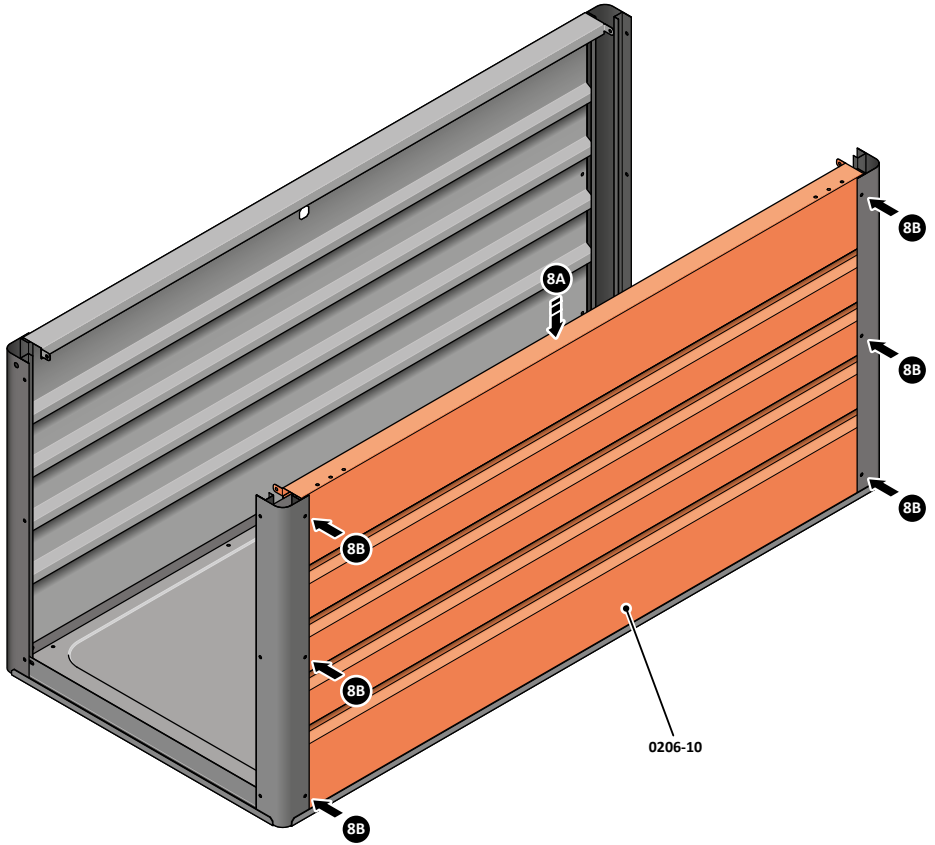

SLIDE REAR PANEL 0206-10 INTO POSITION AS SHOWN ABOVE.

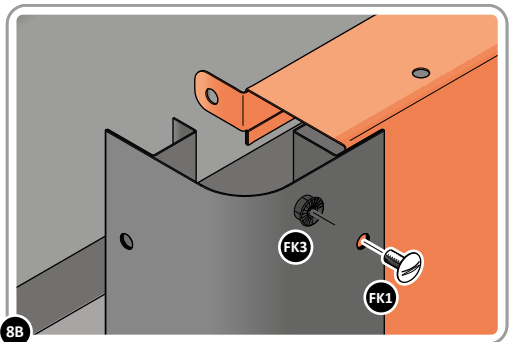

LOOSELY ATTACH REAR PANEL AT EACH LOCATION INDICATED AS SHOWN.

ASSEMBLY STAGE 9

LOCATE AND LOOSELY ATTACH SIDE PANEL 0206-09 AS SHOWN.

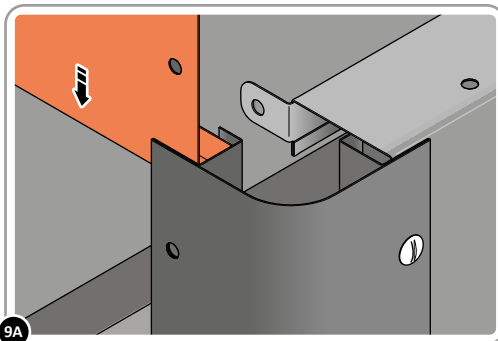
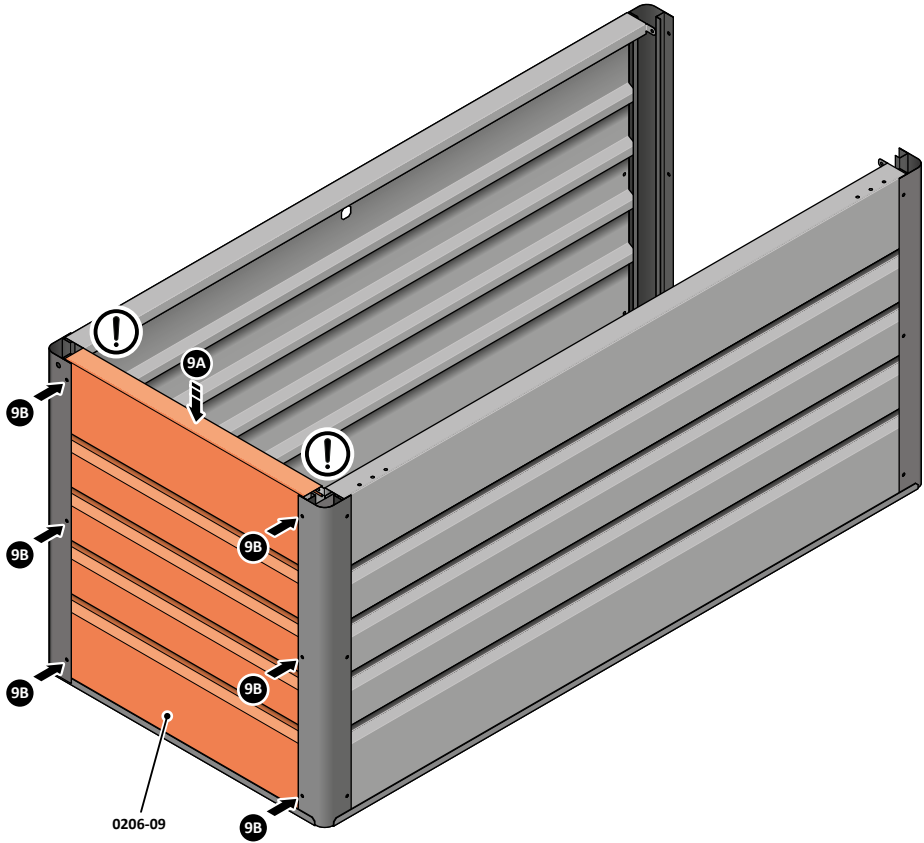

9A SLIDE SIDE PANEL 0206-09 INTO POSITION AS SHOWN ABOVE.

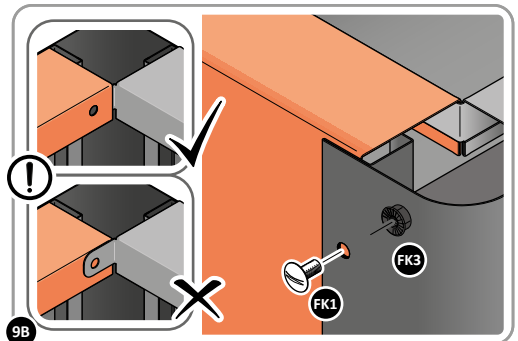

9B LOOSELY ATTACH SIDE PANEL AT EACH LOCATION INDICATED AS SHOWN.

⚠ ENSURE FRONT & REAR PANEL TABS ARE LOCATED AS SHOWN BEFORE SECURING.

ASSEMBLY STAGE 10

LOCATE AND LOOSELY ATTACH SIDE PANEL 0206-09 AS SHOWN.

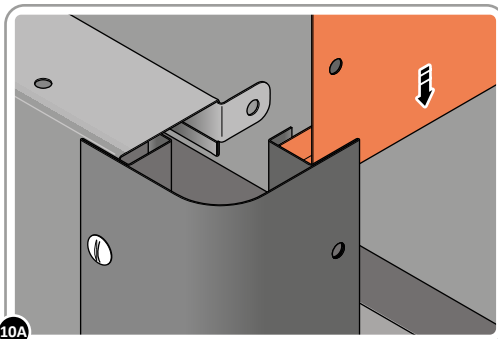
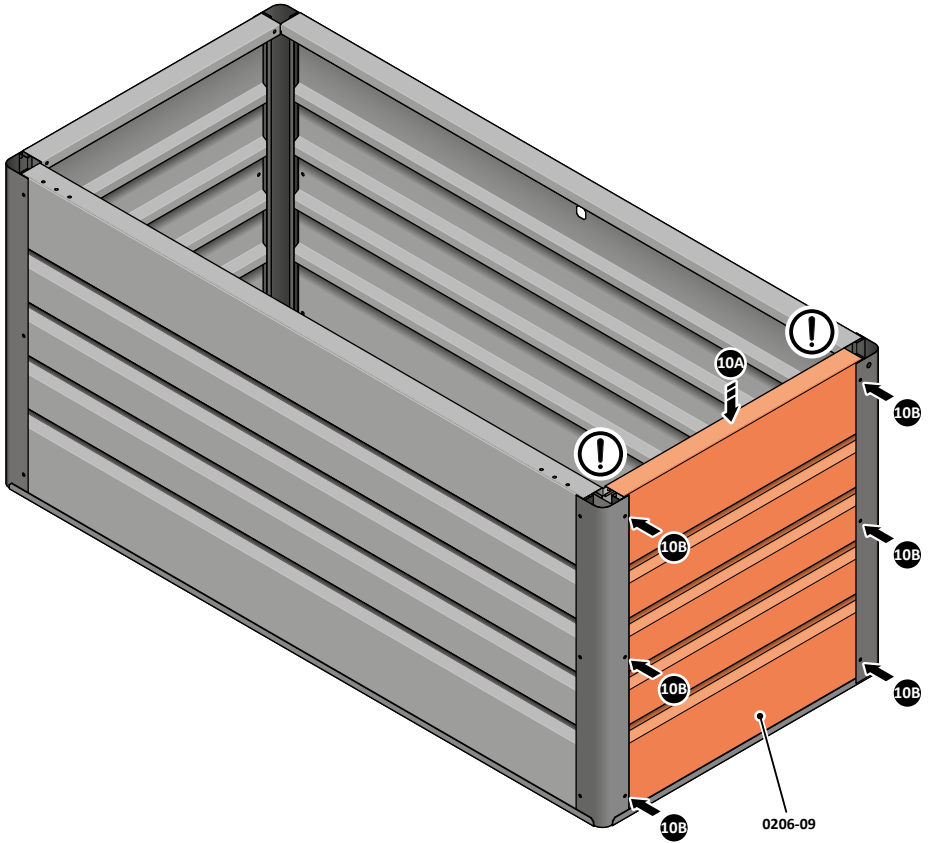

10A SLIDE SIDE PANEL 0206-09 INTO POSITION AS SHOWN ABOVE.

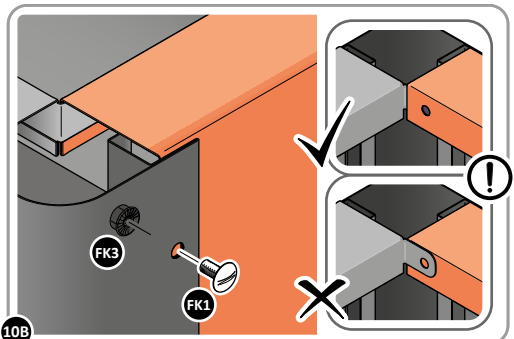

10B LOOSELY ATTACH SIDE PANEL AT EACH LOCATION INDICATED AS SHOWN.

⚠ ENSURE FRONT & REAR PANEL TABS ARE LOCATED AS SHOWN BEFORE SECURING.

ASSEMBLY STAGE 11

LOCATE AND LOOSELY ATTACH SIDE PANEL 0206-09 AS SHOWN.

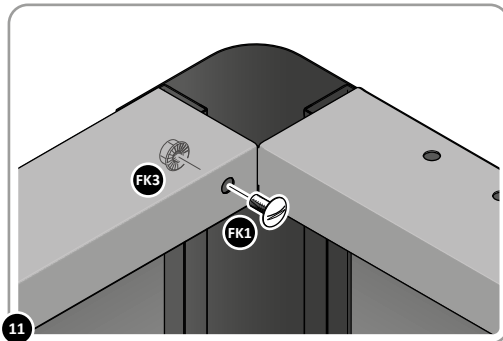
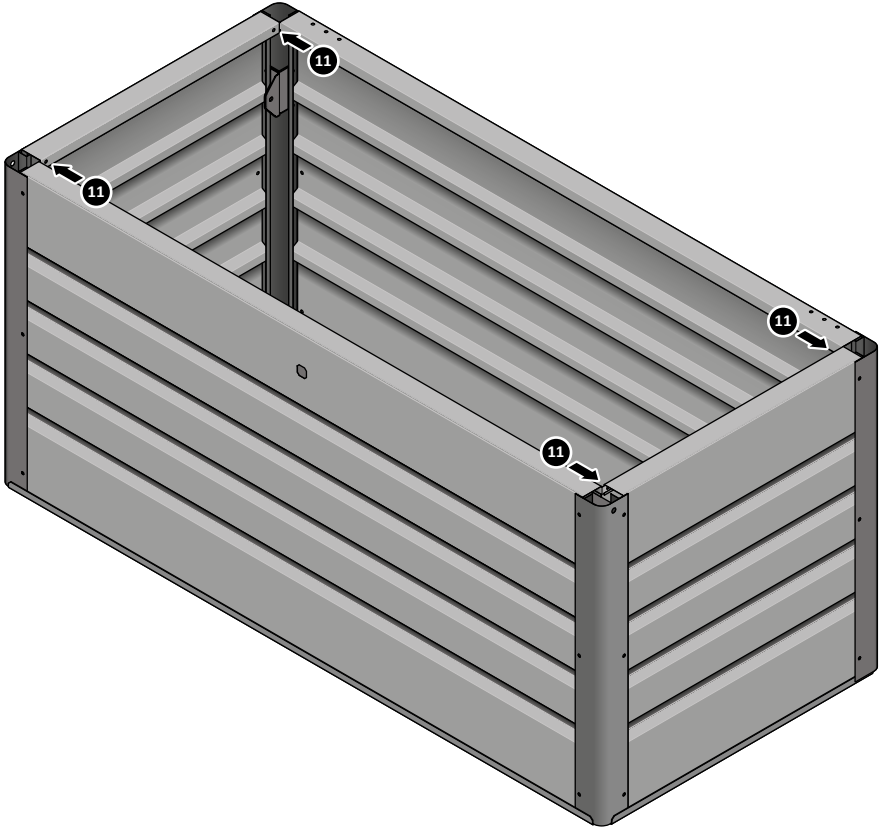

LOOSELY ATTACH SIDE PANELS ONTO FRONT AND REAR PANELS AT x4 LOCATIONS INDICATED USING TYPICAL FIXING METHOD ABOVE.

ASSEMBLY STAGE 12

LOCATE AND SECURE T-HANDLE 0206-19 AS SHOWN.

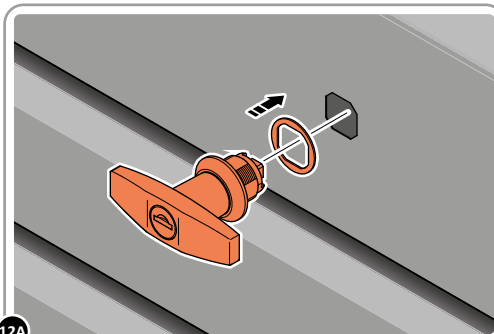
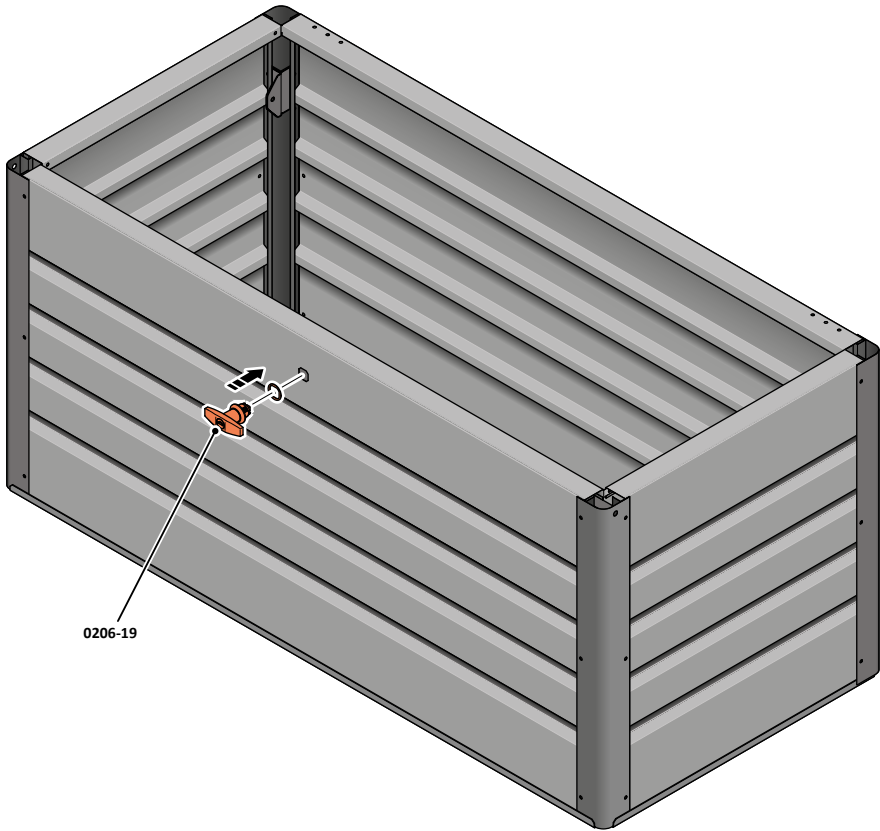

12A

LOCATE T-HANDLE AND T-HANDLE GASKET (PART OF 0206-19 ASSEMBLY) INTO FRONT PANEL APERTURE AS SHOWN.

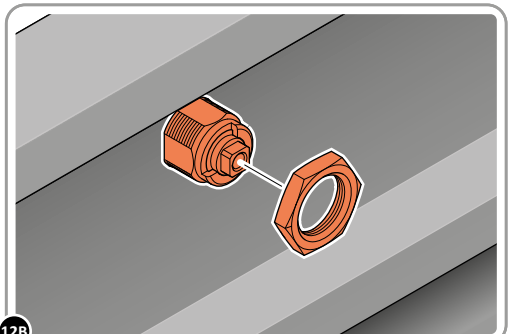

12B

SECURE T-HANDLE USING T-HANDLE ASSEMBLY NUT AS SHOWN.

ASSEMBLY STAGE 13

LOCATE AND SECURE 2 POINT CAM 0206-28 AS SHOWN.

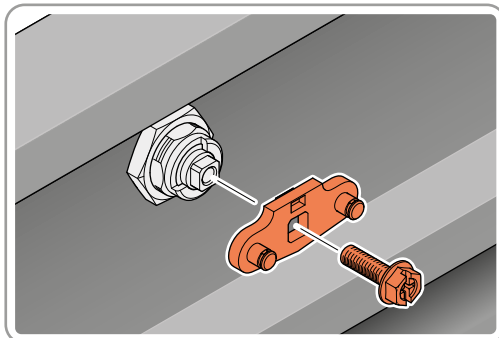
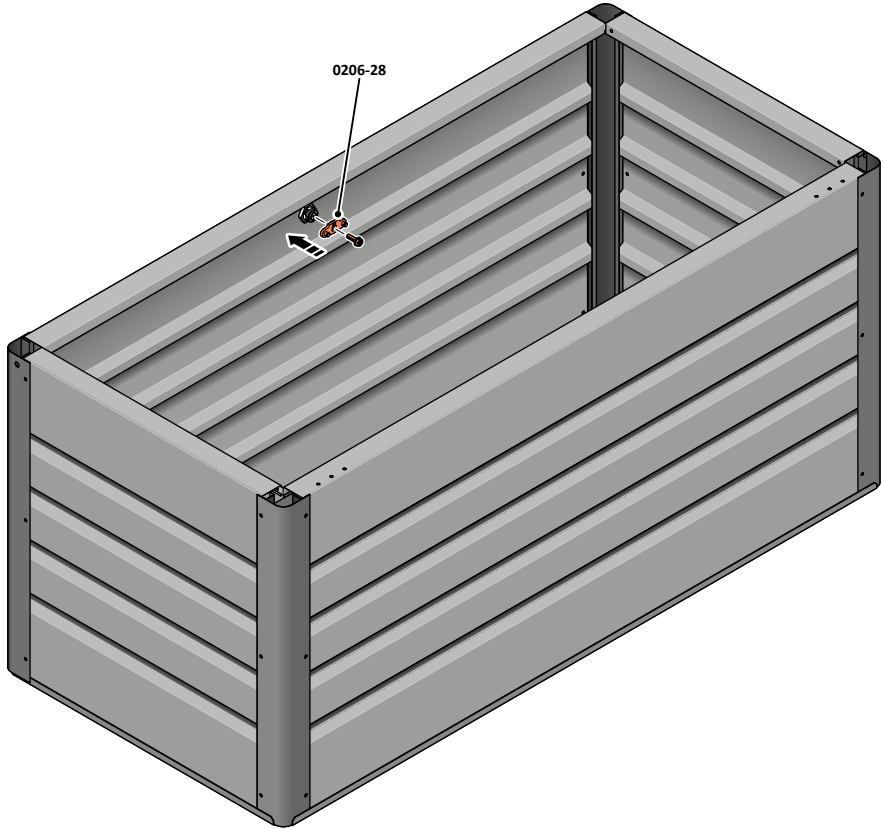

SECURE 2 POINT CAM 0206-28 ONTO T-HANDLE USING BOLT SHOWN ABOVE FROM T-HANDLE ASSEMBLY.

ASSEMBLY STAGE 14

LOCATE AND SECURE RODS 0206-29 AS SHOWN.

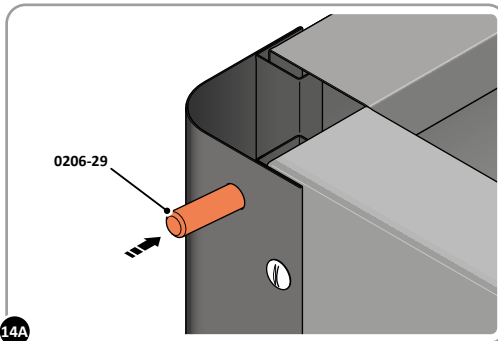
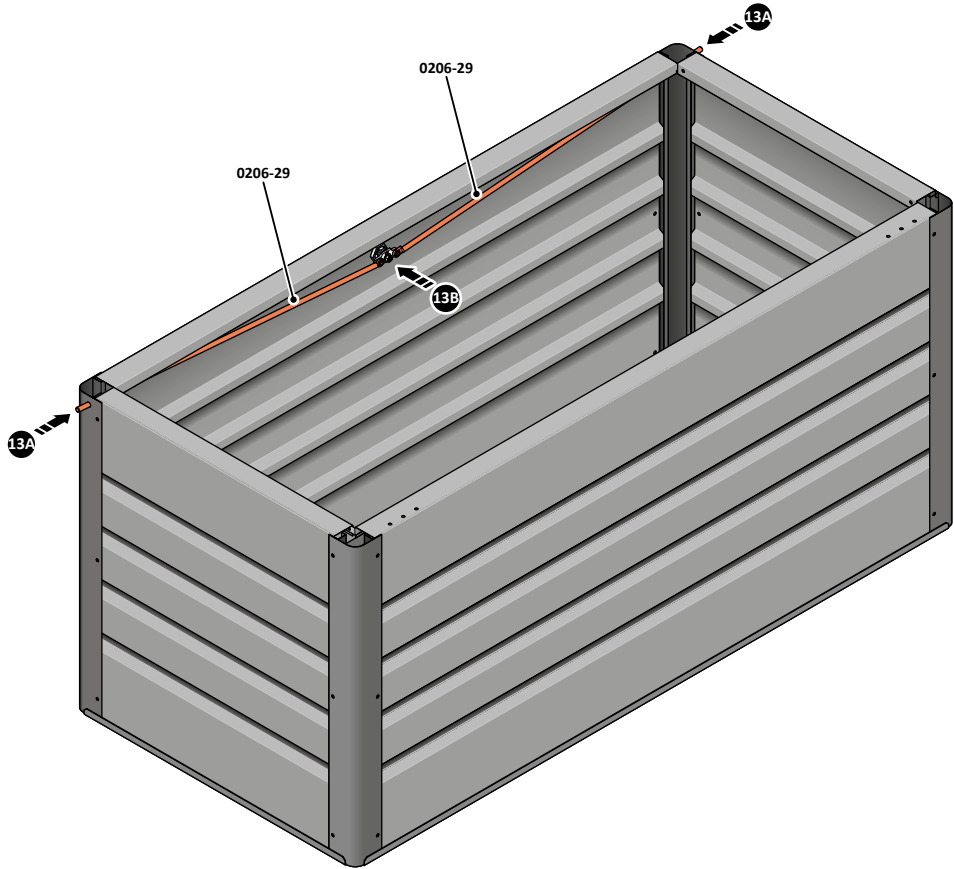

LOCATE RODS 0206-29 INTO CORNER POST APERTURES AS SHOWN.

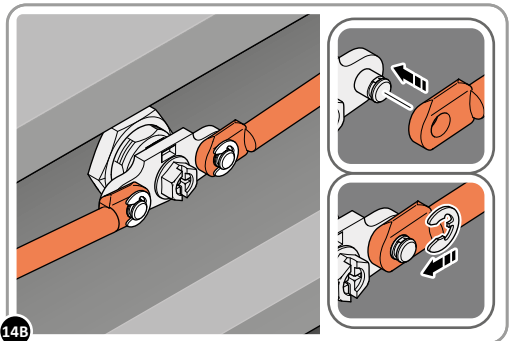

SECURE ROD ONTO 2 POINT CAM USING E-CLIPS (PART OF 0206-28 ASSEMBLY).

ASSEMBLY STAGE 15

SECURE BALL STUD 0205-68 ONTO EACH BOTTOM GAS STRUT BRACKET 0206-39.

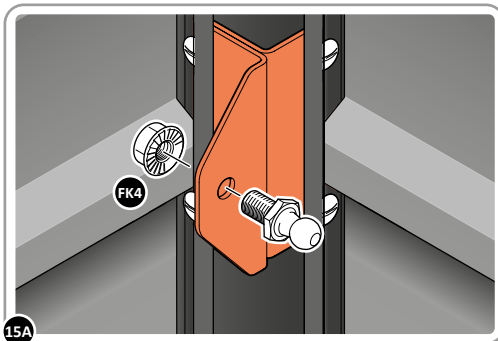
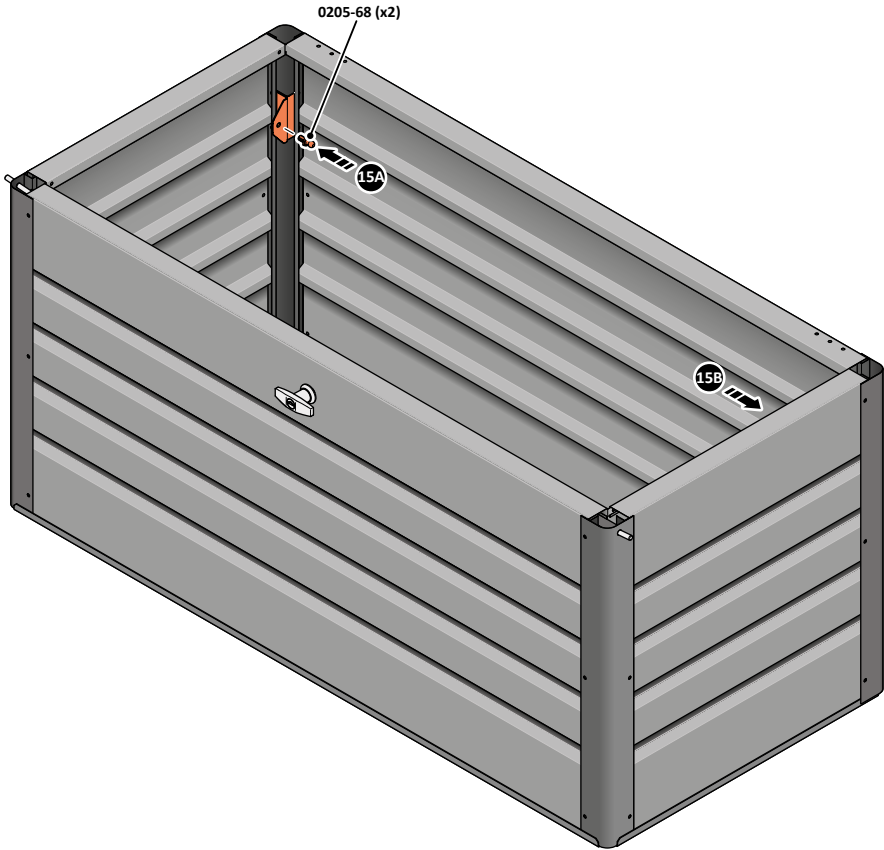

15A SECURE BALL STUD 0205-68 ONTO BOTTOM GAS STRUT BRACKET AS SHOWN.

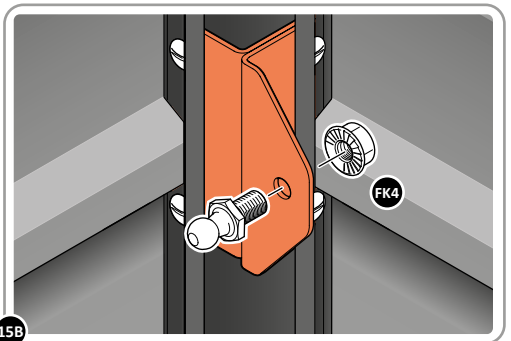

15B SECURE BALL STUD 0205-68 ONTO BOTTOM GAS STRUT BRACKET AS SHOWN.

ASSEMBLY STAGE 16

LOCATE AND SECURE LID ASSEMBLY 0206-33



MAY FIND BENEFICIAL
WHEN SECURING 0206-33
TO FRAME ASSEMBLY

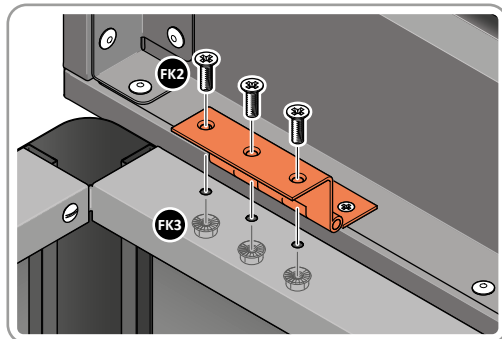
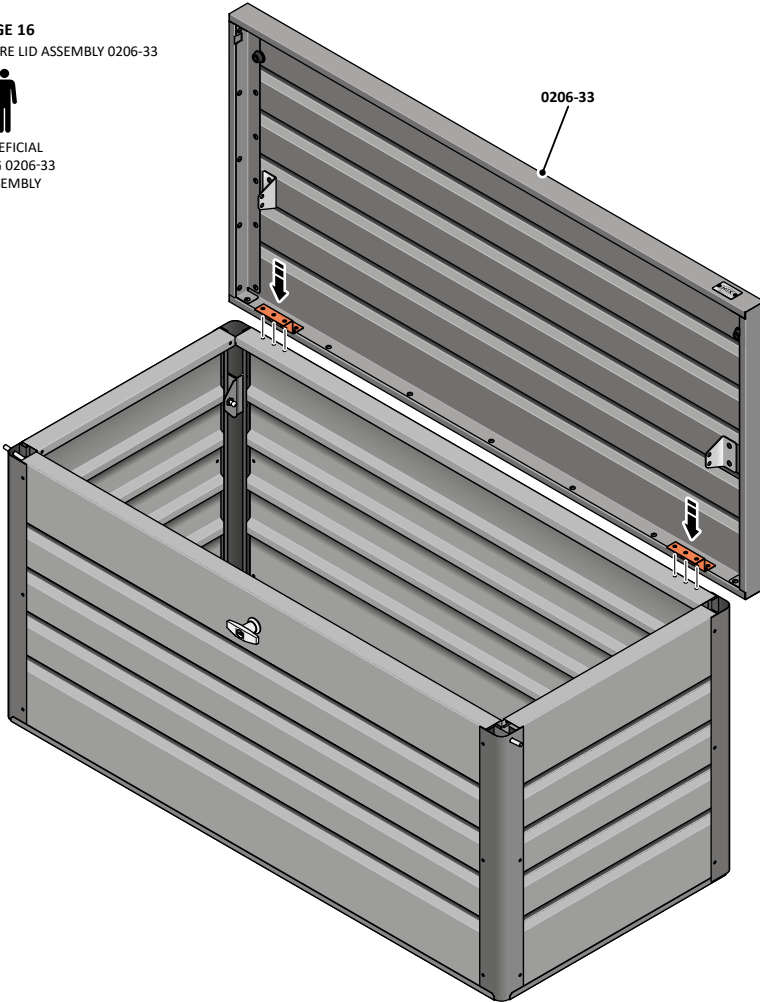

SECURE LID ASSEMBLY HINGE ONTO REAR PANEL AT EACH LOCATION INDICATED.

ASSEMBLY STAGE 17

SECURE BALL STUDS 0205-68 ONTO LID ASSEMBLY

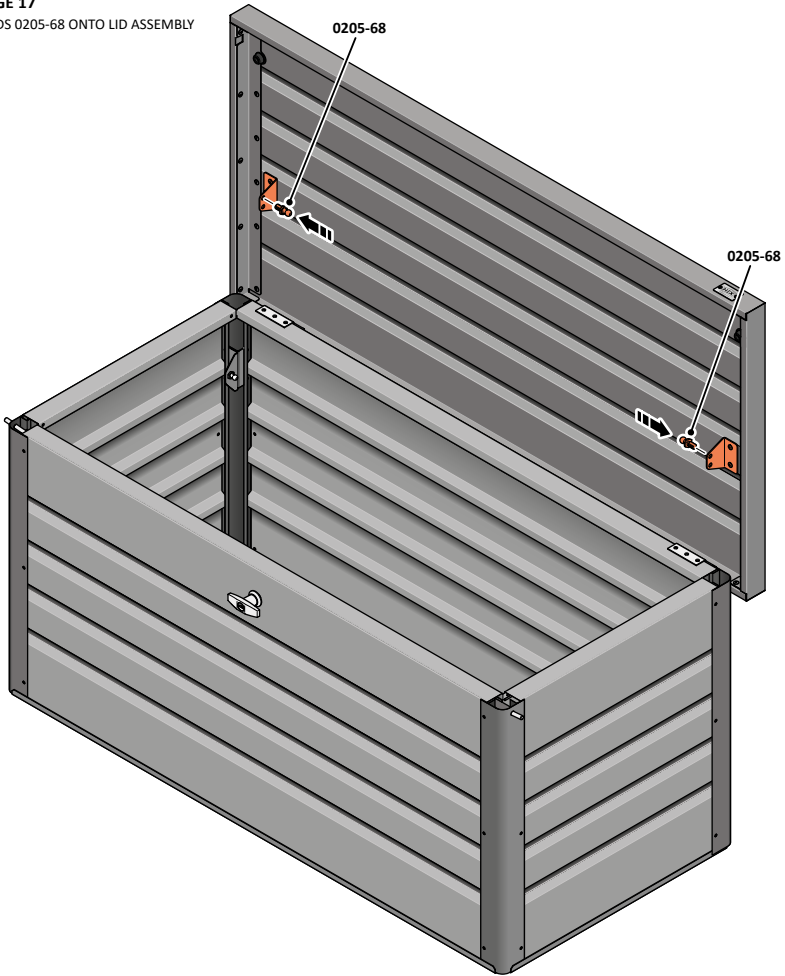

17A

SECURE BALL STUD 0205-68 ONTO LID ASSEMBLY AS SHOWN.

⚠ ENSURE UPPER FIXING HOLE IS USED.



17B

SECURE BALL STUD 0205-68 ONTO LID ASSEMBLY AS SHOWN.

⚠ ENSURE UPPER FIXING HOLE IS USED.

ASSEMBLY STAGE 18

LOCATE AND ATTACH GAS STRUTS 0206-18.

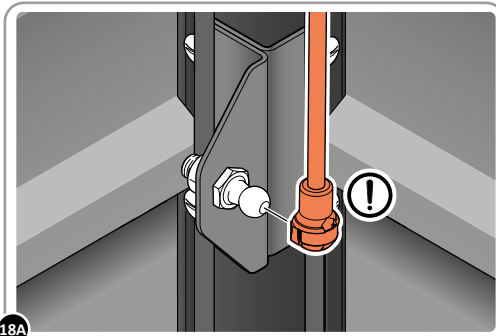
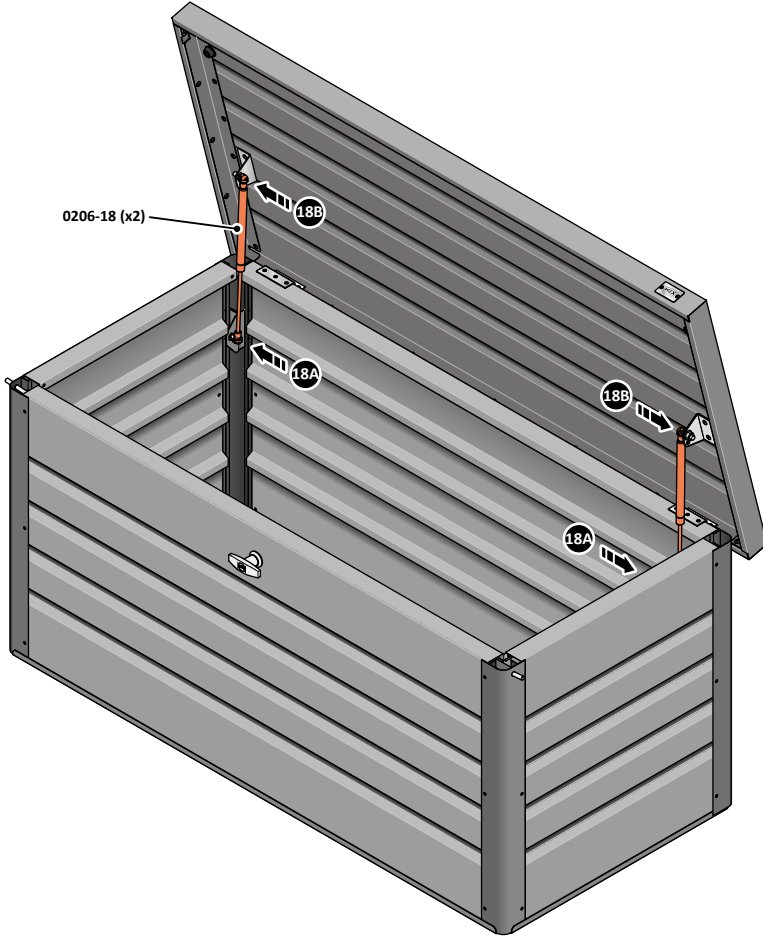

18A

LOCATE AND ATTACH GAS STRUT 0206-18 ONTO BALL JOINTS AS SHOWN.

⚠ ENSURE GAS STRUT IS ATTACHED IN THE ORIENTATION SHOWN.

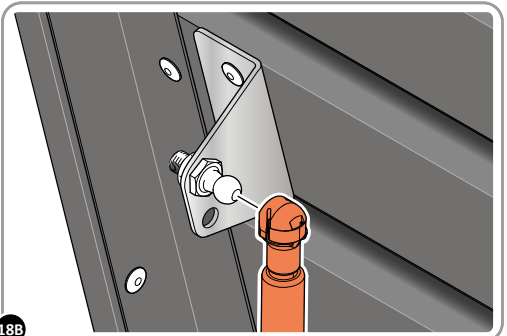

18B

ATTACH REMAINING ELEMENT OF GAS STRUT ONTO BALL JOINTS AS SHOWN.

ASSEMBLY STAGE 19

LOCATE AND INSERT END CAPS 0204-30.

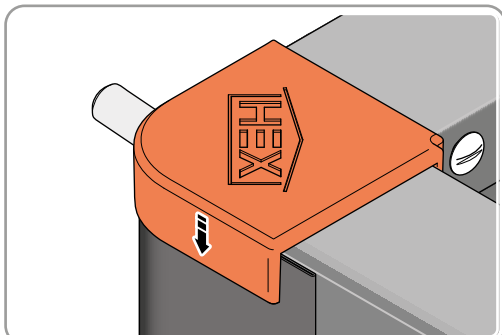
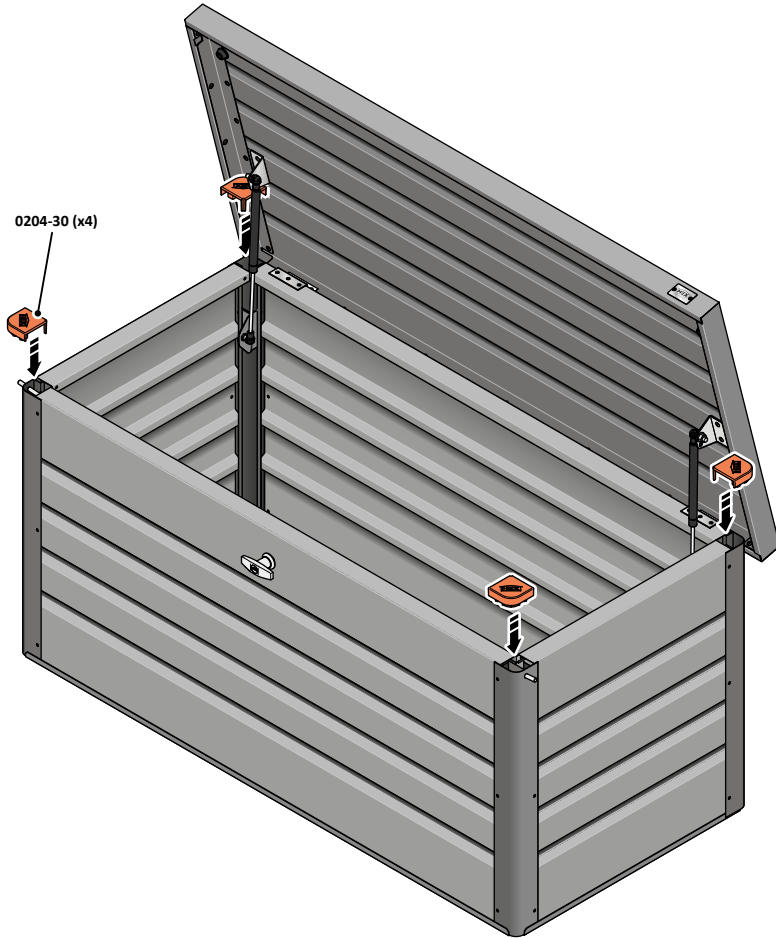

LOCATE AND INSERT END CAPS 0204-30 AT EACH CORNER POST AS SHOWN.



IMPORTANT

ADJUST ALL COMPONENTS FOR BEST POSSIBLE
FIT AND TIGHTEN ALL FASTENERS.
ONCE ALL FASTENERS HAVE BEEN CHECKED AND ARE
SECURE THE ASSEMBLY IS COMPLETE.

Caring for your HEX Living product

Your HEX Living product is designed to stand the test of time, which is why we're happy to offer a lifetime warranty on our products. With zero maintenance required, simply assemble your HEX Living product, and enjoy putting it to great use in your garden.

Periodically, you might want to give your product a clean, these simple care tips are not essential to the performance of your product:

- Remove surface dirt with plain water using a jet wash or sponge, the coating on our products will ensure dirt or mud simply wipes away.
- If you've purchased a HEX Living metal storage solution, periodically clear the roof of fallen leaves.
- If your product has guttering, remove leaves and garden debris as you would on your home.

Ensure you have registered your HEX Living product

Using the unique serial number found on the cover of this document, please visit www.hexliving.co.uk to register your product and access the HEX Living lifetime warranty and video instructions.

