

10 x 6 Large Metal Storage Shed

Flooring Kit Assembly Guide

Assembly Guide - 10 x 6

PARTS LIST

WOODEN FLOOR KIT

0212-GREY-FW
0225-GREEN-FW

Part Ref: 0205-11
Qty: x1

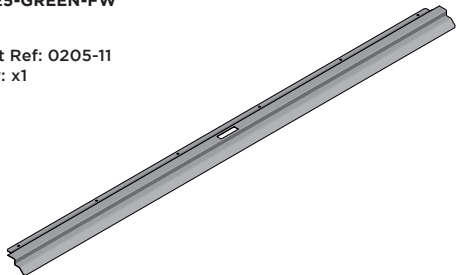

Part Ref: 0212-08
Qty: x4

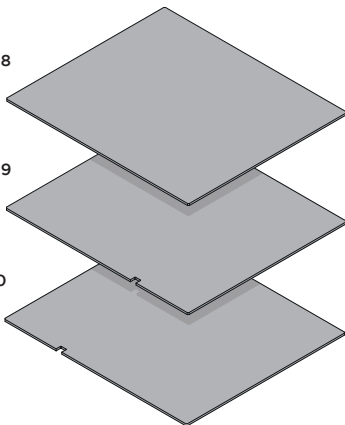

Part Ref: 0212-09
Qty: x1

Part Ref: 0212-10
Qty: x1

ALUMINIUM FLOOR KIT

0212-GREY-FM
0225-GREEN-FM

Part Ref: 0205-73
Qty: x1

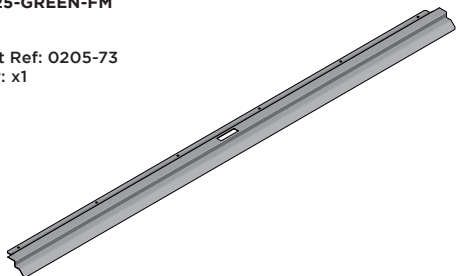

Part Ref: 0212-18
Qty: x4

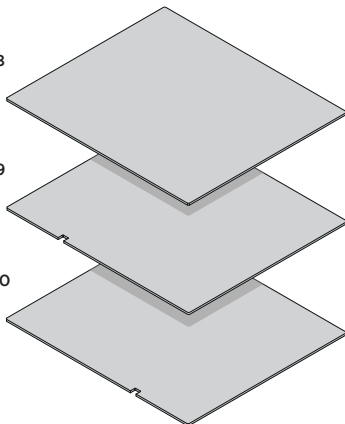

Part Ref: 0212-19
Qty: x1

Part Ref: 0212-20
Qty: x1

Part Ref: 0212-02
Qty: x5

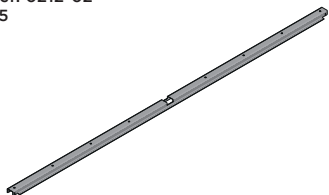

Part Ref: 0205-04
Qty: x2

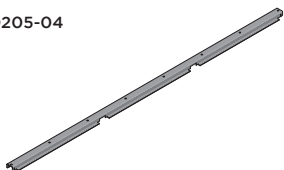

NEW ASSEMBLY KIT: 0205-71

Part Ref: FK1
3.9 x 22mm Self Drilling Screw
Qty: x26



Part Ref: FK2
No.8 x 13mm Eco Fix
Qty: x7



ORIGINAL ASSEMBLY KIT

Part Ref: FK1
M4 x 10mm Roofing Bolt
Qty: x2



Part Ref: FK7
M4 Serrated Flange Nut
Qty: x2



Assembly Guide - 10 x 6

ASSEMBLY STAGE 1

LOCATE AND REMOVE DOOR STRIP 0205-74

IMPORTANT: STAGE 1 IS ONLY RELEVANT IF YOU HAVE PURCHASED A NEW FLOORING KIT, AFTER THE SHED HAS BEEN FULLY ASSEMBLED.

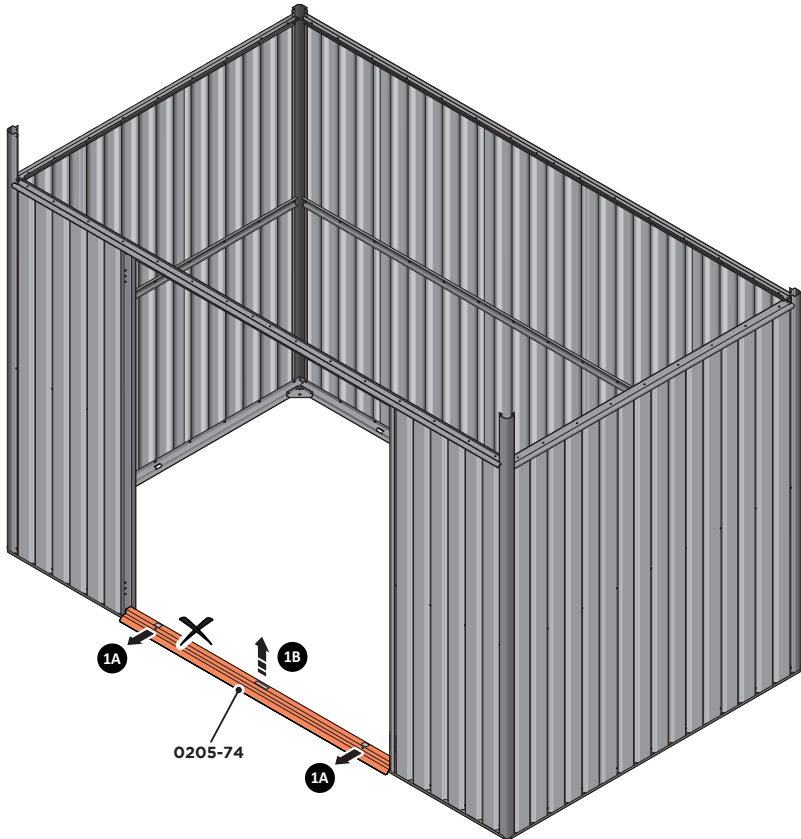

IMPORTANT: IF THE FLOORING KIT CAME SUPPLIED WITH THIS PRODUCT, PLEASE IGNORE ASSEMBLY STAGE 1 AND MOVE ONTO STAGE 2 INSTRUCTIONS.

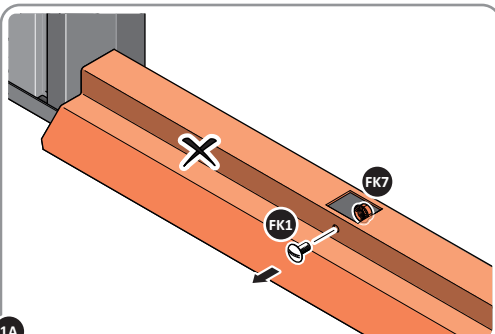

1A REMOVE NUT AND BOLT FROM DOOR STRIP AT x2 LOCATIONS INDICATED.

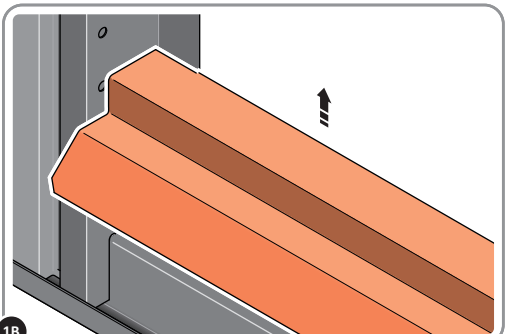

1B REMOVE DOOR STRIP 0205-74 FROM FLOOR PANELS AS SHOWN.

Assembly Guide - 10 x 6

ASSEMBLY STAGE 2

LOCATE AND SECURE A FLOOR BRACE 0212-02 AT EACH LOCATION INDICATED.

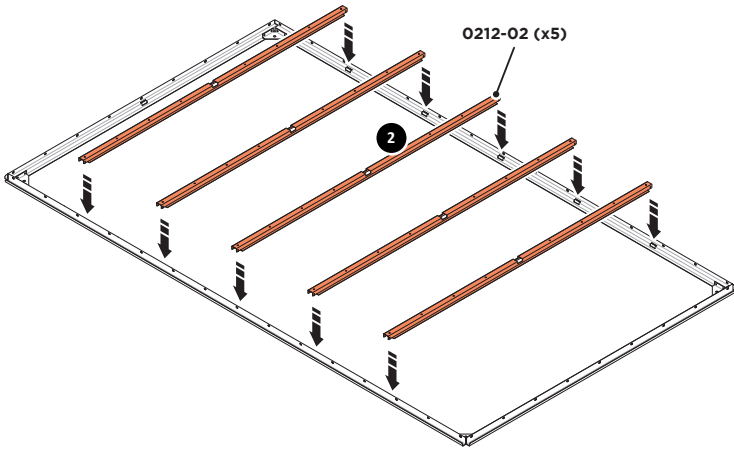

ASSEMBLY STAGE 3

LOCATE AND SECURE A FLOOR BRACE 0205-04 AT EACH LOCATION INDICATED.

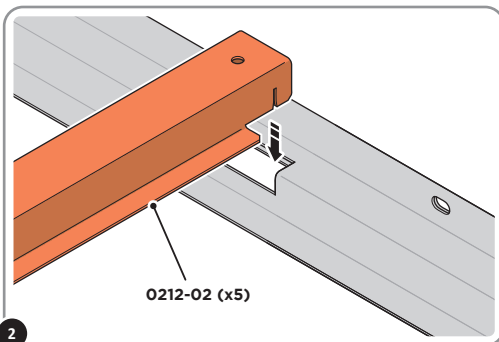
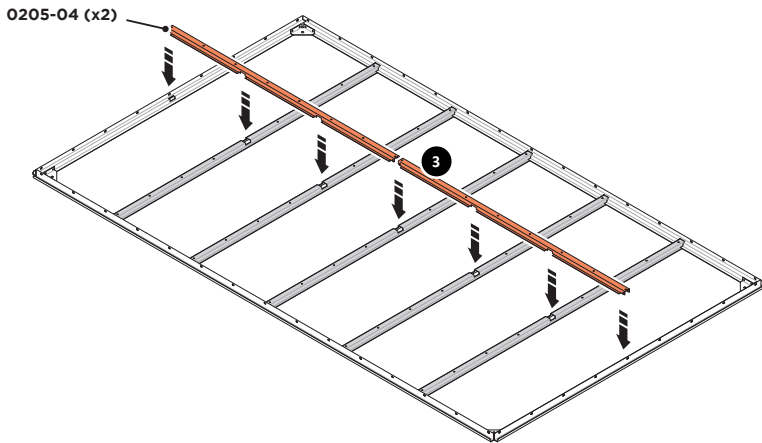

2 SLOT EACH FLOOR BRACE 0212-02 INTO POSITION AS SHOWN ABOVE.

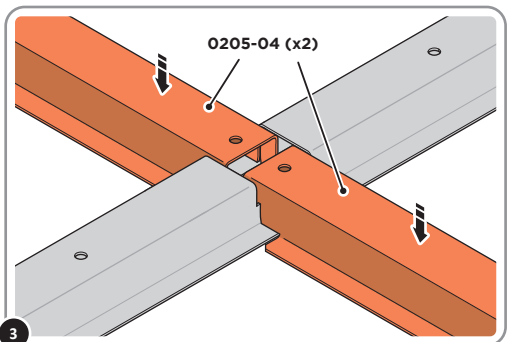

3 SLOT EACH FLOOR BRACE 0205-04 INTO POSITION AS SHOWN ABOVE. PLEASE NOTE: ENSURE TOP OF FLOOR BRACE IS LEVEL WITH TOP OF FLOOR RAIL.

Assembly Guide - 10 x 6

ASSEMBLY STAGE 4

LOCATE FLOOR PANELS 0212-08 OR 0212-18.

SLOT FIRST THREE FLOOR PANELS 0212-08 OR 0212-18 INTO THE BACK HALF OF FLOOR FRAME.

IMPORTANT: THESE FLOOR PANELS DO NOT HAVE A CUT-OUT. ENSURE THE PATTERN FLOORING IS FACE UP.

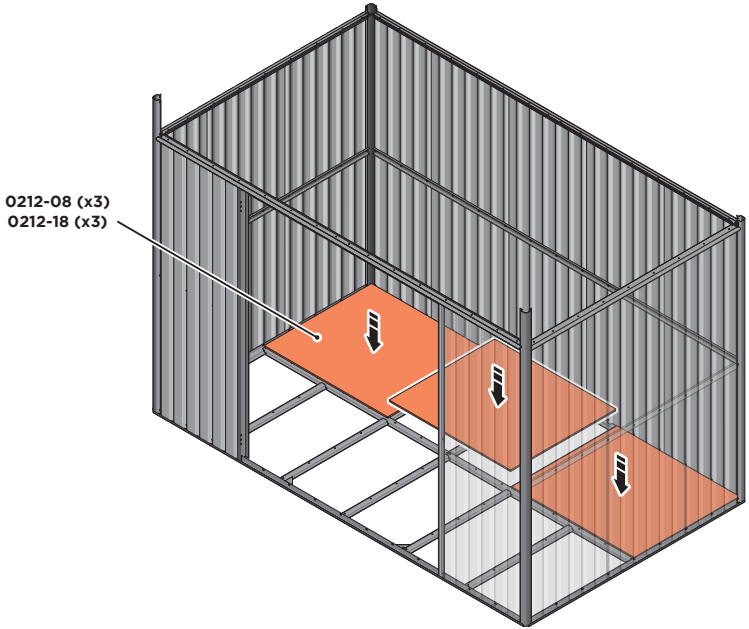

ASSEMBLY STAGE 5

LOCATE FLOOR PANELS 0212-08 OR 0212-18, 0212-09 OR 0212-20 AND 0212-10 OR 0212-19.

SLOT LEFT AND RIGHT-HAND FLOOR PANELS AND THEN MIDDLE FLOOR PANEL, INTO THE FRONT HALF OF FLOOR FRAME.

ENSURE THE PATTERN FLOORING IS FACE UP.

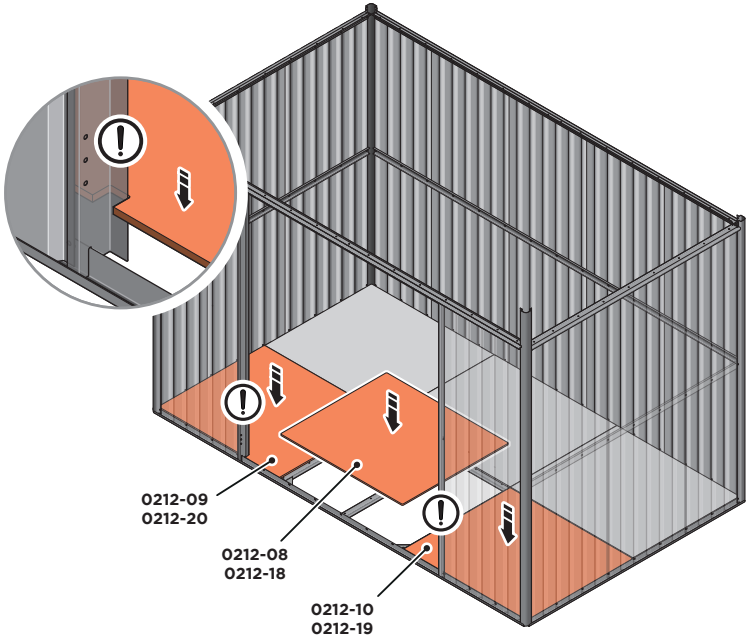

Assembly Guide - 10 x 6

ASSEMBLY STAGE 6

LOCATE AND SECURE DOOR STRIP 0205-11 OR 0205-73.

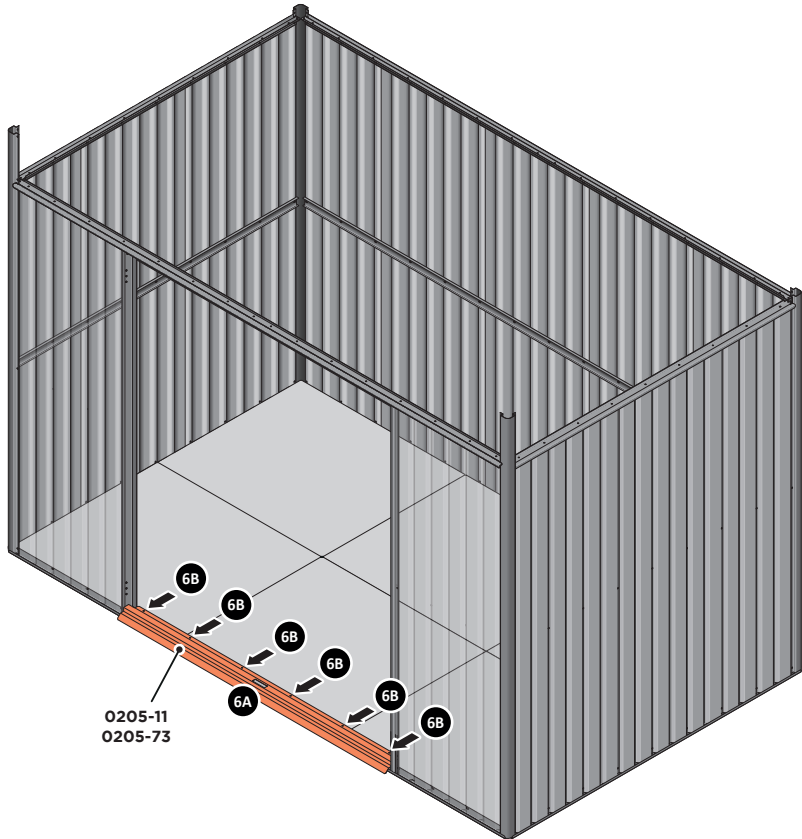

IMPORTANT: ONCE FLOOR PANELS ARE POSITIONED CORRECTLY, WE STRONGLY RECOMMEND YOU SECURE THE FLOORING TO THE BASE. FOLLOWING INSTRUCTIONS ON PAGE 7.

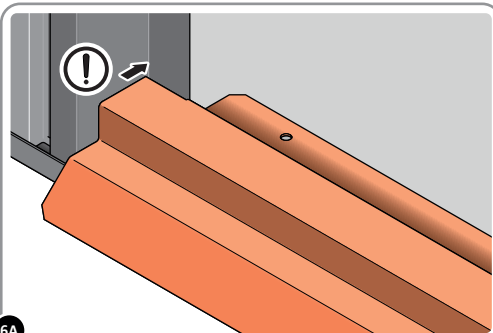

6A

LOCATE DOOR STRIP 0205-11 OR 0205-73 AS SHOWN.
IMPORTANT: ENSURE DOOR STRIP IS PUSHED AGAINST DOOR POST RETURN.

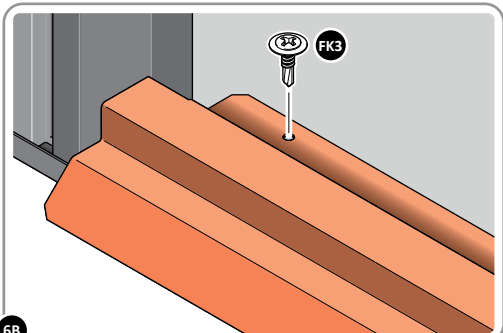

6B

SECURE DOOR STRIP ONTO FLOOR PANELS AT x6 LOCATION INDICATED.
PLEASE NOTE: THE FIXING USED IS A SELF DRILLING COMPONENT.

Securing Flooring to Base Cutout Template

ASSEMBLY STAGE 7

LOCATE AND SECURE FLOOR PANELS TO SHED BASE

TOOLS NEEDED



SINGLE PERSON ASSEMBLY

MOST PROCEDURES WILL NOT REQUIRE TWO PEOPLE BUT IT MAY BE EASIER TO HAVE ASSISTANCE.



PERSONAL PROTECTION EQUIPMENT

WE ADVISE APPROPRIATE PERSONAL PROTECTIVE EQUIPMENT IS WORN DURING ASSEMBLY INCLUDING EYE PROTECTION AND GLOVES.



TYPICAL SIX PIECE FLOORING WITH SUGGESTED SCREW LOCATIONS (20), MEASUREMENTS IN (MM)

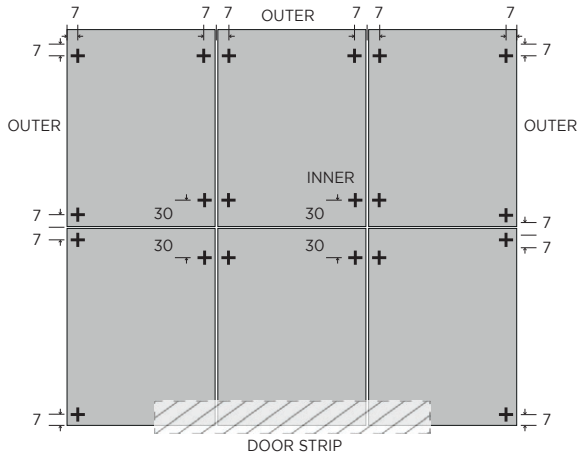

ASSEMBLY STAGE 7A

MARK OUT FIXING SCREWS LOCATIONS

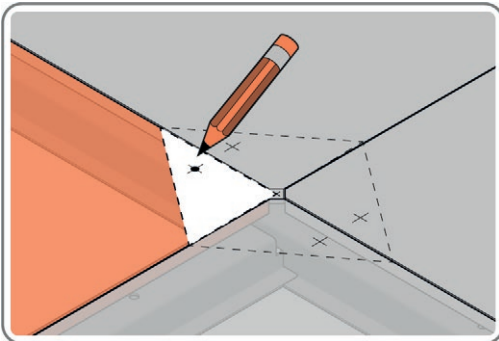

USE TEMPLATE BELOW TO MARK OUT SUGGESTED LOCATIONS FOR SECURING FLOOR TO BASE. (NOTE: ONLY MARK INNER CORNER PANELS - 7 x 30 mm).

ASSEMBLY STAGE 7B

LOCATE FIXING SCREW AND DRILL TO FLOOR

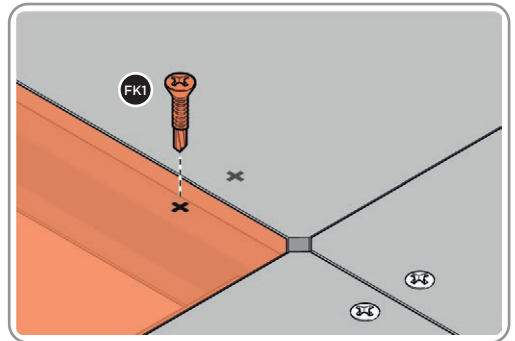

USE DRILL TO SECURE FIXING SCREW FK1 TO EACH FLOOR PANEL MARKED.

CUT OUT TEMPLATE GUIDE BELOW

SHOWING SUGGESTED LOCATION HOLES FOR FIXING SCREWS (FK1), FOR DRILLING INTO FLOORING AND BASE.

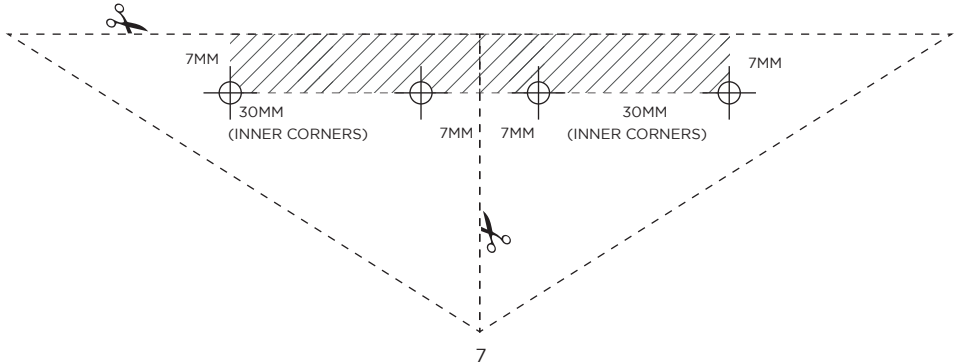

Ensure you have registered your product

If you require any assistance
our telephone lines are open:

Mon - Fri, 8am - 5pm

+44 (0) 1889 272 056