

# **6 x 6 Large Metal Storage Shed**

**Flooring Kit Assembly Guide**

# Assembly Guide - 6 x 6

## PARTS LIST

### WOODEN FLOOR KIT

0215-GREY-FW  
0228-GREEN-FW

Part Ref: 0205-11  
Qty: x1

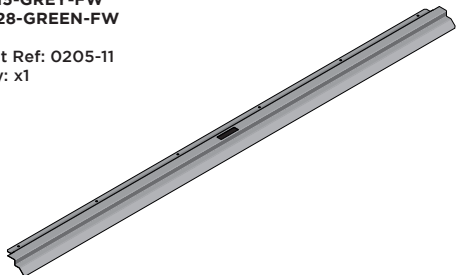

Part Ref: 0215-09  
Qty: x2

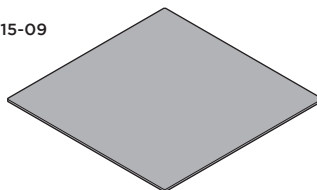

Part Ref: 0215-10  
Qty: x2

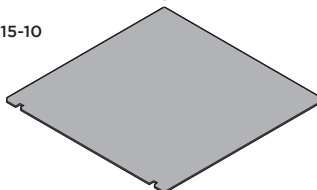

### ALUMINIUM FLOOR KIT

0215-GREY-FM  
0228-GREEN-FM

Part Ref: 0205-73  
Qty: x1

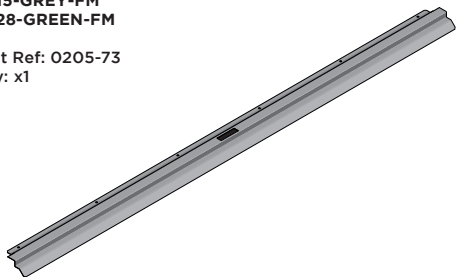

Part Ref: 0215-17  
Qty: x2

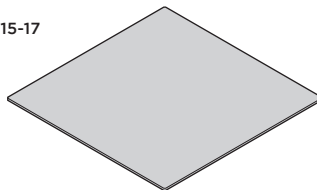

Part Ref: 0215-18  
Qty: x2

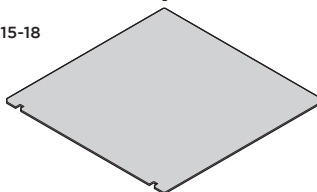

Part Ref: 0212-02  
Qty: x3

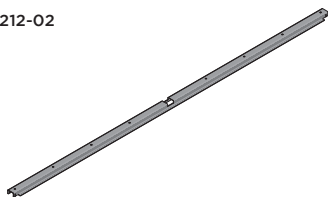

### NEW ASSEMBLY KIT: 0205-71

Part Ref: FK1  
3.9 x 22mm Self Drilling Screw  
Qty: x26



Part Ref: FK2  
No.8 x 13mm Eco Fix  
Qty: x7



Part Ref: 0215-08  
Qty: x2

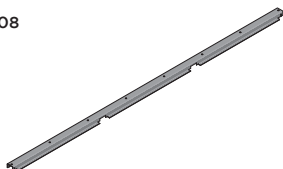

### ORIGINAL ASSEMBLY KIT

Part Ref: FK1  
M4 x 10mm Roofing Bolt  
Qty: x2



Part Ref: FK7  
M4 Serrated Flange Nut  
Qty: x2



# Assembly Guide - 6 x 6

## ASSEMBLY STAGE 1

LOCATE AND REMOVE DOOR STRIP 0205-74

**IMPORTANT:** STAGE 1 IS ONLY RELEVANT IF YOU HAVE PURCHASED A NEW FLOORING KIT, AFTER THE SHED HAS BEEN FULLY ASSEMBLED.

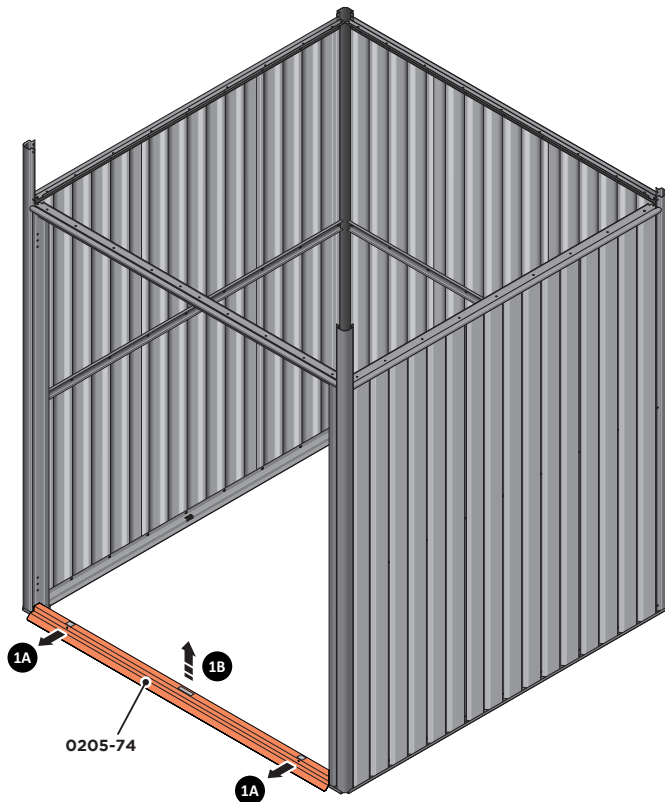

**IMPORTANT:** IF THE FLOORING KIT CAME SUPPLIED WITH THIS PRODUCT, PLEASE IGNORE ASSEMBLY STAGE 1 AND MOVE ONTO STAGE 2 INSTRUCTIONS.

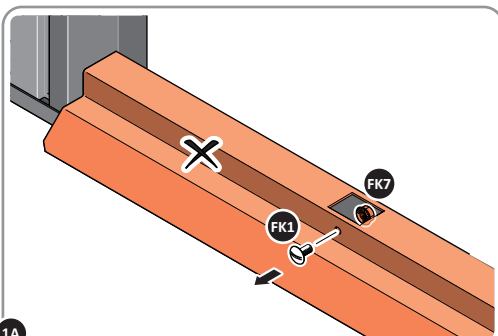

**1A** REMOVE NUT AND BOLT FROM DOOR STRIP AT x2 LOCATIONS INDICATED.

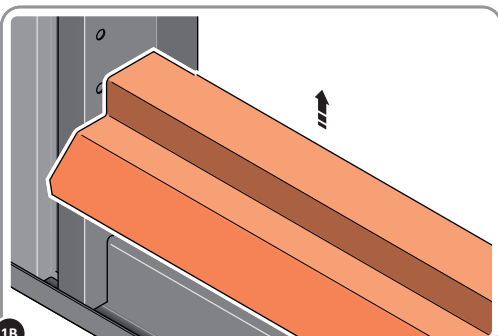

**1B** REMOVE DOOR STRIP 0205-74 FROM FLOOR PANELS AS SHOWN.

# Assembly Guide - 6 x 6

## ASSEMBLY STAGE 2

LOCATE AND SECURE A FLOOR BRACE 0212-02 AT EACH LOCATION INDICATED.

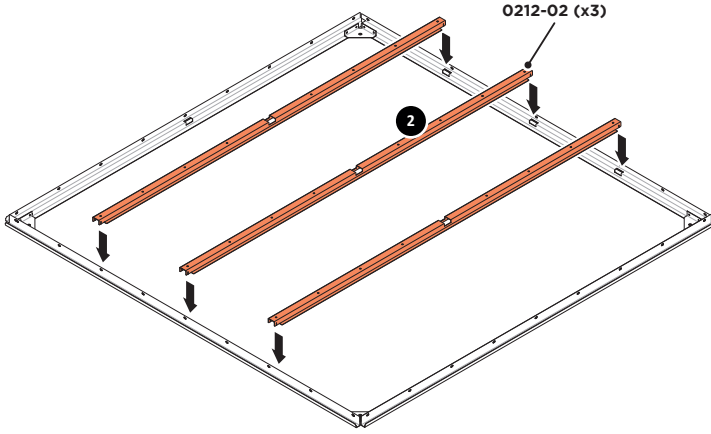

## ASSEMBLY STAGE 3

LOCATE AND SECURE A FLOOR BRACE 0215-08 AT EACH LOCATION INDICATED.

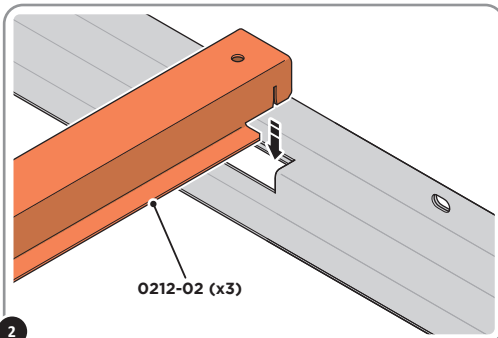
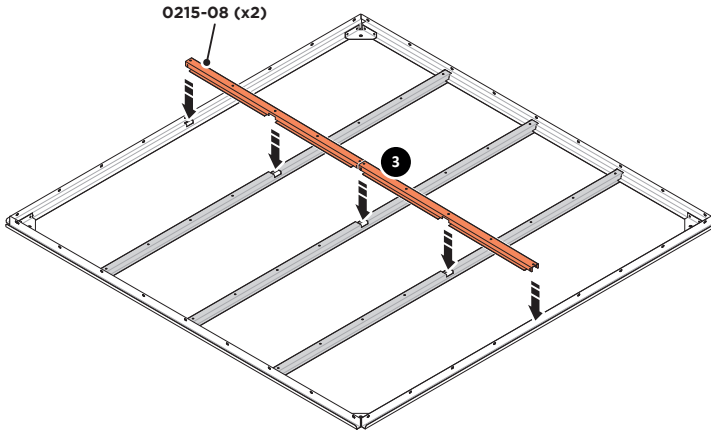

SLOT EACH FLOOR BRACE 0212-02 INTO POSITION AS SHOWN ABOVE.

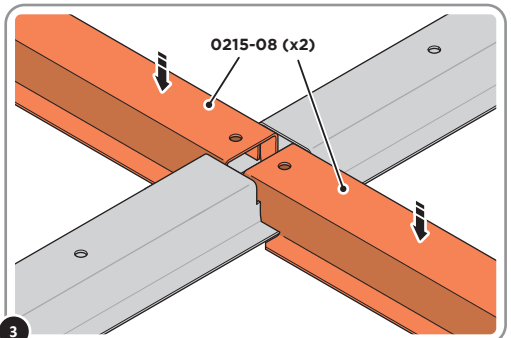

SLOT EACH FLOOR BRACE 0215-08 INTO POSITION AS SHOWN ABOVE. PLEASE NOTE: ENSURE TOP OF FLOOR BRACE IS LEVEL WITH TOP OF FLOOR RAIL

# Assembly Guide - 6 x 6

## ASSEMBLY STAGE 4

LOCATE FLOOR PANELS 0215-09 OR 0215-17.

SLOT FIRST TWO FLOOR PANELS 0215-09 OR 0215-17 INTO THE BACK HALF OF FLOOR FRAME.

**IMPORTANT:** THESE FLOOR PANELS DO NOT HAVE A CUT-OUT. ENSURE THE PATTERN FLOORING IS FACE UP.

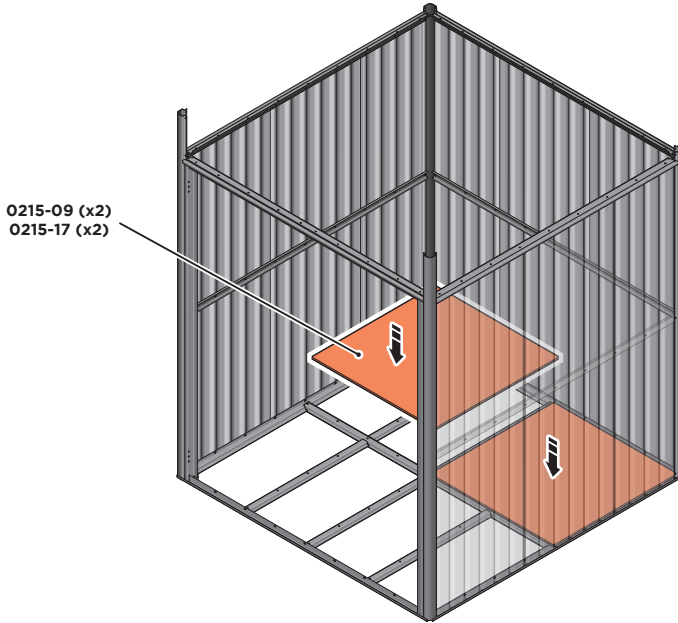

## ASSEMBLY STAGE 5

LOCATE FLOOR PANELS 0215-10 OR 0215-18.

SLOT FLOOR PANELS 0215-10 OR 0215-18, INTO THE FRONT HALF OF FLOOR FRAME. ENSURE THE PATTERN FLOORING IS FACE UP.

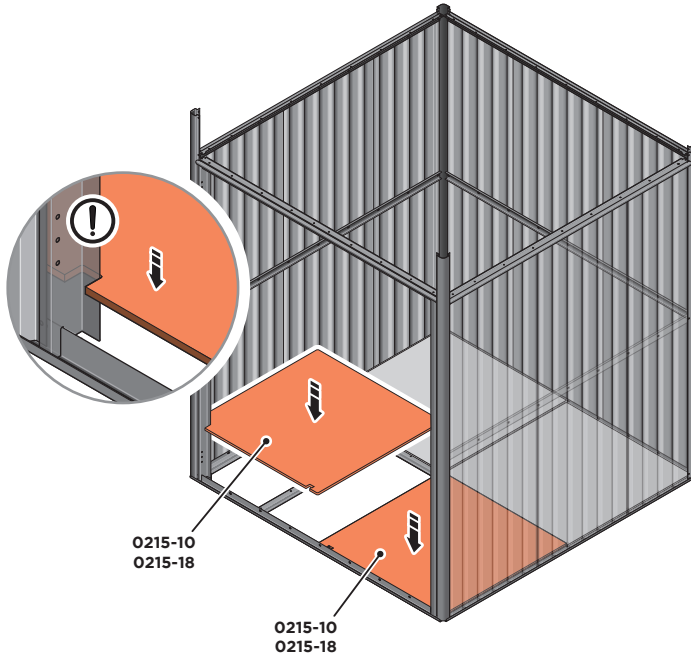

# Assembly Guide - 6 x 6

## ASSEMBLY STAGE 6

LOCATE AND SECURE DOOR STRIP 0205-11 OR 0205-73.

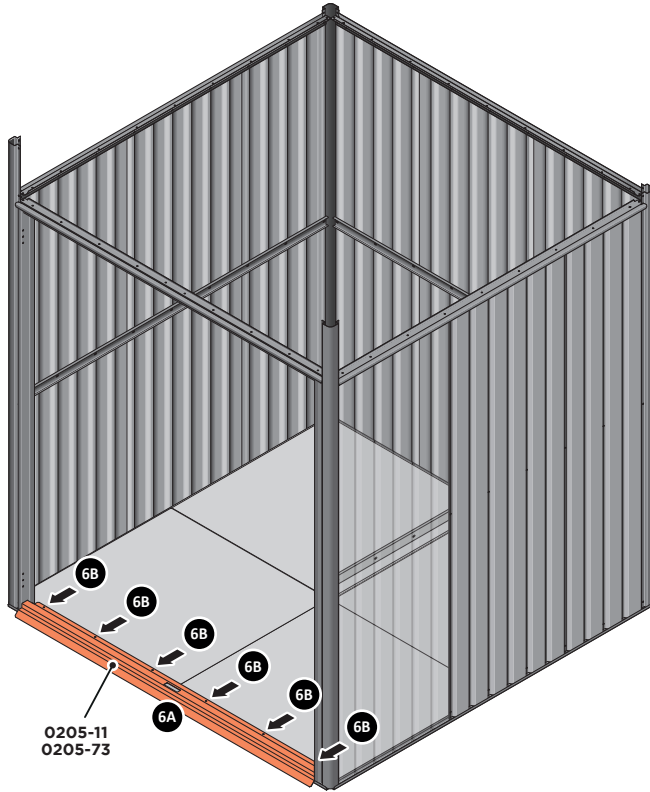

**IMPORTANT:** ONCE FLOOR PANELS ARE POSITIONED CORRECTLY, WE STRONGLY RECOMMEND YOU SECURE THE FLOORING TO THE BASE. FOLLOWING INSTRUCTIONS ON PAGE 7.

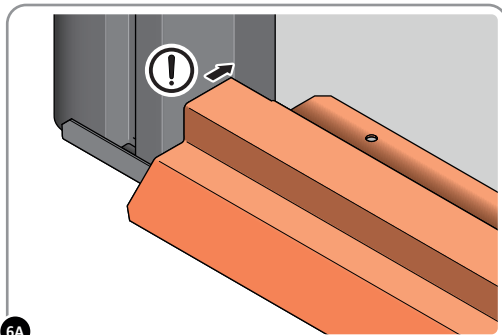

6A

LOCATE DOOR STRIP 0205-11 OR 0205-73 AS SHOWN.  
**IMPORTANT:** ENSURE DOOR STRIP IS PUSHED AGAINST DOOR POST RETURN.

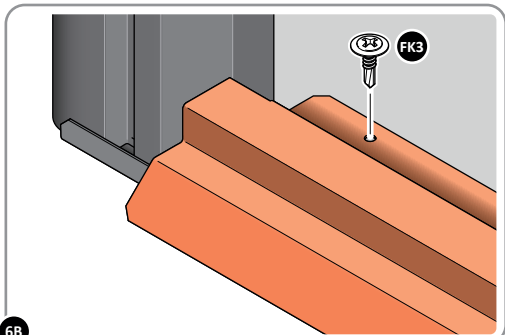

6B

SECURE DOOR STRIP ONTO FLOOR PANELS AT x6 LOCATION INDICATED.  
PLEASE NOTE: THE FIXING USED IS A SELF DRILLING COMPONENT.

# Securing Flooring to Base Cutout Template

## ASSEMBLY STAGE 7

LOCATE AND SECURE FLOOR PANELS TO SHED BASE

### TOOLS NEEDED



DRILL WITH PHILLIPS HEAD BIT.



MARKER.

### SINGLE PERSON ASSEMBLY

MOST PROCEDURES WILL NOT REQUIRE TWO PEOPLE BUT IT MAY BE EASIER TO HAVE ASSISTANCE.



### PERSONAL PROTECTION EQUIPMENT

WE ADVISE APPROPRIATE PERSONAL PROTECTIVE EQUIPMENT IS WORN DURING ASSEMBLY INCLUDING EYE PROTECTION AND GLOVES.



### TYPICAL 4 PIECE FLOORING WITH SUGGESTED SCREW LOCATIONS, (14) MEASUREMENTS IN (MM)

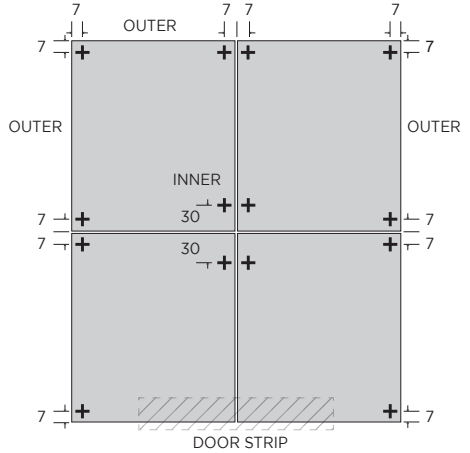

## ASSEMBLY STAGE 7A

MARK OUT FIXING SCREWS LOCATIONS

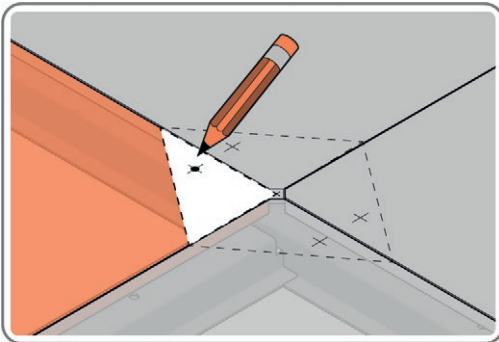

USE TEMPLATE BELOW TO MARK OUT SUGGESTED LOCATIONS FOR SECURING FLOOR TO BASE. (NOTE: ONLY MARK INNER CORNER PANELS - 7 x 30 mm).

## ASSEMBLY STAGE 7B

LOCATE FIXING SCREW AND DRILL TO FLOOR

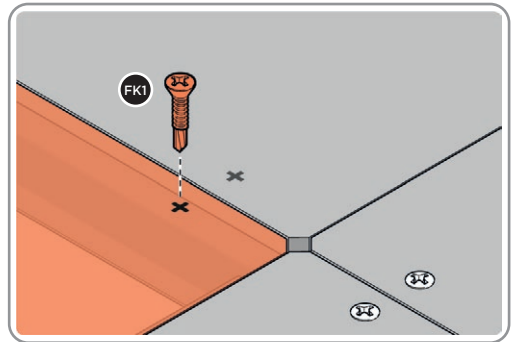

USE DRILL TO SECURE FIXING SCREW FK1 TO EACH FLOOR PANEL MARKED.

## CUT OUT TEMPLATE GUIDE BELOW

SHOWING SUGGESTED LOCATION HOLES FOR FIXING SCREWS (FK1), FOR DRILLING INTO FLOORING AND BASE.

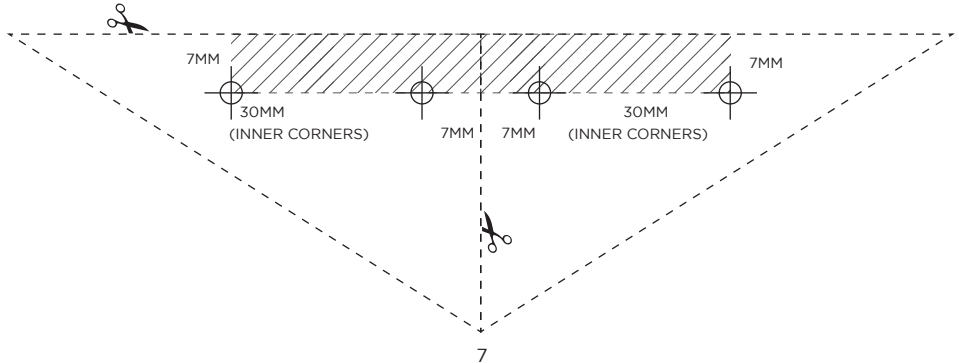

## **Ensure you have registered your product**

If you require any assistance  
our telephone lines are open:

Mon - Fri, 8am - 5pm

**+44 (0) 1889 272 056**