

Farley

1200L Metal Storage Box Guide

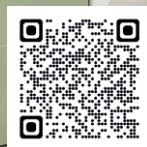

IMPORTANT: PLEASE REGISTER YOUR HEX LIVING PRODUCT AFTER ASSEMBLY

Using the unique serial number, simply register your product at www.hexliving.co.uk or use the QR code above to access the HEX Living lifetime warranty and online support.

Affix Serial Number
HERE



PLEASE READ THIS DOCUMENT FULLY PRIOR TO STARTING ASSEMBLY PROCEDURE

The objective of this instruction is to illustrate the recommended assembly sequence for this product, any deviation from this will be the sole responsibility of whoever carries out the assembly.

IMPORTANT: IT IS ADVISABLE THAT THE PRODUCT IS ASSEMBLED AT, OR AS CLOSE AS POSSIBLE TO WHERE IT WILL BE FINALLY LOCATED

- Do not install damaged parts. Please report any defects to our customer service team on +44 (0) 1889 272056
- Do not assemble in windy conditions.
- Keep all supplied small parts or packaging materials away from small children and pets during assembly.
- Ensure there is adequate clearance where the product is to be located:

Exterior dimensions including overhang (W x D x H)	1610 x 860 x 920mm
Footprint dimensions (W x D)	1600 x 860mm
Clearance required for lid to open (W x H)	Lid open outwards 1600 x 1710mm

TWO PERSON ASSEMBLY

Most procedures will not require two people but it may be easier to have assistance.



PERSONAL PROTECTION EQUIPMENT

We advise appropriate personal protective equipment is worn during assembly including eye protection and gloves.



CARING FOR YOUR HEX LIVING PRODUCT

Your **HEX Living** product is designed to stand the test of time, which is why we're happy to offer a lifetime warranty on our products. With zero maintenance required, simply assemble your HEX Living product and enjoy putting it to great use in your garden.

Periodically, you might want to give your product a clean, these simple care tips are not essential to the performance of your product:

- Remove surface dirt with plain water using a jet wash or sponge, the coating on our products will ensure dirt or mud simply wipes away.
- Periodically clear the lid of fallen leaves.
- NOTE: during the summer months, high temperature might arise in the interior.
- To prevent damage in wet and windy weather conditions, make sure the product is secured in a storm-proof manner and the lid is locked.

PRODUCT REGISTRATION

IMPORTANT: Please ensure you have registered your HEX Living product using the unique serial number found on the cover of this document, please visit www.hexliving.co.uk to register your product and access the HEX Living lifetime warranty and support.

Assembly Guide

ENSURE ALL ITEMS LISTED ARE PRESENT PRIOR TO STARTING ASSEMBLY PROCEDURE

SCALE OF ITEMS WILL VARY TO AID VISUAL IDENTIFICATION

Part Ref: 0249-01
Qty: x2

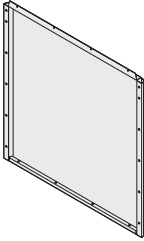

Part Ref: 0249-02
Qty: x1

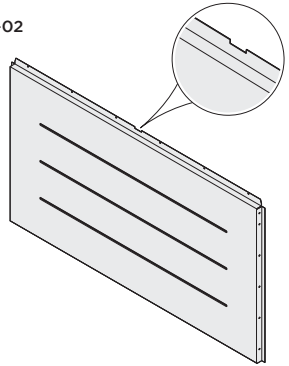

Part Ref: 0249-22
Qty: x1

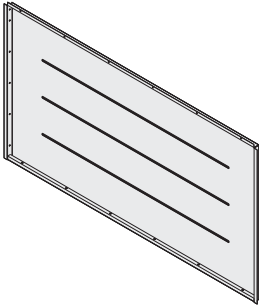

Part Ref: 0249-03
Qty: x1

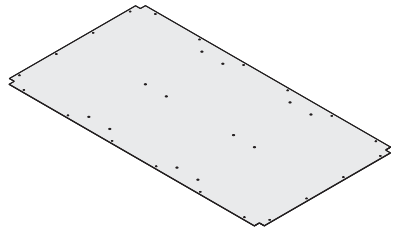

Part Ref: 0249-04
Qty: x1

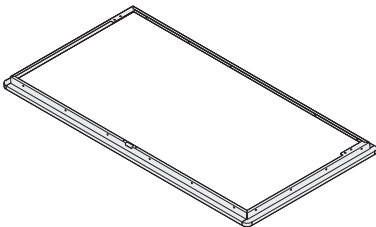

Part Ref: 0249-05
Qty: x1

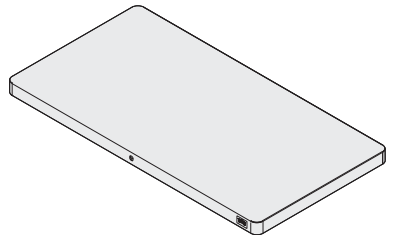

Assembly Guide

ENSURE ALL ITEMS LISTED ARE PRESENT PRIOR TO STARTING ASSEMBLY PROCEDURE

SCALE OF ITEMS WILL VARY TO AID VISUAL IDENTIFICATION

Part Ref: 0249-10
Qty: x1

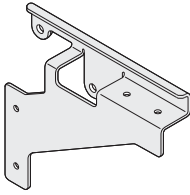

Part Ref: 0249-11
Qty: x1

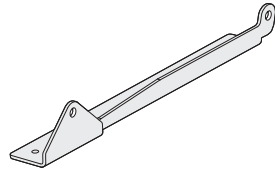

Part Ref: 0249-12
Qty: x1

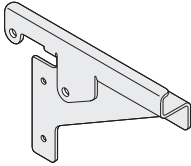

Part Ref: 0249-09
Qty: x1

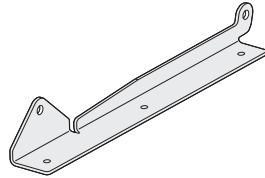

Part Ref: 0249-26
Qty: x2

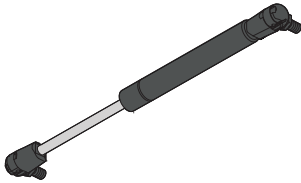

Part Ref: 0249-16
Qty: x4

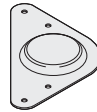

Part Ref: 0249-19
Qty: x1

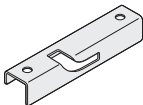

Part Ref: 0249-23
Qty: x1

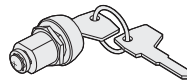

THIS PART IS NOT REQUIRED



Assembly Guide

ENSURE ALL ITEMS LISTED ARE PRESENT PRIOR TO STARTING ASSEMBLY PROCEDURE

SCALE OF ITEMS WILL VARY TO AID VISUAL IDENTIFICATION

Part Ref: 0249-24

Qty: x1

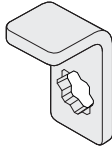

Part Ref: 0249-25

Qty: x1

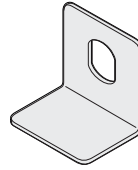

Part Ref: 0204-66

Qty: x2



Part Ref: 0249-05-03

Qty: x2



1200L FIXING KIT: 0249-27

Part Ref: 0249-27-01
No.5 x 12mm Pan Head Pozi
Qty: x52

FK1



Part Ref: 313-0009Z
No.8 x 13mm Eco Fix
Qty: x18

FK6



Part Ref: 0262-16
M8 x 20mm Button Head Screw
Qty: x2

FK2



Part Ref: 0203-54
M8 Serrated Flange Nut
Qty: x4

FK7



Part Ref: 0262-17
8.3mm Nylon Washer
Qty: x2

FK3



Part Ref: 0203-52
M4 x 10mm Roofing Bolt
Qty: x23

FK8



Part Ref: 0262-18
M8 Nyloc Nut
Qty: x2

FK4



Part Ref: 0203-55
M4 Serrated Flange Nut
Qty: x28

FK9



Part Ref: 0262-19
M4 x 25mm Cap Screw
Qty: x2

FK5



Assembly Guide

ASSEMBLY STAGE 1

LOCATE AND LOOSELY ATTACH SIDE PANELS 0249-01 TO BACK PANEL 0249-22.

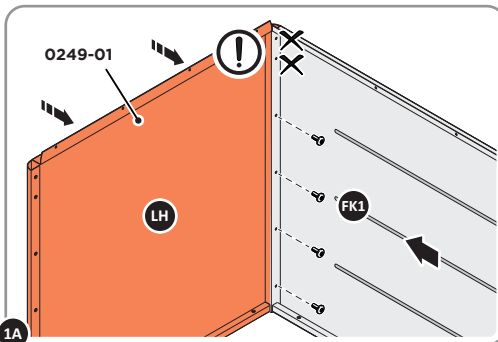
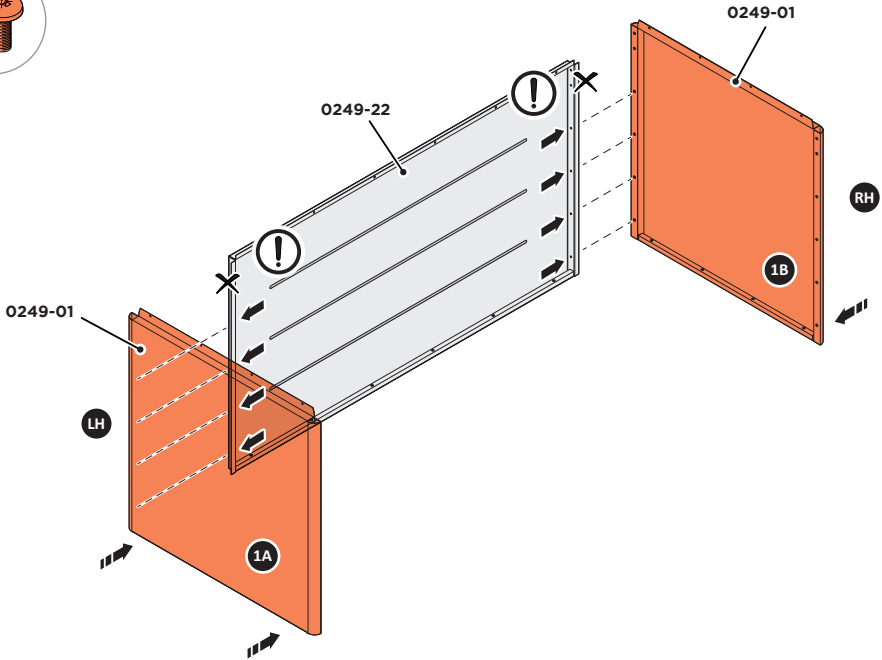

LOCATE AND LOOSELY SECURE END PANELS TO BACK PANEL.
IMPORTANT: ONLY SECURE (x4) FIXING POINTS INDICATED AT THIS STAGE.

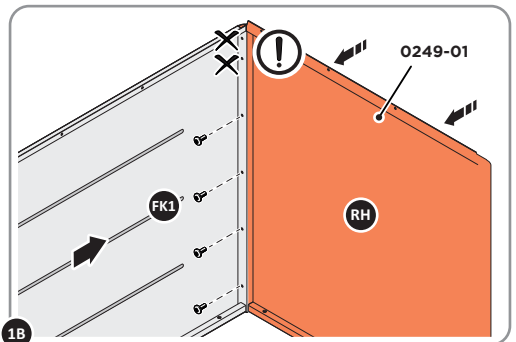

NOTE: IGNORE THE TOP TWO HOLES, THESE ARE NEEDED FOR STAGE 10.

Assembly Guide

ASSEMBLY STAGE 2

LOCATE AND LOOSELY ATTACH FLOOR PANEL 0249-03 TO BACK PANEL 0249-22.

NOTE: TO AVOID DAMAGE TO THE PAINTED FINISH, WE RECOMMEND PLACING THE PRODUCT ON A SCRATCH-RESISTANT SURFACE.

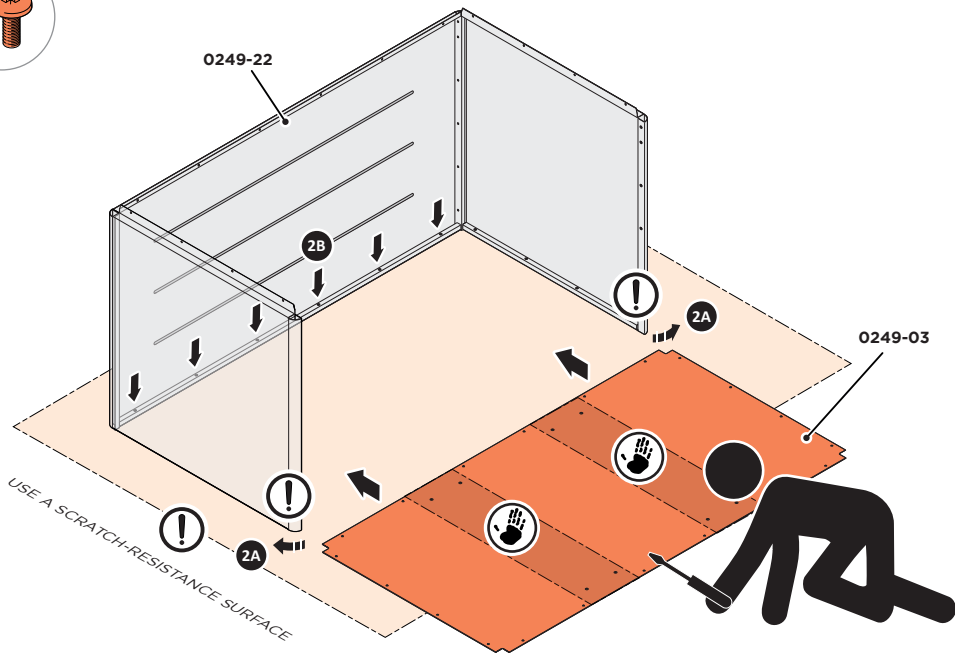

NOTE: THE HIGHLIGHTED AREAS ARE REINFORCED TO PROVIDE EXTRA STRENGTH AND SUPPORT. ALWAYS HANDLE THESE AREAS CAREFULLY DURING INSTALLATION TO PREVENT BENDING OR DAMAGE TO THE METAL.

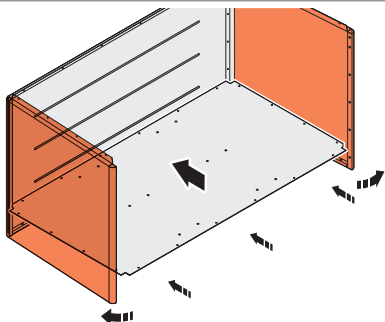

2A

NOTE: SLIGHT OUTWARD ADJUSTMENT OF SIDE PANELS MAYBE REQUIRED. LOCATE FLOOR PANEL AND CAREFULLY POSITION BETWEEN SIDE PANELS.

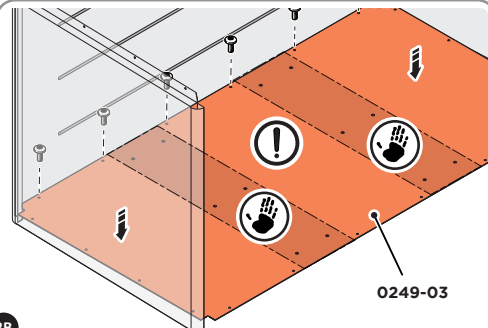

2B

NOTE: ONCE LOWERED INTO POSITION, LOOSELY ATTACH AT (x6) LOCATIONS. **NOTE:** IF APPLYING BODY WEIGHT TO FLOOR, ONLY USE AREAS INDICATED ABOVE, HAVE EXTRA STRENGTH AND SUPPORT.

Assembly Guide

ASSEMBLY STAGE 3

LOCATE AND LOOSELY ATTACH FRONT PANEL 0249-02, SECURE TO SIDE PANELS.



 CORRECT ORIENTATION.

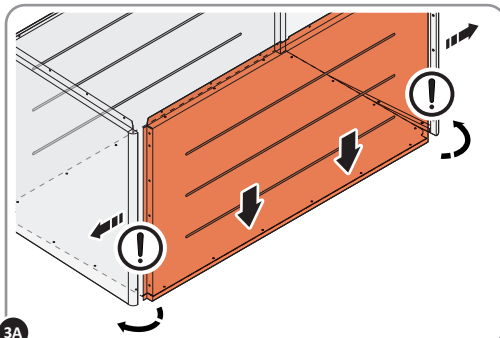
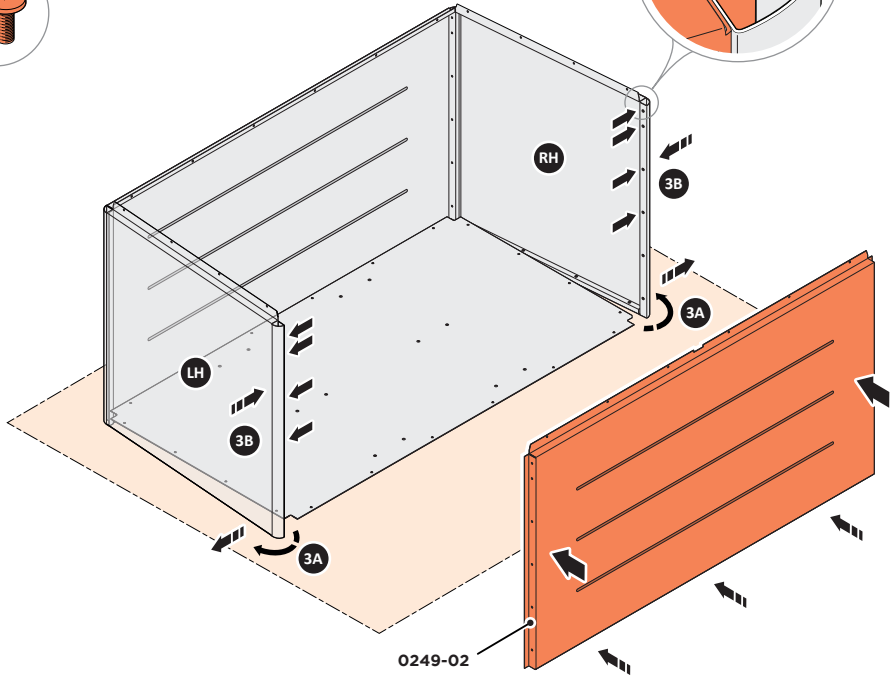

NOTE: APPLY A SLIGHT OUTWARD ADJUSTMENT TO THE SIDE PANELS. LOCATE FRONT PANEL AND CAREFULLY POSITION BETWEEN SIDE PANELS. SLIDE THE LOWER EDGE OF THE FRONT PANEL BENEATH THE FLOOR PANEL.

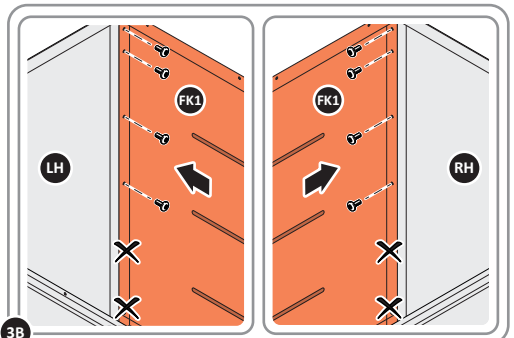

NOTE: ONCE FRONT PANEL IS IN POSITION, APPLY INWARD ADJUSTMENT TO SIDE PANELS. LOOSELY SECURE AT (x8) LOCATIONS INDICATED ABOVE.

Assembly Guide

ASSEMBLY STAGE 4

CAREFULLY ROTATE THE STORAGE BOX ONTO THE FRONT PANEL 0249-02 WITH THE FRONT PANEL FACING DOWNWARDS, ENSURING ALL SIDES ARE SECURED TO THE BASE PANEL 0249-03.

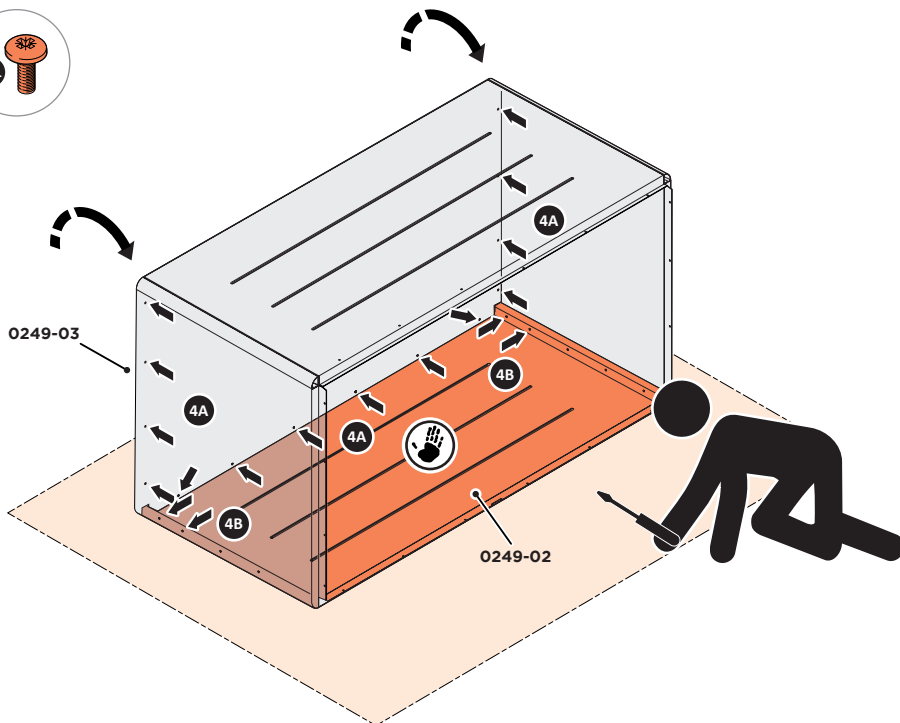

NOTE: THE HIGHLIGHTED PANEL AREA IS **NOT** REINFORCED. ALWAYS HANDLE THESE AREAS WITH EXTRA CARE, DURING INSTALLATION TO PREVENT BENDING OR DAMAGE TO THE METAL.

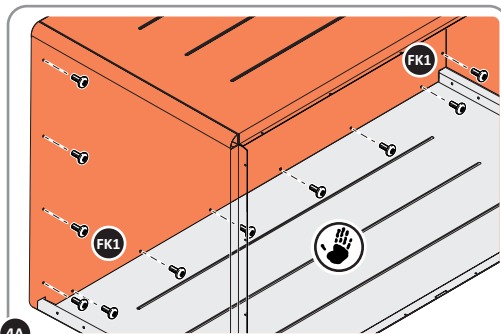

4A
NOTE: SECURE BASE PANEL 0249-03, USING FIXINGS SCREWS AT (x14) LOCATIONS INDICATED ABOVE. EXTRA CARE REQUIRED, DURING INSTALLATION.

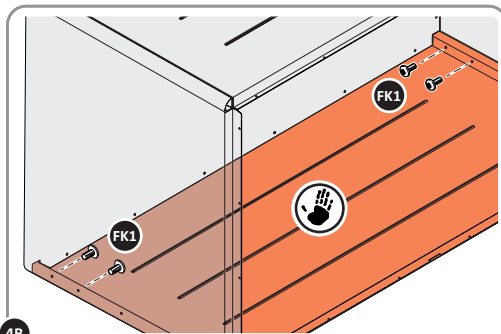

4B
NOTE: SECURE SIDE PANELS, USING FIXINGS SCREWS AT (x4) LOCATIONS INDICATED ABOVE.

ASSEMBLY STAGE 5

ON THE REAR BASE PANEL 0249-03, SECURE (x4) BOX FEET 0249-16.

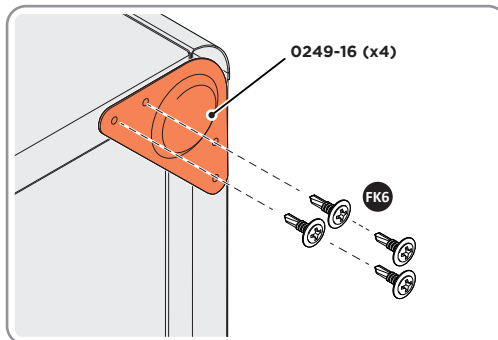
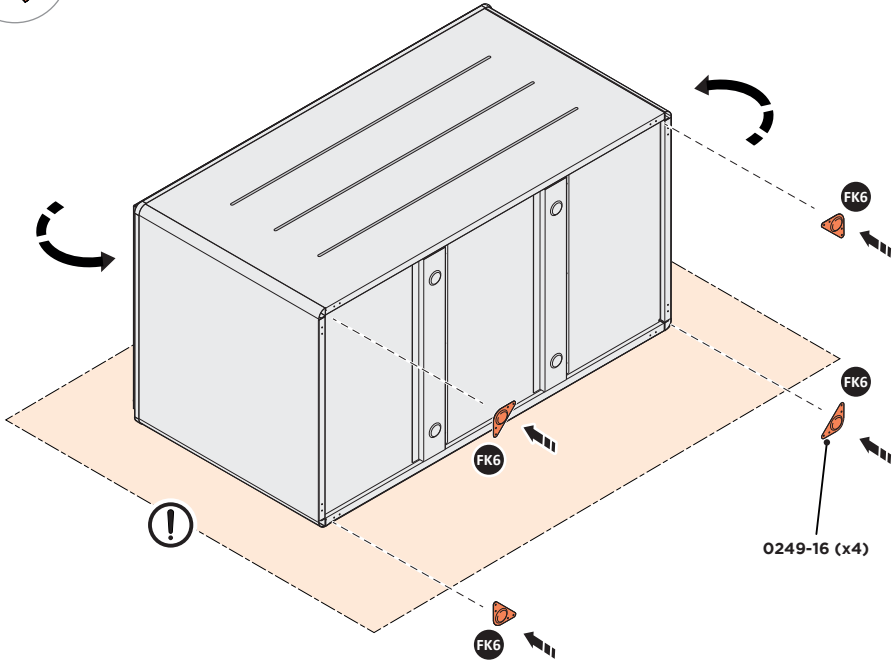

NOTE: LOCATE AND SECURE FEET 0249-16 TO BASE PANEL, AT (x4) LOCATIONS, INDICATED ABOVE. USE 13MM FIXINGS.

ASSEMBLY STAGE 6

CAREFULLY ROTATE THE STORAGE BOX BACK ONTO THE BASE, LOCATE AND SECURE FRAME 0249-04.

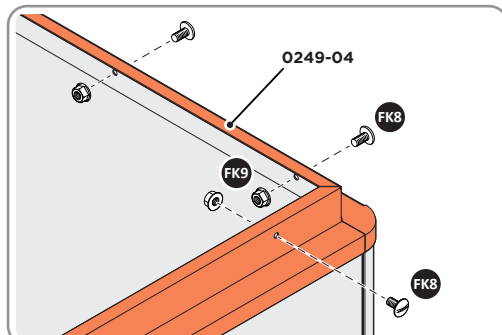
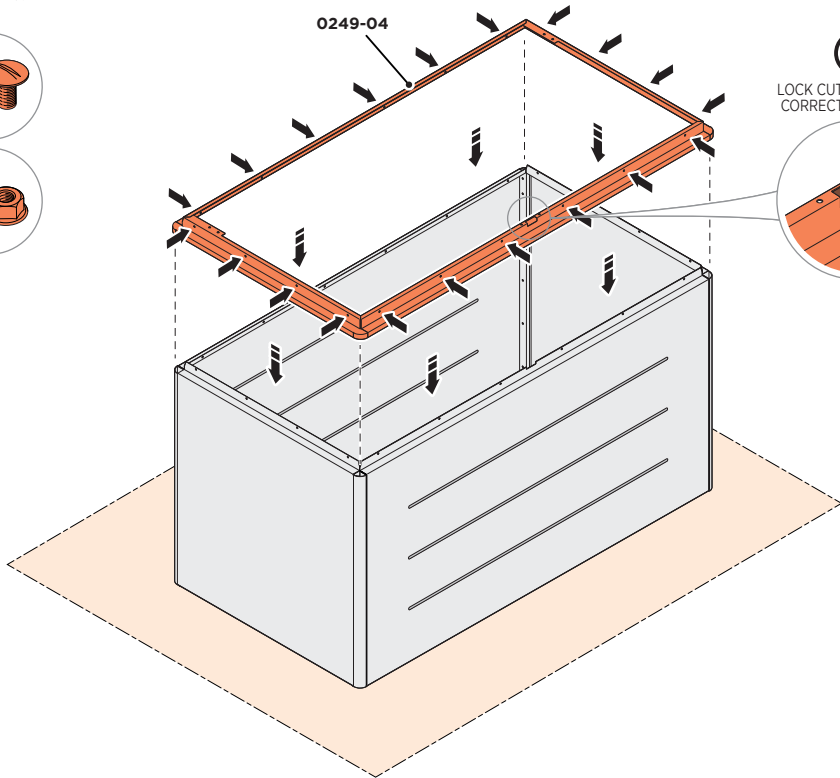

NOTE: MAKE SURE THE LOCK CUTAWAY IS IN THE CORRECT ORIENTATION. LOCATE AND SECURE FRAME 0249-04, AT LOCATIONS INDICATED ABOVE.

ASSEMBLY STAGE 7

LOCATE AND SECURE CATCH PLATE 0249-19.

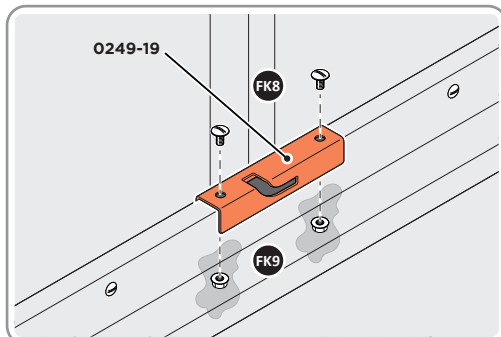
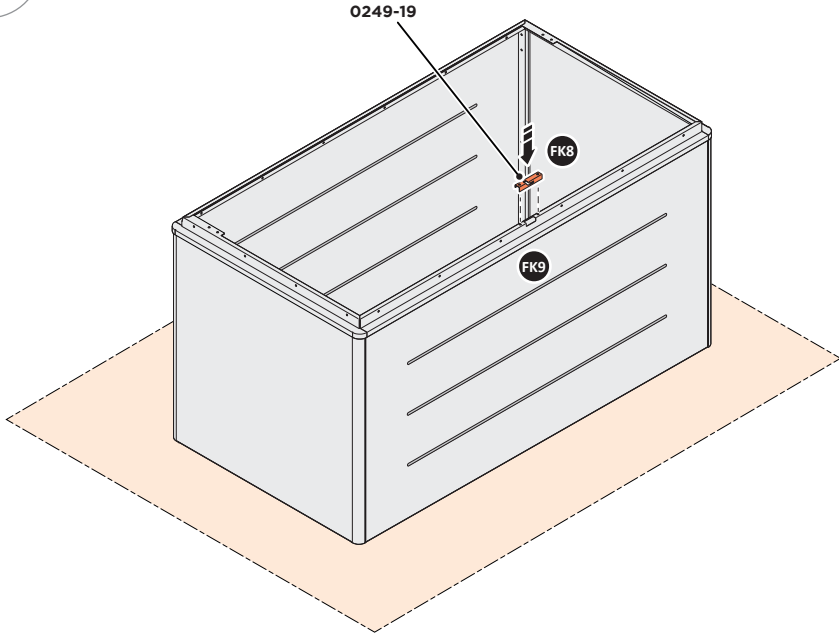

NOTE: MAKE SURE THE CATCH PLATE IS IN THE CORRECT ORIENTATION. LOCATE AND SECURE PLATE 0249-19, AT LOCATIONS INDICATED ABOVE.

Assembly Guide

ASSEMBLY STAGE 8 ASSEMBLY LID HINGES, AS SHOWN.

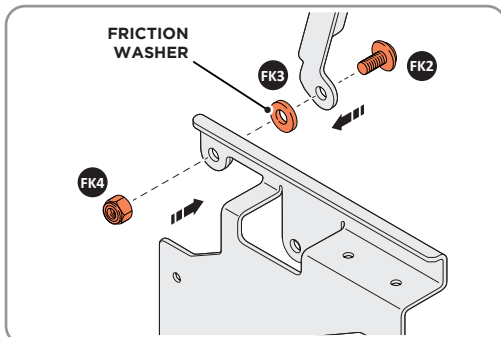
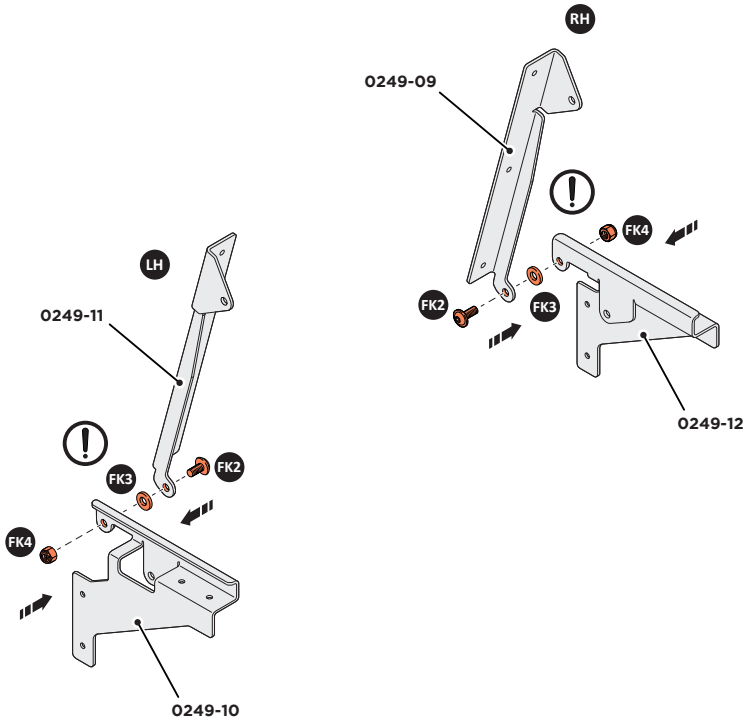

NOTE: ENSURE DURING ASSEMBLY THE FRICTION WASHER IS LOCATED BETWEEN THE BRACKET & HINGE.

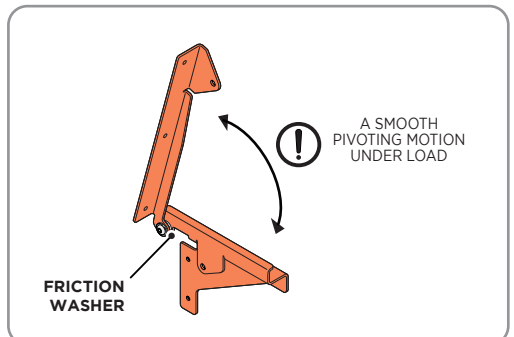

NOTE: AFTER TIGHTENING THE NUT & BOLT, ENSURE THE HINGE OPERATES SMOOTHLY WHILST MAINTAINING RESISTANCE ON THE FRICTION WASHER.

Assembly Guide

ASSEMBLY STAGE 9

SECURE GAS STRUTS 0249-26 TO LID HINGES.

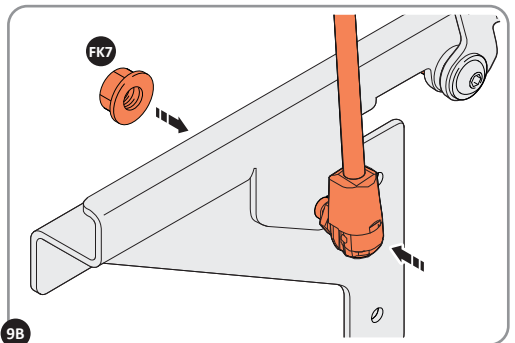
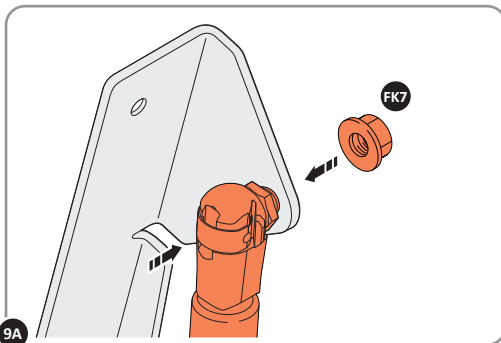
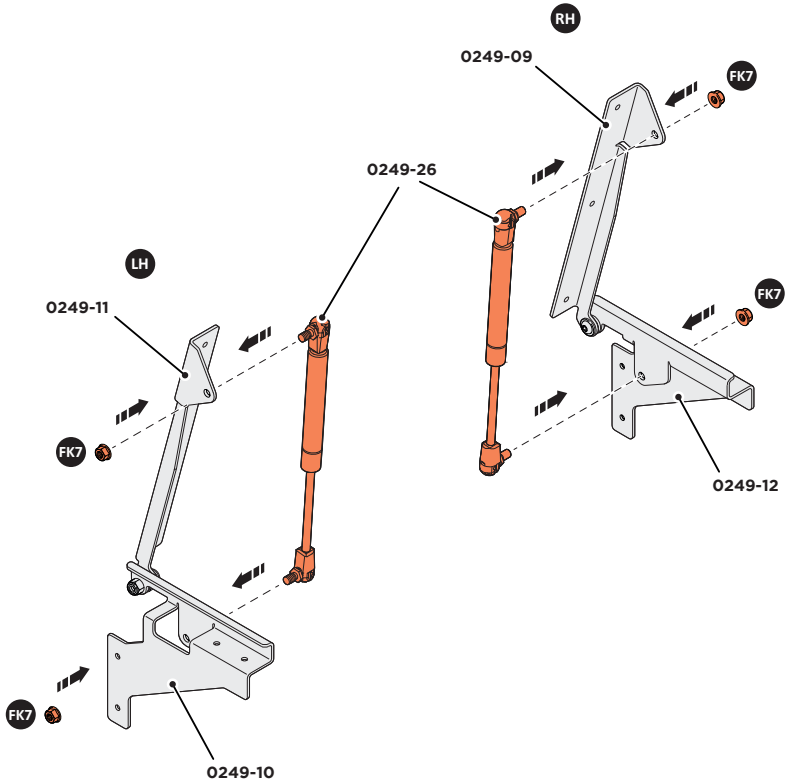

SECURE GAS STRUTS 0249-26 TO LH & RH LID HINGES, AT LOCATIONS SHOWN ABOVE. USING M8 FIXING NUT.

Assembly Guide

ASSEMBLY STAGE 10

ROTATE BOX FRAME TO IT'S UPRIGHT POSITION. SECURE GAS STRUT & LID HINGE ASSEMBLIES TO PANELS & FRAME AS SHOWN.

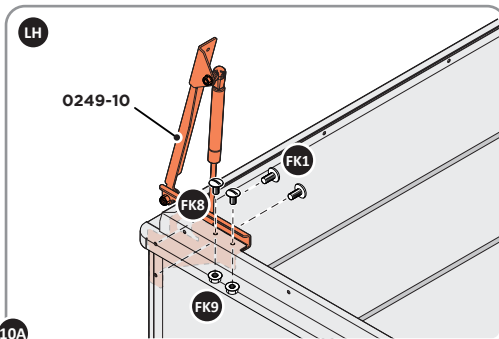
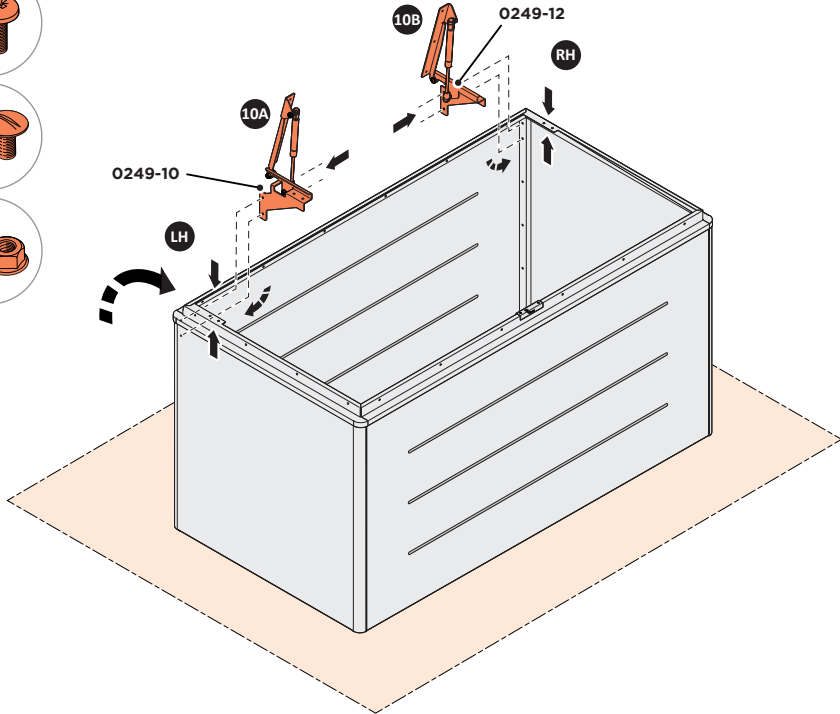

10A SECURE LID HINGE ASSEMBLY 0249-10, AT (x2) LOCATIONS INDICATED ABOVE.

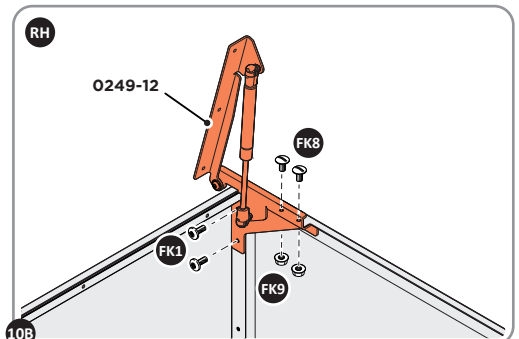

10B SECURE LID HINGE ASSEMBLY 0249-12, AT (x2) LOCATIONS INDICATED ABOVE.

ASSEMBLY STAGE 11

LOCATE LID AND SECURE RUBBER FEET & SPACERS.

NOTE: TO AVOID DAMAGE TO THE PAINTED FINISH, WE RECOMMEND PLACING THE PRODUCT ON A SCRATCH-RESISTANT SURFACE.

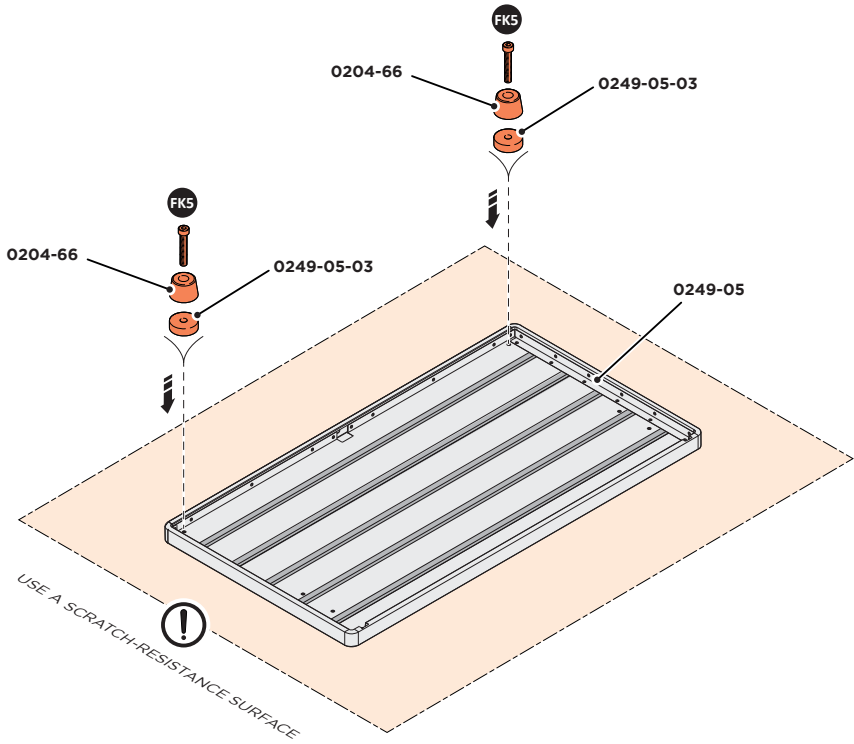

ASSEMBLY STAGE 12

LOCATE AND SECURE CAM LOCK 0249-23, CATCH PLATE 0249-24 & BACKING PLATE 0249-25 TO LID.

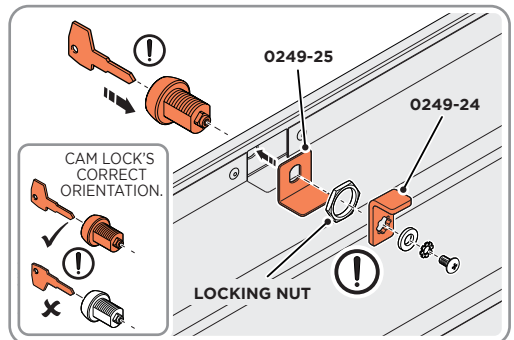
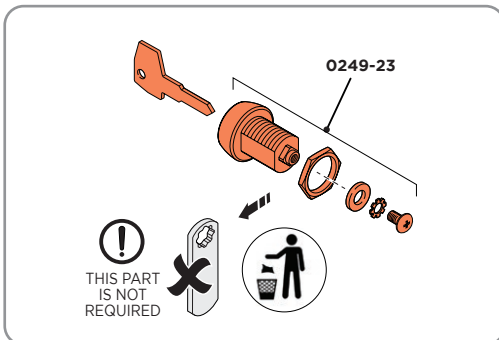
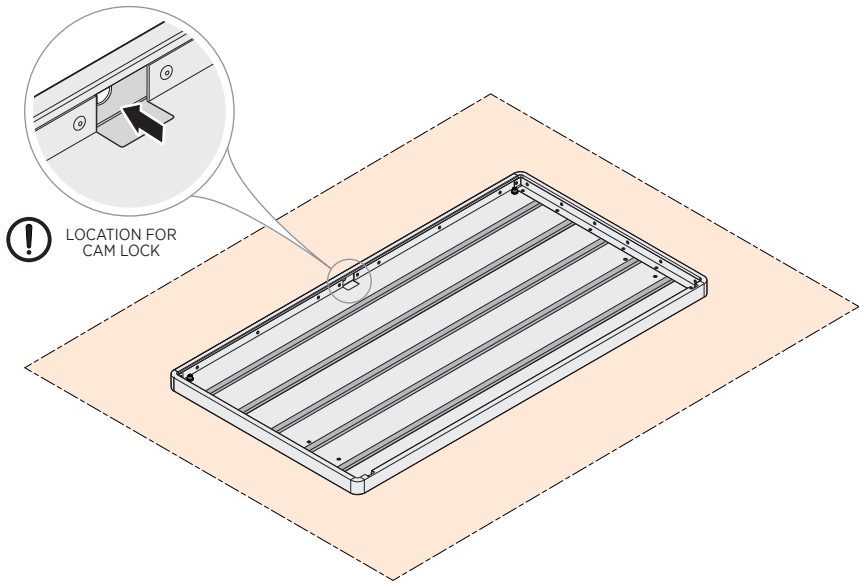
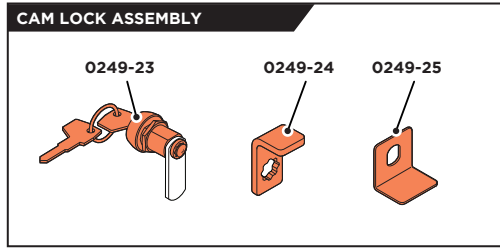

LOCATE AND DISASSEMBLE THE CAM LOCK ASSEMBLY 0249-23.
NOTE: THE METAL PART HIGHLIGHTED IS NOT REQUIRED.

WITH THE LID IN THE UPSIDE DOWN POSITION, SECURE LOCK BACKING PLATE 0249-25 AND CAM LOCK ASSEMBLY TO LID AS SHOWN ABOVE.
NOTE: M22 SOCKET WILL BE REQUIRED FOR LOCKING NUT.

Assembly Guide

ASSEMBLY STAGE 13

LOCATE LID 0249-05 AND SECURE TO LID HINGES 0249-10 & 0249-12.

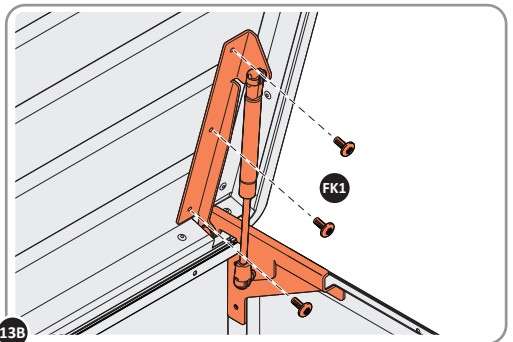
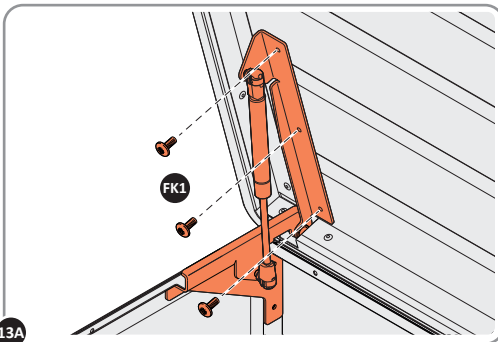
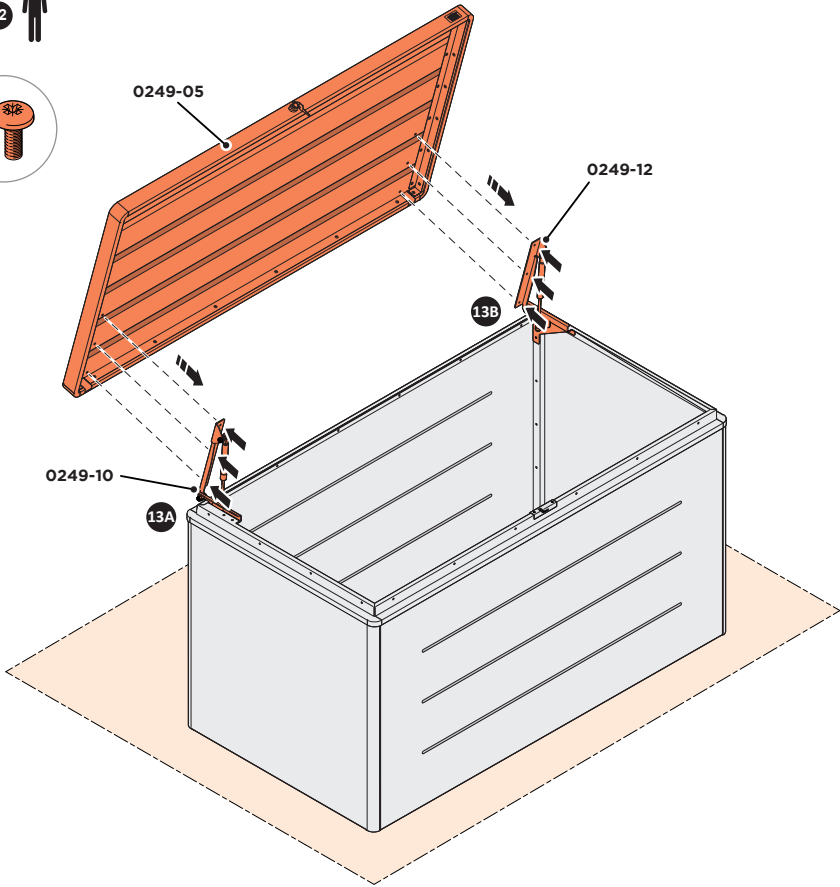

13A SECURE LID TO BOTH LID HINGES. AT (x3) LOCATIONS INDICATED ABOVE.

ASSEMBLY STAGE 14

FINISHED ASSEMBLY.

ENSURE THAT THE LID OPERATION OPENS AND CLOSES CORRECTLY. MINOR ADJUSTMENTS MAY BE REQUIRED IF THE LOCKING MECHANISM SECURE PLATE 0249-19 DOES NOT ENGAGE PROPERLY.

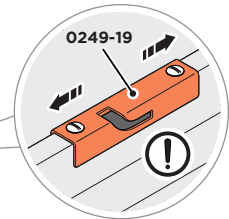
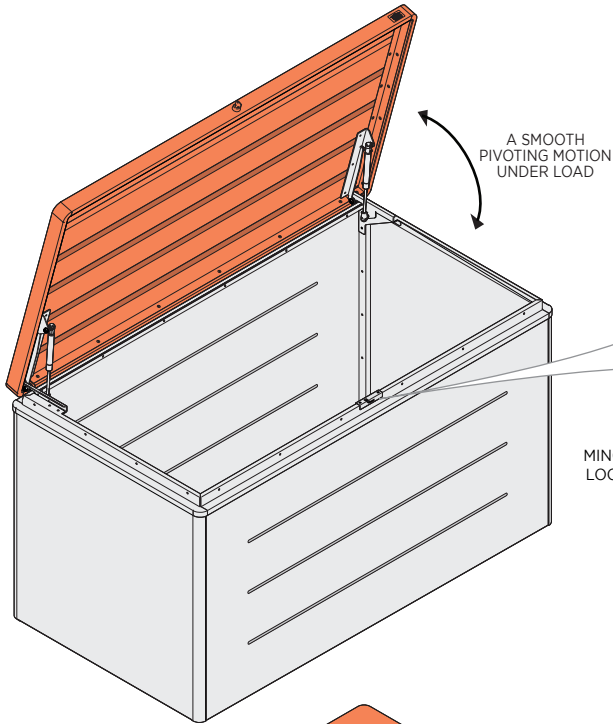

MINOR ADJUSTMENT MAY BE REQUIRED. LOOSEN SCREWS, ADJUST MECHANISM, THEN FULLY RE-TIGHTEN.

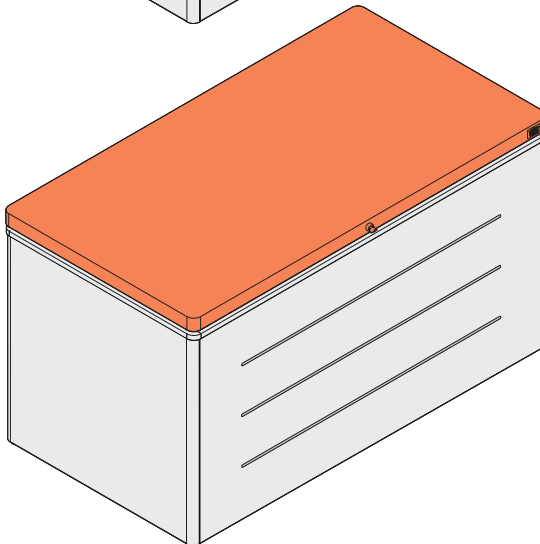

Caring for your HEX Living product

Your **HEX Living product** is designed to stand the test of time, which is why we're happy to offer a **lifetime warranty** on our products. With zero maintenance required, simply assemble your HEX Living product, and enjoy putting it to great use in your garden.

Periodically, you might want to give your product a clean, these simple care tips are not essential to the performance of your product:

- Remove surface dirt with plain water using a jet wash or sponge, the coating on our products will ensure dirt or mud simply wipes away.
- If you've purchased a HEX Living metal storage solution, periodically clear the lid of fallen leaves.

Ensure you have registered your HEX Living product

Using the unique serial number found on the cover of this document, please visit www.hexliving.co.uk to register your product and access the HEX Living lifetime warranty and support.

Customer Service: +44 (0) 1889 272 056

