

Bromley

Horizontal Metal Storage Shed Assembly Guide



IMPORTANT: PLEASE REGISTER YOUR HEX LIVING PRODUCT AFTER ASSEMBLY

Using the unique serial number, simply register your product at www.hexliving.co.uk or use the QR code above to access the HEX Living lifetime warranty and online support.

Affix Serial Number
HERE



PLEASE READ THIS DOCUMENT FULLY PRIOR TO STARTING ASSEMBLY PROCEDURE

The objective of this instruction is to illustrate the recommended assembly sequence for this product, any deviation from this will be the sole responsibility of whoever carries out the assembly.

IMPORTANT: IT IS ADVISABLE THAT THE PRODUCT IS ASSEMBLED AT, OR AS CLOSE AS POSSIBLE TO WHERE IT WILL BE FINALLY LOCATED

Ensure there is adequate clearance where the product is to be located:

Exterior dimensions including overhang (W x D x H)	1950 x 1000 x 1358mm
Footprint dimensions (W x D)	1900 x 900mm
Clearance required for door to open (W x H)	Doors open outwards 1655 x 1254mm
Clearance required for lid to open (W x H)	Lid opens 1950 x 2165mm

TWO PERSON ASSEMBLY

Most procedures will not require two people but it may be easier to have assistance.



PERSONAL PROTECTION EQUIPMENT

We advise appropriate personal protective equipment is worn during assembly including eye protection and gloves.



CARING FOR YOUR HEX LIVING PRODUCT

Your **HEX Living** product is designed to stand the test of time, which is why we're happy to offer a lifetime warranty on our products. With zero maintenance required, simply assemble your HEX Living product and enjoy putting it to great use in your garden.

Periodically, you might want to give your product a clean, these simple care tips are not essential to the performance of your product:

- Remove surface dirt with plain water using a jet wash or sponge, the coating on our products will ensure dirt or mud simply wipes away.
- Periodically clear the lid of fallen leaves.
- If your product has guttering, remove leaves and garden debris as you would on your home.

PRODUCT REGISTRATION

IMPORTANT: Prior to assembly, please ensure you have registered your HEX Living product using the unique serial number found on the cover of this document, please visit www.hexliving.co.uk to register your product and access the HEX Living lifetime warranty and video instructions.

GROUND ANCHOR KIT

A Ground Anchor Kit is supplied, this is to secure the product to a solid concrete base, the shed has x4 clamp plates in each corner.

WE STRONGLY ADVISE THAT THE SHED IS ANCHORED USING THIS KIT

The diagram illustrates the typical fixing method, once the shed is assembled, access the clamp brackets by removing the appropriate floor panel and secure as required.

GROUND ANCHOR KIT

Part Ref: FK8
M8 x 50mm Coach Screw
Qty: x4



Part Ref: FK7
Expansion Plug
Qty: x4

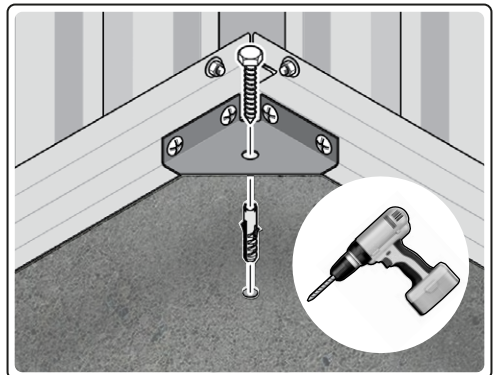

Assembly Guide

ENSURE ALL ITEMS LISTED ARE PRESENT PRIOR TO STARTING ASSEMBLY PROCEDURE

SCALE OF ITEMS WILL VARY TO AID VISUAL IDENTIFICATION

Part Ref: 0204-01
Qty: x2

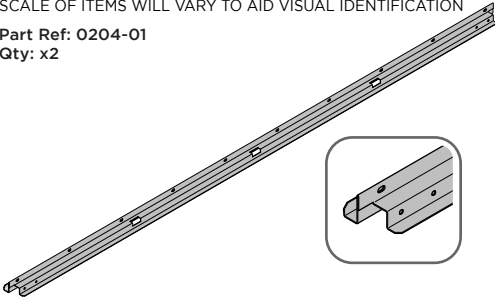

Part Ref: 0204-05
Qty: x1

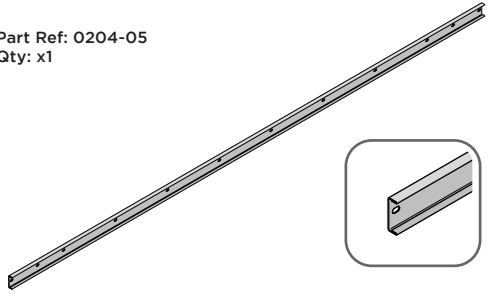

Part Ref: 0204-02
Qty: x2

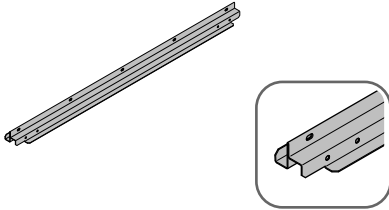

Part Ref: 0204-10 (1237mm Long)
Qty: x2

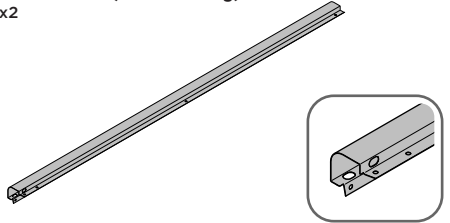

Part Ref: 0203-03
Qty: x4



Part Ref: 0204-71
Qty: x1

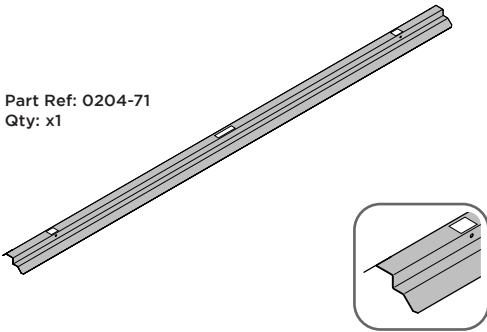

Part Ref: 0204-11 (1302mm Long)
Qty: x2

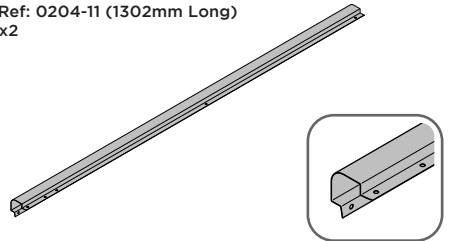

Part Ref: 0204-06
Qty: x2

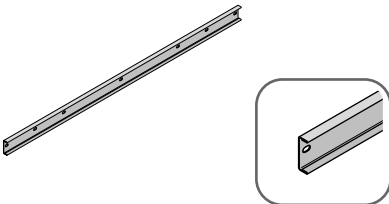

Part Ref: 0204-67
Qty: x1

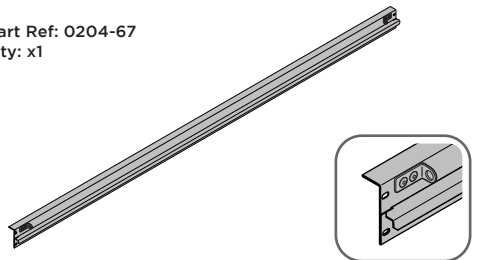

Assembly Guide

ENSURE ALL ITEMS LISTED ARE PRESENT PRIOR TO STARTING ASSEMBLY PROCEDURE

SCALE OF ITEMS WILL VARY TO AID VISUAL IDENTIFICATION

Part Ref: 0204-18
Qty: x1

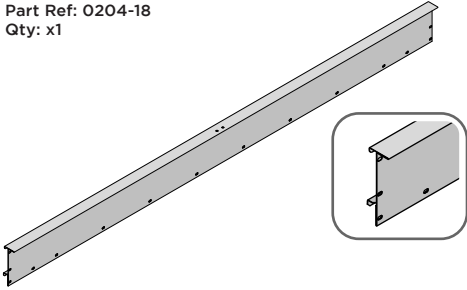

Part Ref: 0204-19 (L/H)
Qty: x1

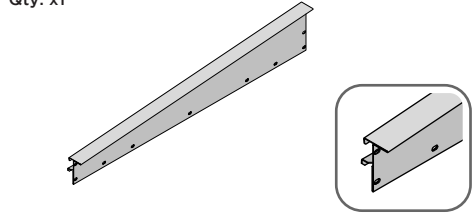

Part Ref: 0204-12 (R/H)
Qty: x1

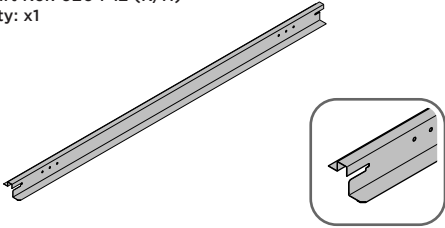

Part Ref: 0204-08 (824mm Wide)
Qty: x2

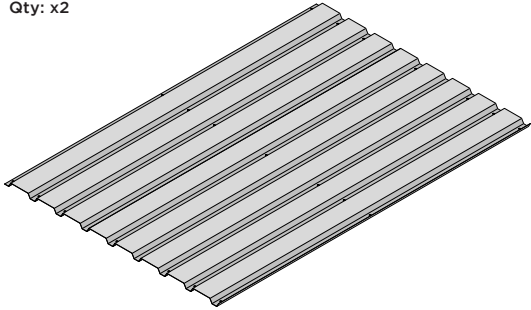

Part Ref: 0204-13 (L/H)
Qty: x1

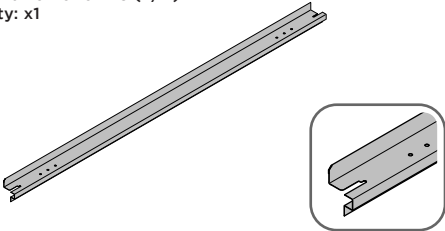

Part Ref: 0204-09 (625mm Wide)
Qty: x2

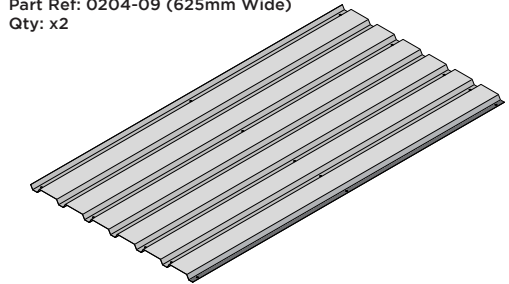

Part Ref: 0204-15 (R/H)
Qty: x1

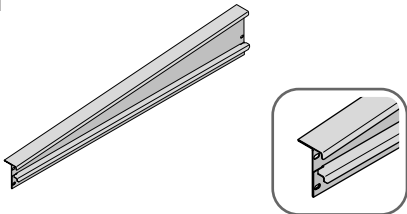

Part Ref: 0204-54 (616mm Wide)
Qty: x1

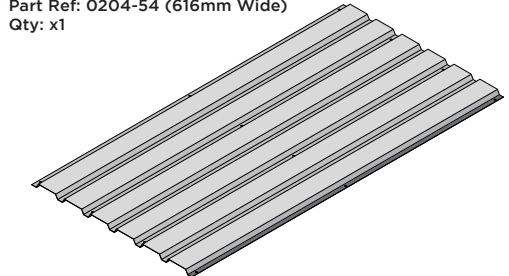

Assembly Guide

ENSURE ALL ITEMS LISTED ARE PRESENT PRIOR TO STARTING ASSEMBLY PROCEDURE

SCALE OF ITEMS WILL VARY TO AID VISUAL IDENTIFICATION

Part Ref: 0204-17
Qty: x1

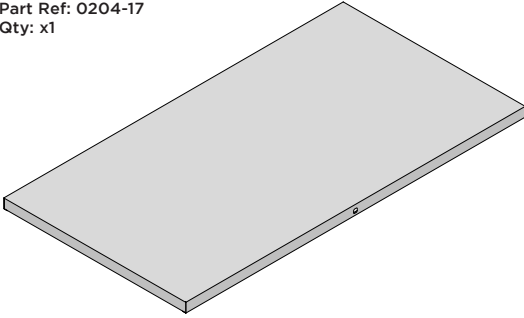

Part Ref: 0204-33
Qty: x2

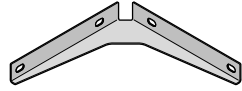

Part Ref: 0204-34
Qty: x2

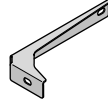

Part Ref: 0204-21 (R/H)
Qty: x1

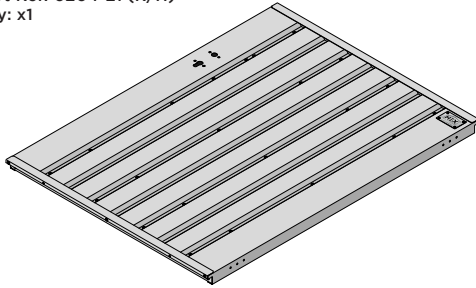

Part Ref: 0204-23
Qty: x1

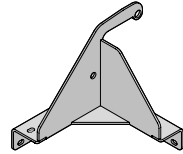

Part Ref: 0204-22 (L/H)
Qty: x1

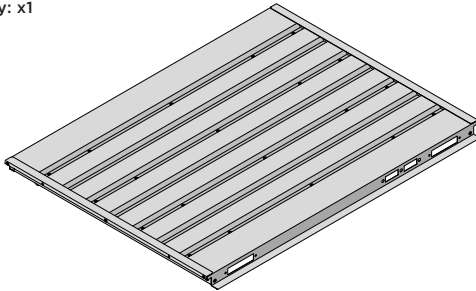

Part Ref: 0204-24
Qty: x1

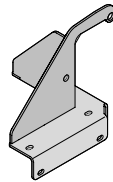

Part Ref: 0204-59
Qty: x2

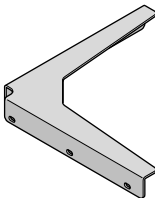

Part Ref: 0204-47
Qty: x1

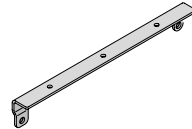

Part Ref: 0204-50
Qty: x1

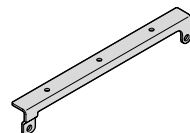

Assembly Guide

ENSURE ALL ITEMS LISTED ARE PRESENT PRIOR TO STARTING ASSEMBLY PROCEDURE

SCALE OF ITEMS WILL VARY TO AID VISUAL IDENTIFICATION

Part Ref: 0204-46
Qty: x1



Part Ref: 0204-56
Qty: x1

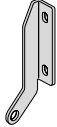

Part Ref: 0205-66
Qty: x2

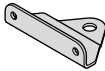

Part Ref: 0204-30
Qty: x4



Part Ref: 0204-62
Qty: x3



Part Ref: 0204-63
Qty: x3

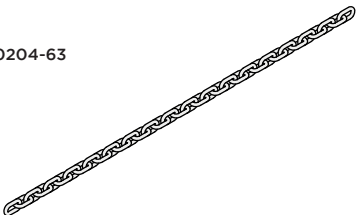

Part Ref: 0204-65
Qty: x6



Part Ref: 0205-68
Qty: x8



Part Ref: 0205-63
Qty: x2

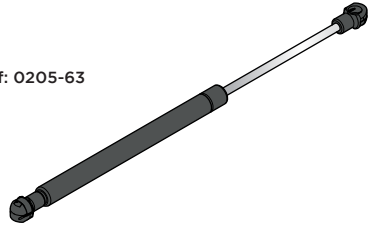

Part Ref: 0204-25
Qty: x2

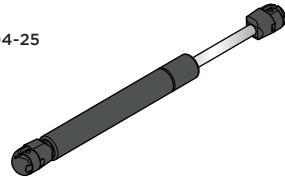

Part Ref: 0204-57
Qty: x2

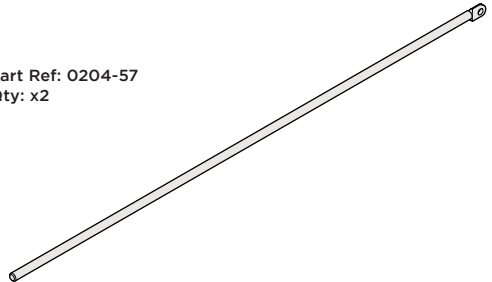

Part Ref: 0204-58 (Assembly)
Qty: x1

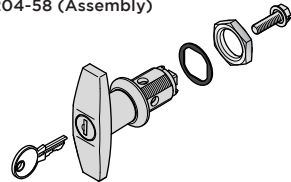

Part Ref: 0206-28 (Assembly)
Qty: x1

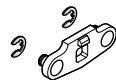

Assembly Guide

ENSURE ALL ITEMS LISTED ARE PRESENT PRIOR TO STARTING ASSEMBLY PROCEDURE

SCALE OF ITEMS WILL VARY TO AID VISUAL IDENTIFICATION

Part Ref: 0203-40
Qty: x4



Part Ref: 511-0023
Qty: x4



Part Ref: 0203-33 (Assembly)
Qty: x1

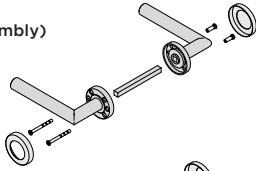

Part Ref: 0204-51
Qty: x2



Part Ref: 0204-66
Qty: x2



Part Ref: 0203-34 (Assembly)
Qty: x1

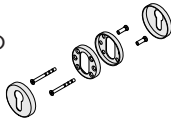

FIXING KIT: 0204-64

Part Ref: FK1
M4 x 10mm Roofing Bolt
Qty: x107



Part Ref: 0203-35
Qty: x2

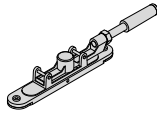

Part Ref: FK2
M4 x 12mm Roofing Bolt
Qty: x22



Part Ref: 0203-36
Qty: x1



Part Ref: FK3
No.8 x 13mm Eco Fix
Qty: x7



Part Ref: FK4
M4 x 12mm C'Sunk Pozi Pan
Qty: x30



Part Ref: 0203-37
Qty: x8

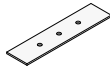

Part Ref: FK5
M5 x 16mm Button Head Socket
Qty: x11



Part Ref: 0203-28 (L/H Assembly)
Qty: x2



Part Ref: FK6
M8 x 20mm Button Head Socket
Qty: x4



Part Ref: 0203-27 (R/H Assembly)
Qty: x2



Part Ref: FK7
M4 Serrated Flange Nut
Qty: x129



Part Ref: FK8
M8 Serrated Flange Nut
Qty: x9



Part Ref: 0203-32 (Assembly)
Qty: x1

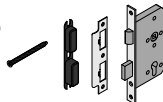

Part Ref: FK9
M8 Nyloc Nut
Qty: x4



Part Ref: FK10
Expansion Plug
Qty: x4



Part Ref: 0203-41
Qty: x1

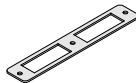

Part Ref: FK11
M8 x 50mm Coach Screw
Qty: x4

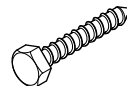

Part Ref: 0203-57
Qty: x4



Part Ref: FK12
M4 x 16mm Cap Screw
Qty: x2



Assembly Guide

ASSEMBLY STAGE 1

LOCATE AND SECURE A CORNER BRACE 0203-03 AT EACH LOCATION INDICATED.

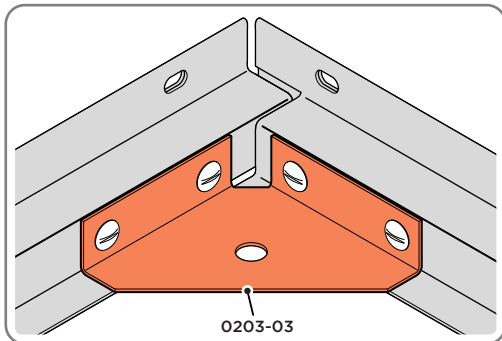
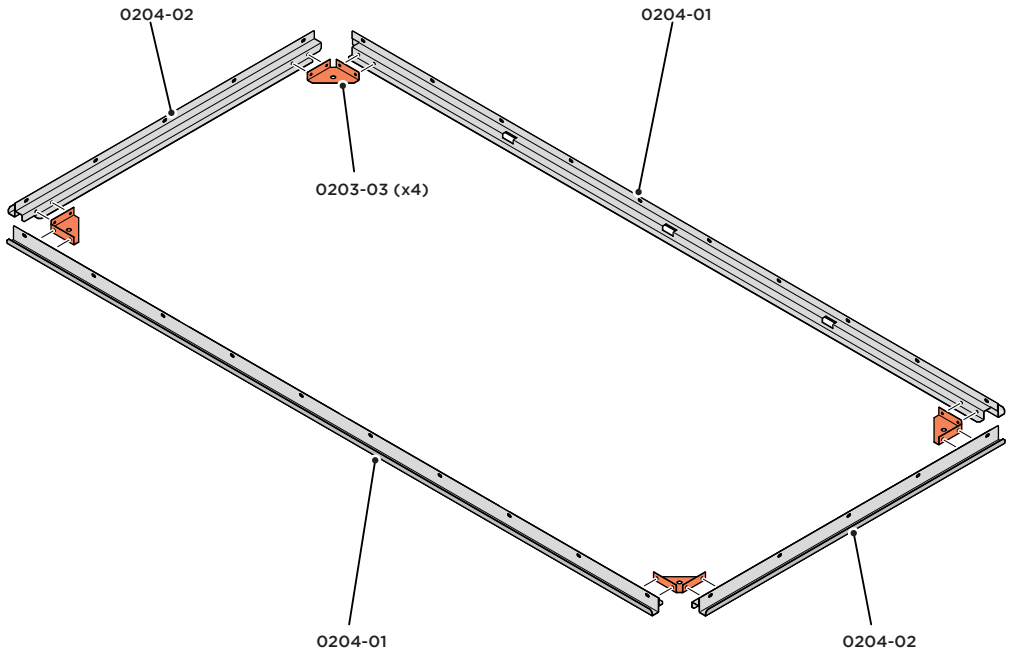

SECURE EACH CORNER BRACE 0203-03 AS SHOWN ABOVE.

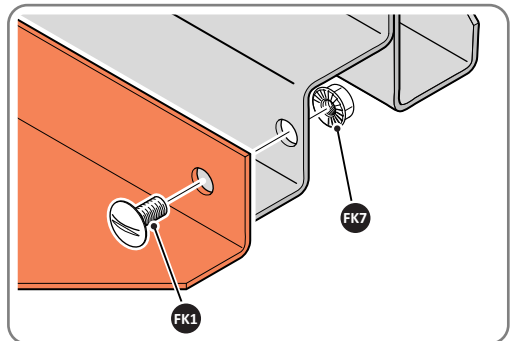

PLEASE NOTE: SECTION VIEW OF TYPICAL FIXING METHOD.

Assembly Guide

ASSEMBLY STAGE 2

LOCATE SIDE WALL PANEL 0204-08 (824mm WIDE), PLEASE NOTE EACH PANEL DOES NOT HAVE A SPECIFIC TOP OR BOTTOM SO CAN BE LOCATED EITHER WAY.

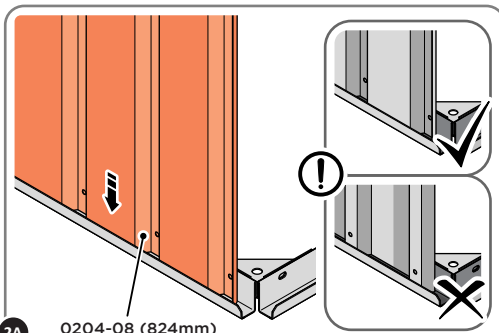
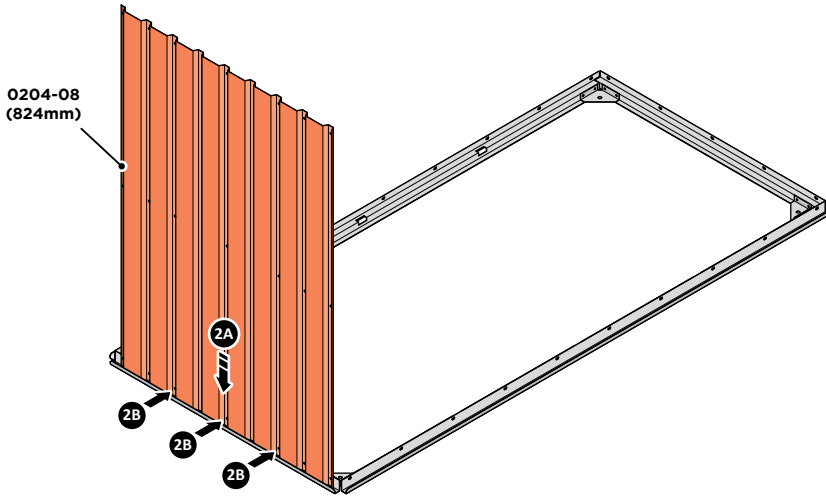

2A LOCATE SIDE WALL PANEL 0204-08 INTO POSITION AS SHOWN ABOVE.
IMPORTANT: ENSURE PANEL IS IN THE CORRECT ORIENTATION.

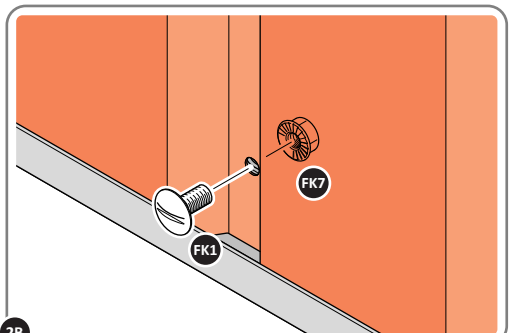

2B LOOSELY ATTACH SIDE WALL PANEL ONTO FLOOR RAIL AT X3 LOCATIONS INDICATED.
IMPORTANT: ONLY ATTACH AT FIXING POINTS INDICATED AT THIS STAGE.

ASSEMBLY STAGE 3

LOCATE AND LOOSELY ATTACH SHORT CENTRE BRACE 0204-06 ONTO SIDE WALL.

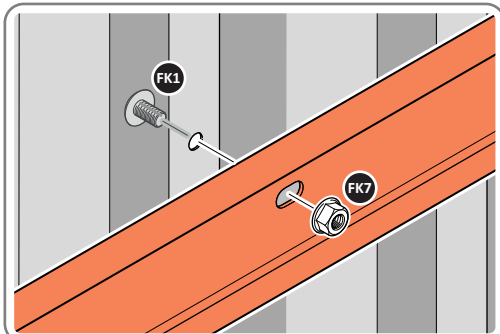
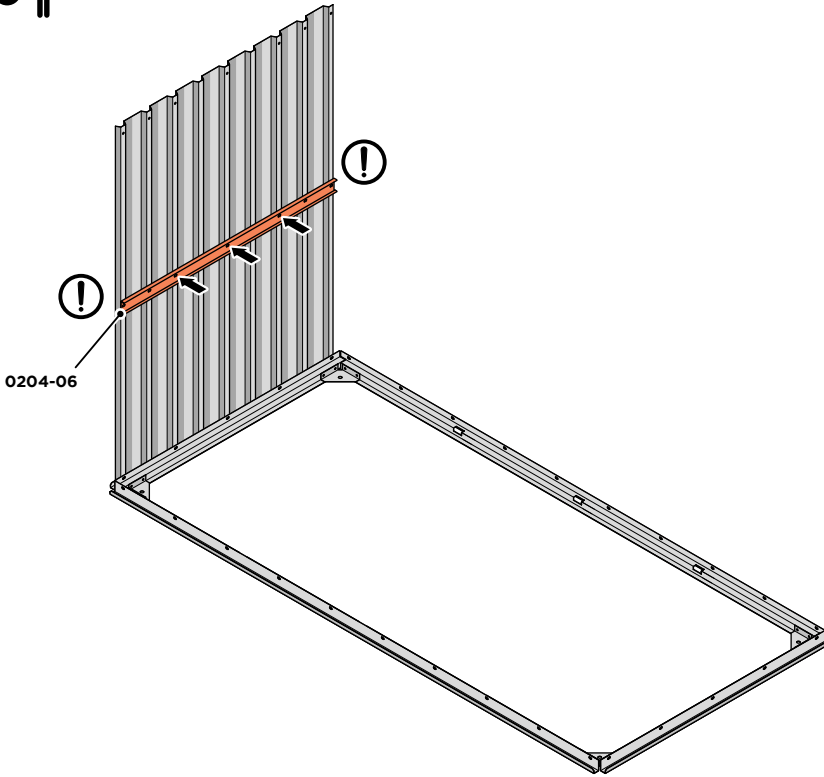

LOCATE AND LOOSELY ATTACH SHORT CENTRE BRACE 0204-06 AS SHOWN AT x3 LOCATIONS INDICATED ABOVE.

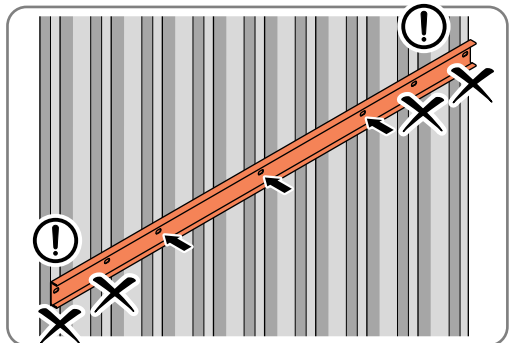

LOOSELY ATTACH AT x3 LOCATIONS INDICATED ONLY.
IMPORTANT: ONLY ATTACH AT FIXING POINTS INDICATED AT THIS STAGE.

Assembly Guide

ASSEMBLY STAGE 4

LOCATE AND LOOSELY ATTACH CORNER POSTS 0204-10 (1237mm) & 0204-11 (1302mm LONG) ONTO SIDE WALL.



0204-11 (1302mm LONG)
x3 HOLES AT TOP

0204-10 (1237mm LONG)
x2 HOLES & LARGE OBOUNDR AT TOP

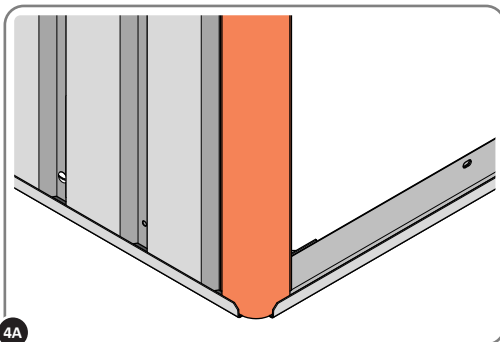
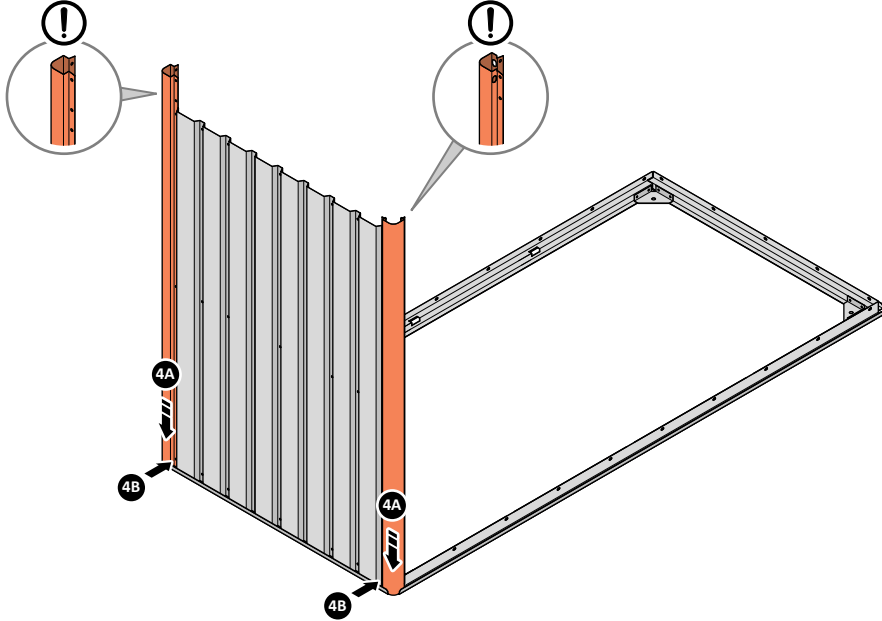

4A
LOCATE CORNER POSTS 0204-10 & 0204-11 AS SHOWN AT x2 LOCATIONS ABOVE.

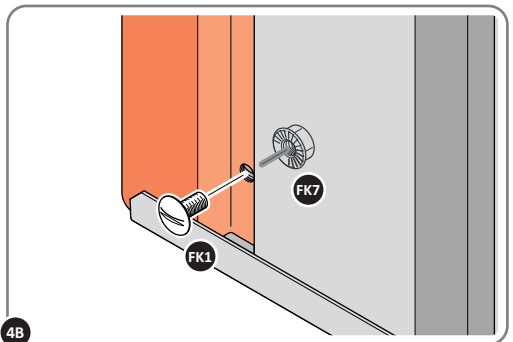

4B
LOOSELY ATTACH CORNER POSTS AT x2 LOCATIONS INDICATED ONLY.
IMPORTANT: ONLY ATTACH AT FIXING POINTS INDICATED AT THIS STAGE.

ASSEMBLY STAGE 5

LOCATE BACK WALL PANEL 0204-09 (625mm WIDE), PLEASE NOTE THE PANEL DOES NOT HAVE A SPECIFIC TOP OR BOTTOM BUT ENSURE IT IS LOCATED AS INSTRUCTED.

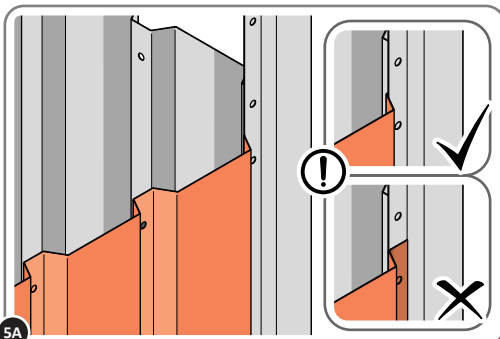
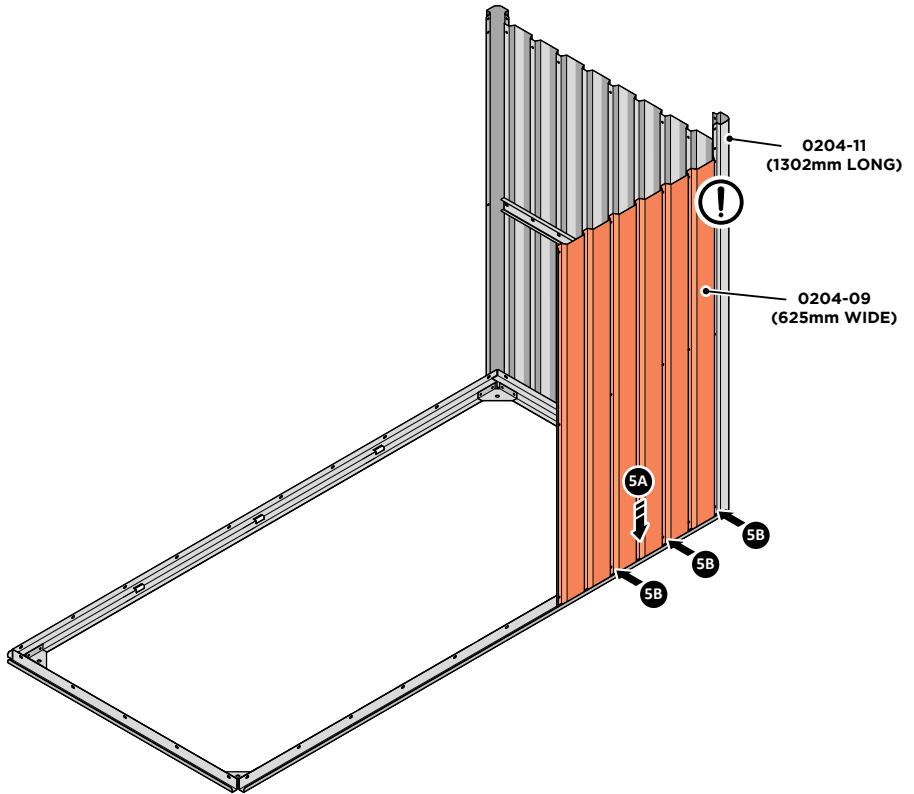

LOCATE FIRST BACK WALL PANEL 0204-09 (625mm WIDE) AS SHOWN ABOVE. **IMPORTANT: ENSURE PANEL IS IN THE CORRECT ORIENTATION.**

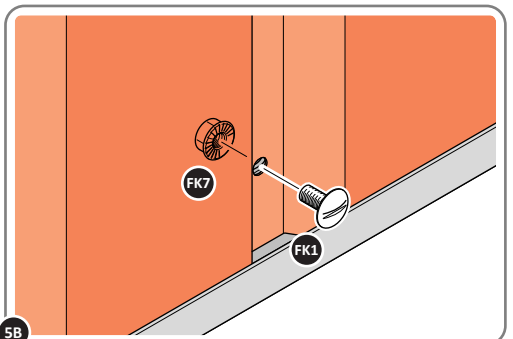

LOOSELY ATTACH BACK WALL PANEL AT x3 LOCATIONS INDICATED ONLY. **IMPORTANT: ONLY ATTACH AT FIXING POINTS INDICATED AT THIS STAGE.**

ASSEMBLY STAGE 6

LOCATE AND LOOSELY ATTACH LONG CENTRE BRACE 0204-05 ONTO BACK WALL PANEL.

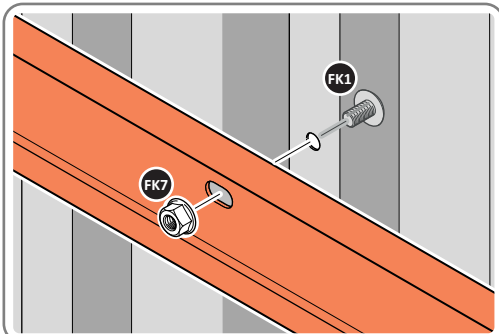
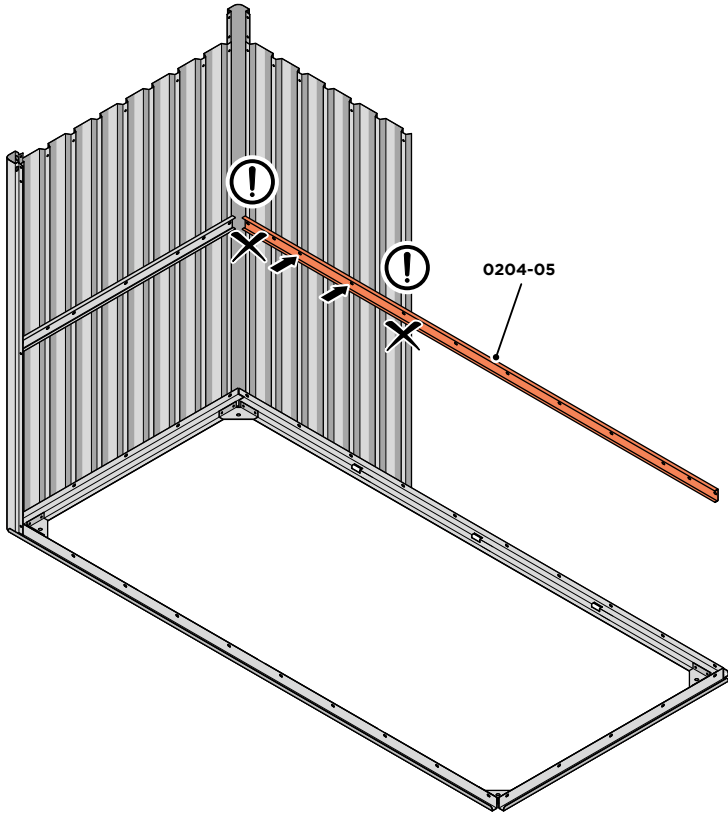

LOCATE AND LOOSELY ATTACH LONG CENTRE BRACE 0204-05 AS SHOWN AT X2 LOCATIONS INDICATED ABOVE ONLY.

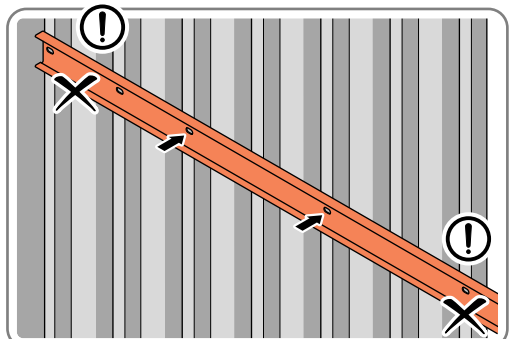

LOOSELY ATTACH AT X2 LOCATIONS INDICATED ONLY.
IMPORTANT: ONLY ATTACH AT FIXING POINTS INDICATED AT THIS STAGE.

ASSEMBLY STAGE 7

LOCATE BACK WALL MIDDLE PANEL 0204-54 (616mm WIDE), PLEASE NOTE THE PANEL DOES NOT HAVE A SPECIFIC TOP OR BOTTOM BUT ENSURE IT IS LOCATED AS INSTRUCTED.

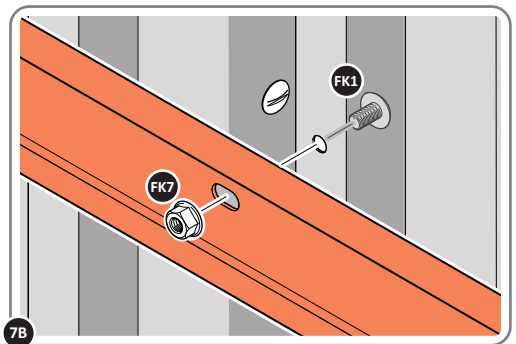
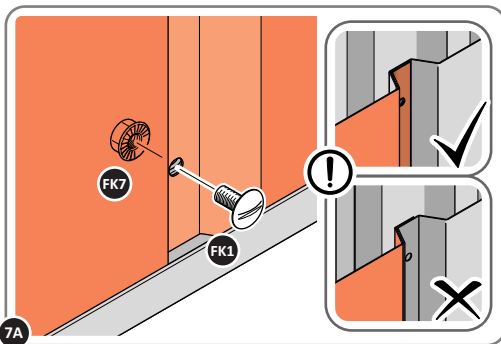
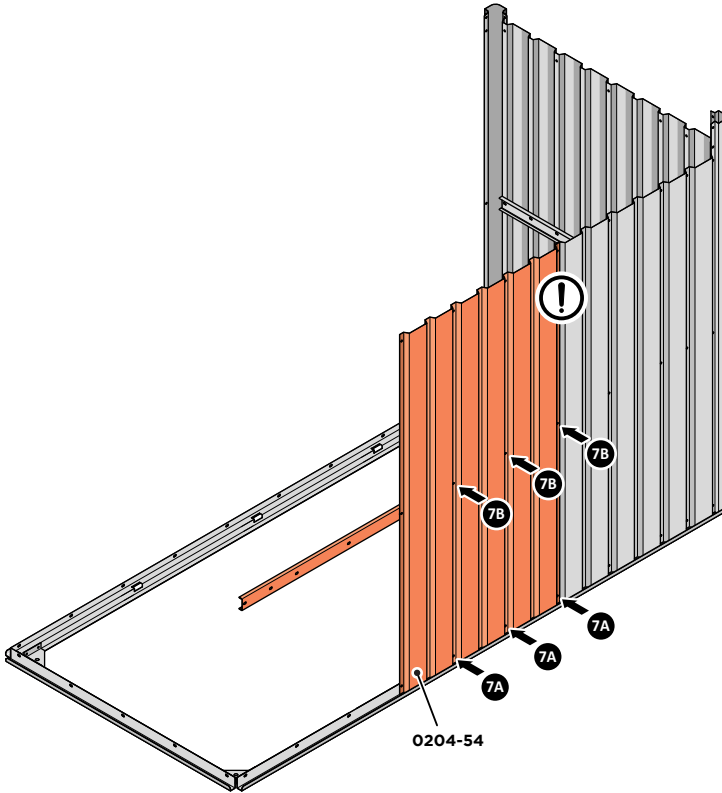

LOCATE AND LOOSELY ATTACH BACK WALL MIDDLE PANEL AT x3 LOCATIONS. **IMPORTANT: ENSURE PANEL IS IN THE CORRECT ORIENTATION.** LOOSELY ATTACH AT x3 LOCATIONS INDICATED ONLY.

Assembly Guide

ASSEMBLY STAGE 8

LOCATE BACK WALL PANEL 0204-09 (625mm WIDE), PLEASE NOTE THE PANEL DOES NOT HAVE A SPECIFIC TOP OR BOTTOM, BUT ENSURE IT IS LOCATED AS INSTRUCTED.

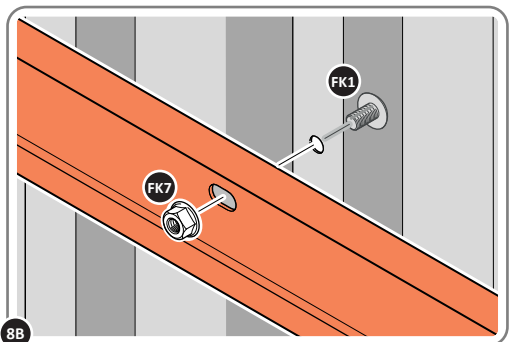
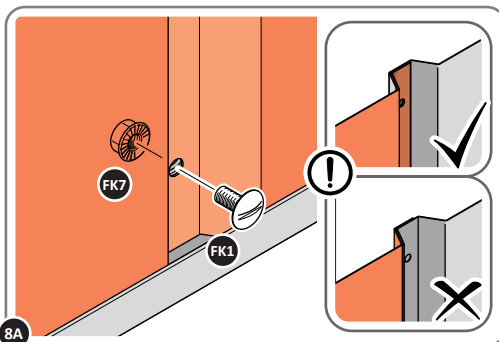
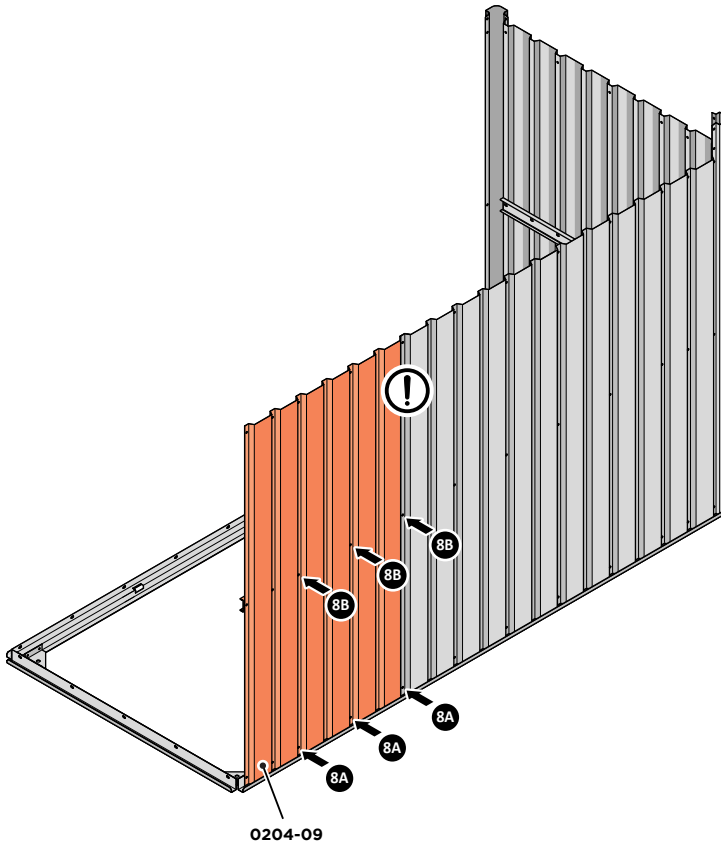

LOCATE AND LOOSELY ATTACH BACK WALL MIDDLE PANEL AT x3 LOCATIONS. IMPORTANT: ENSURE PANEL IS IN THE CORRECT ORIENTATION.

LOOSELY ATTACH AT x3 LOCATIONS INDICATED ONLY.

Assembly Guide

ASSEMBLY STAGE 9

LOCATE AND LOOSELY ATTACH CORNER POST 0204-11 (1302mm LONG) ONTO SIDE WALL.

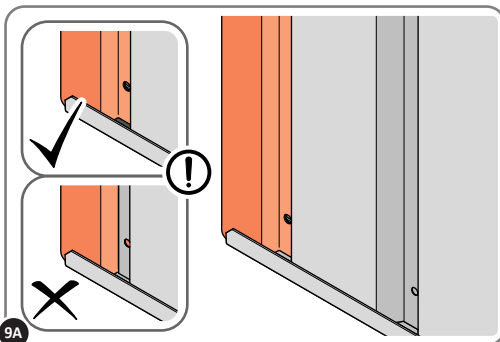
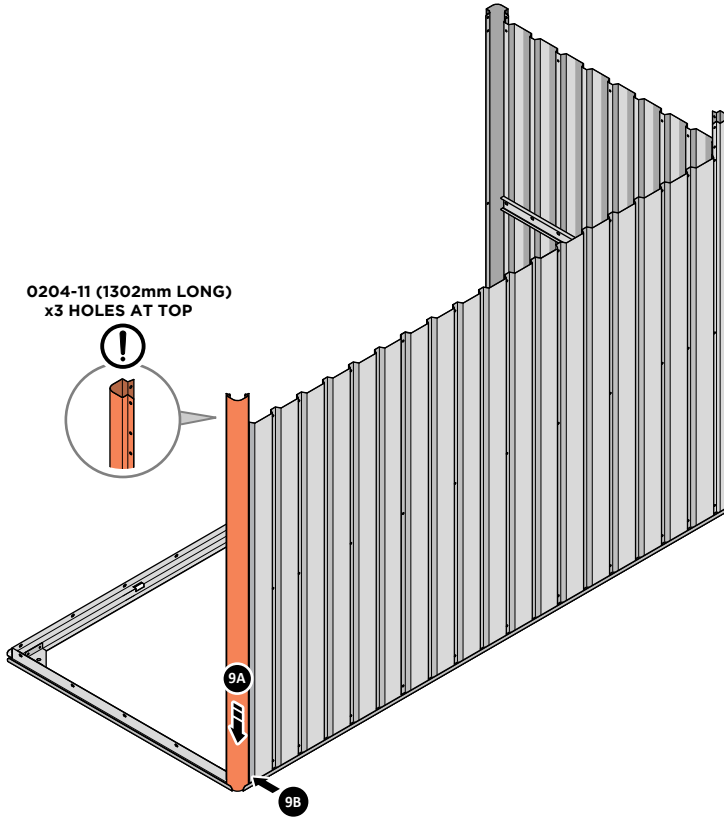

9A LOCATE CORNER POST 0204-11 (1302mm) AS SHOWN ABOVE.

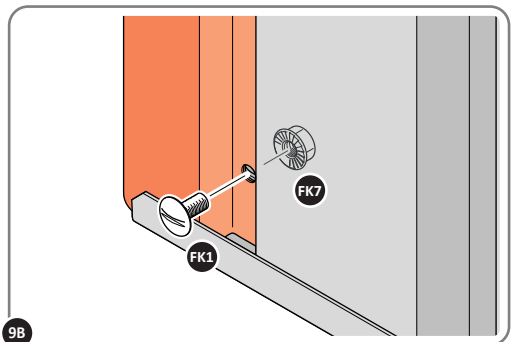

9B LOOSELY ATTACH CORNER POST AT LOCATION INDICATED ONLY.

ASSEMBLY STAGE 10

LOCATE SIDE WALL PANEL 0204-08 (824mm WIDE), PLEASE NOTE THE PANEL DOES NOT HAVE A SPECIFIC TOP OR BOTTOM SO CAN BE LOCATED EITHER WAY.

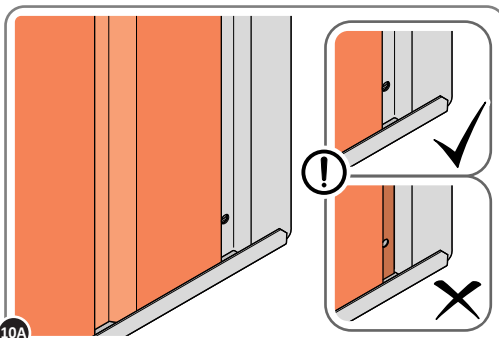
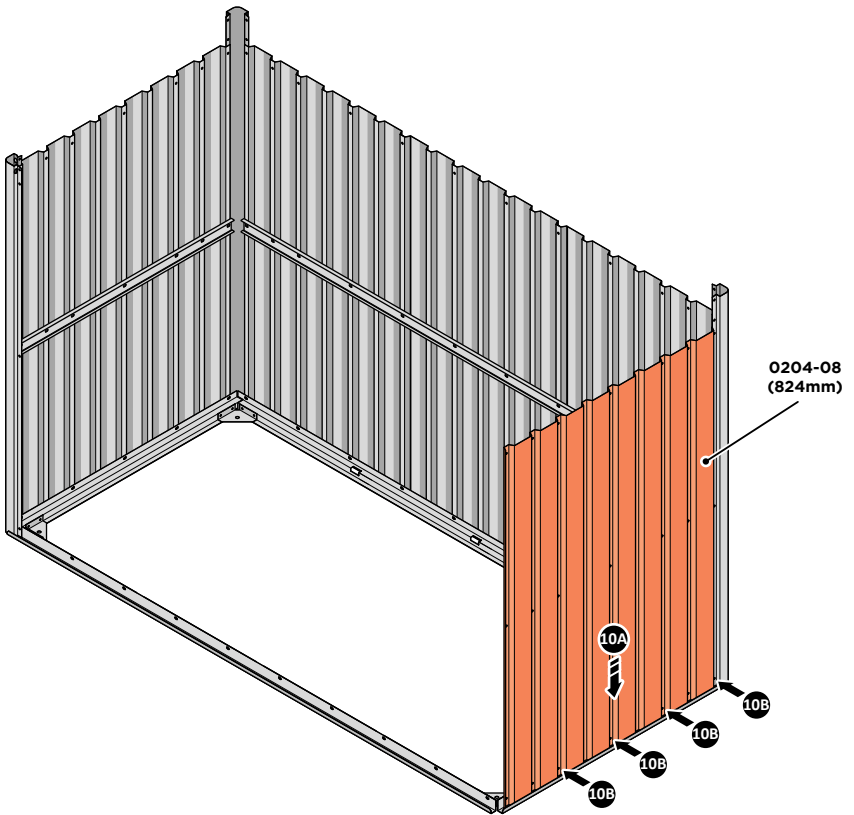

LOCATE SIDE WALL PANEL 0204-08 INTO POSITION AS SHOWN ABOVE.
IMPORTANT: ENSURE PANEL IS IN THE CORRECT ORIENTATION.

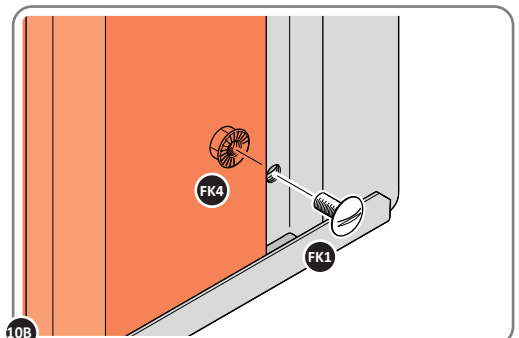

LOOSELY ATTACH SIDE WALL PANEL ONTO FLOOR RAIL AT x3 LOCATIONS INDICATED.
IMPORTANT: DO NOT SECURE AT OUTER FIXING POINTS AT THIS STAGE.

ASSEMBLY STAGE 11

LOCATE AND LOOSELY ATTACH SHORT CENTRE BRACE 0204-06 ONTO SIDE WALL.

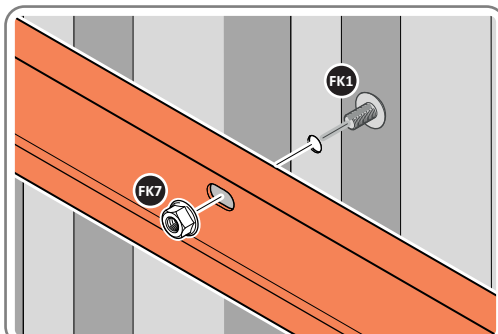
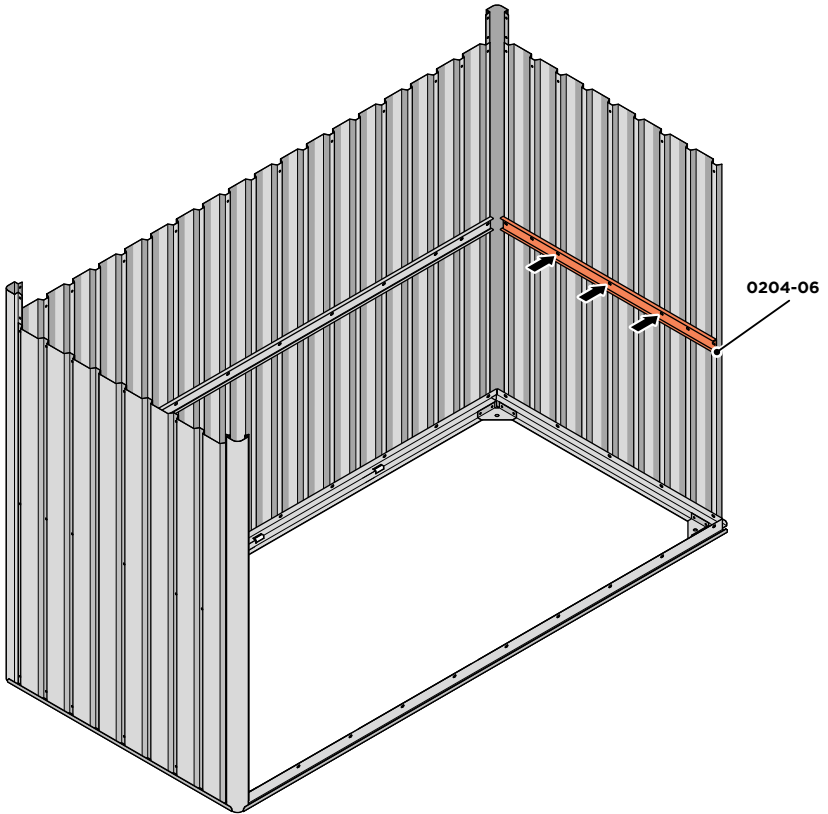

LOCATE AND LOOSELY ATTACH SHORT CENTRE BRACE 0204-06 AS SHOWN AT x3 LOCATIONS INDICATED ABOVE.

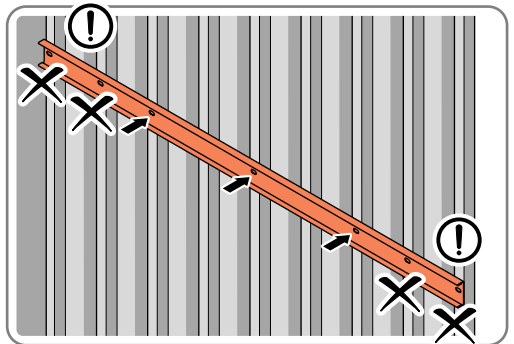

LOOSELY ATTACH AT x3 LOCATIONS INDICATED ONLY.
IMPORTANT: ONLY ATTACH AT FIXING POINTS INDICATED AT THIS STAGE.

ASSEMBLY STAGE 12

LOCATE AND LOOSELY ATTACH CORNER POST 0204-10 (1237mm) ONTO SIDE WALL.



0204-10 (1237mm LONG)
x2 HOLES & LARGE OBOURND AT TOP

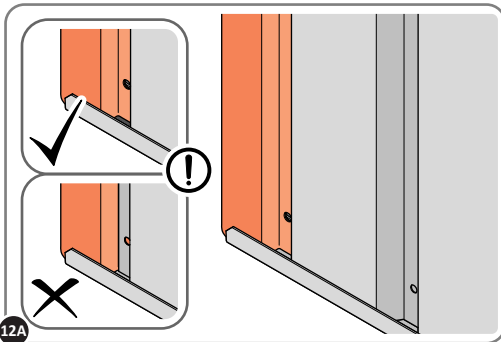
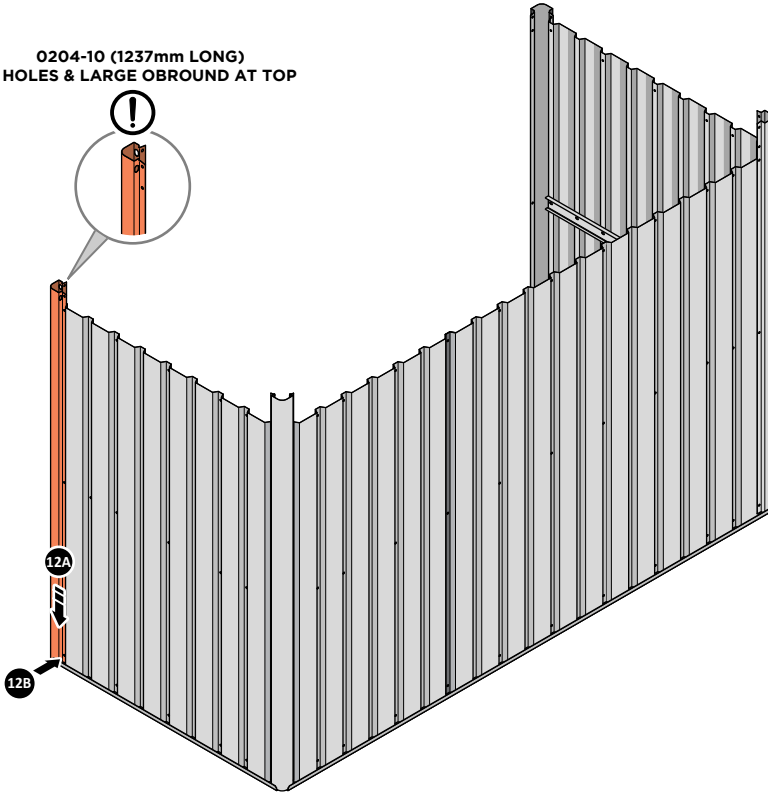

12A LOCATE CORNER POST 0204-10 (1237mm) AS SHOWN ABOVE.

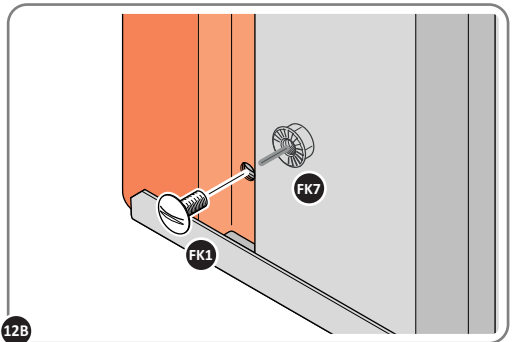

12B LOOSELY ATTACH CORNER POST AT LOCATION INDICATED ONLY.

ASSEMBLY STAGE 13

LOCATE AND LOOSELY ATTACH A CENTRE BRACE REAR BRACKET 0204-33.

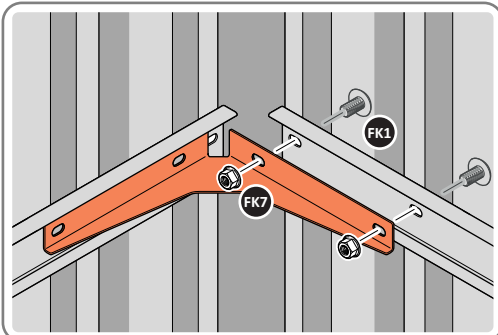
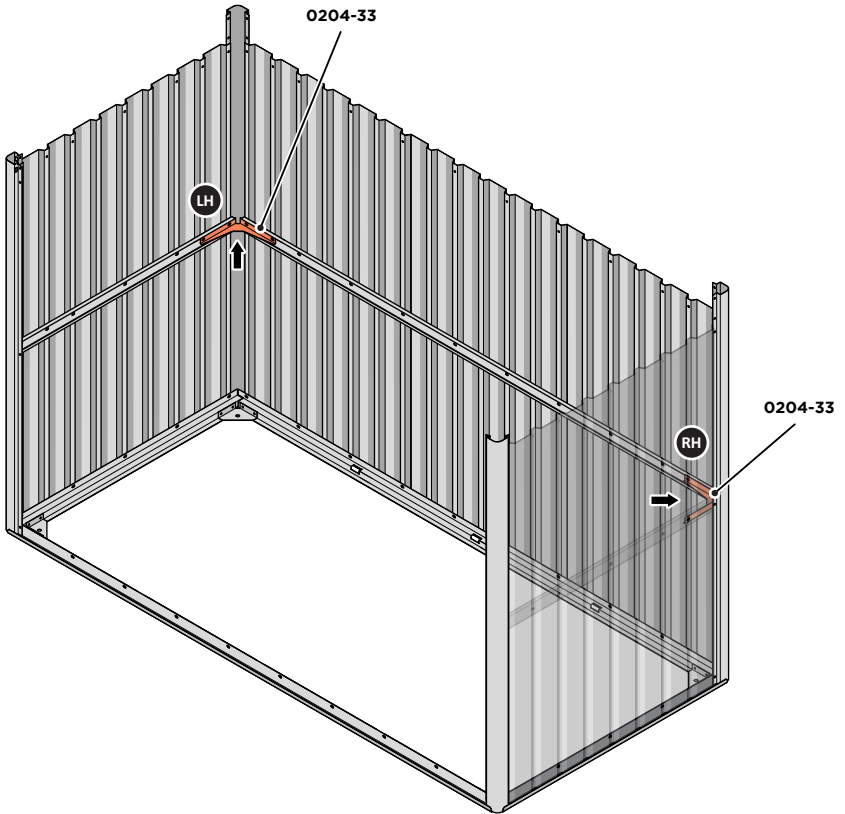

LOCATE AND LOOSELY ATTACH CENTRE BRACE CORNER BRACKET 0204-33 AS SHOWN ABOVE.

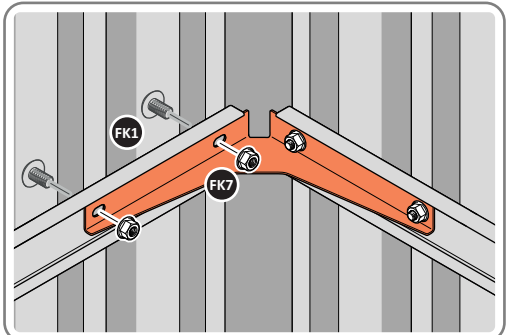

LOOSELY ATTACH CENTRE BRACE CORNER BRACKET 0204-33 AT REMAINING FIXING POINTS AS SHOWN.

Assembly Guide

ASSEMBLY STAGE 14

LOCATE AND LOOSELY ATTACH RIGHT-HAND TOP RAIL 0204-15.

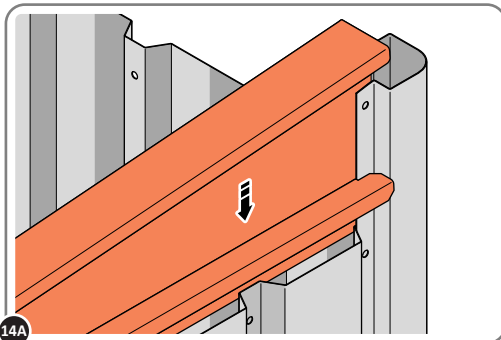
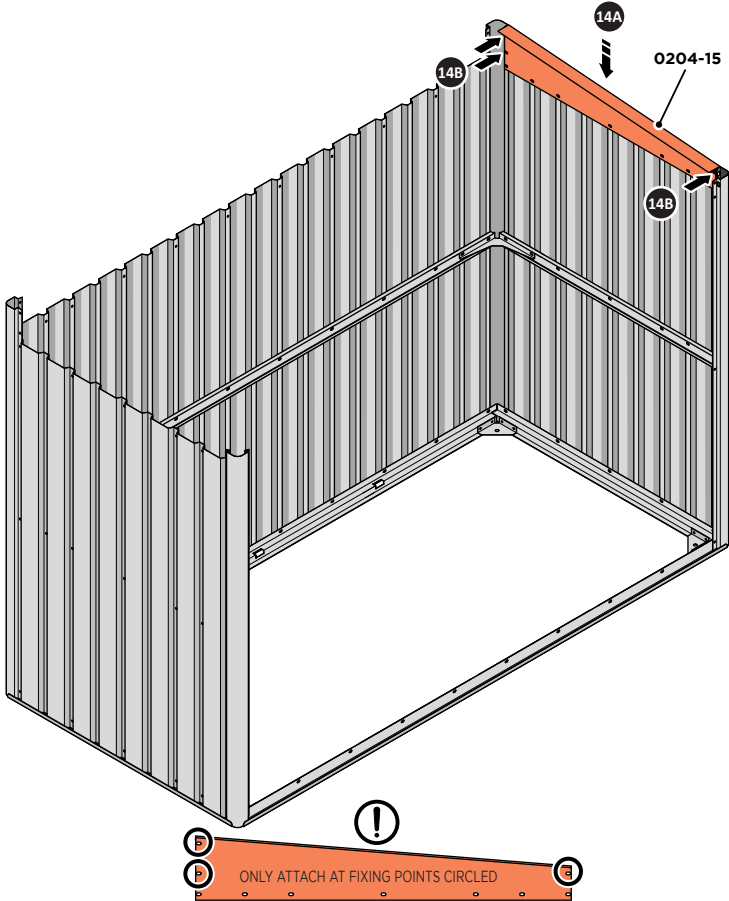

14A SLOT RIGHT-HAND TOP RAIL 0204-15 INTO POSITION AS SHOWN ABOVE.

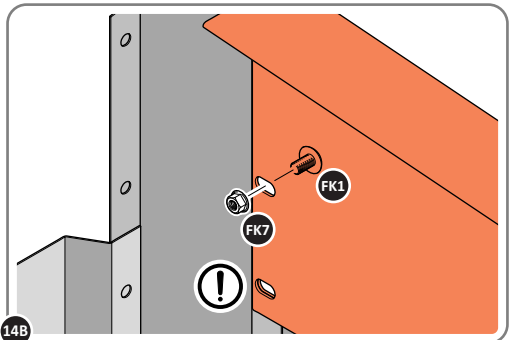

14B LOOSELY ATTACH AT x3 LOCATIONS INDICATED.
IMPORTANT: ONLY ATTACH AT FIXING POINTS INDICATED AT THIS STAGE.

ASSEMBLY STAGE 15

LOCATE AND LOOSELY ATTACH LEFT-HAND TOP RAIL 0204-19.

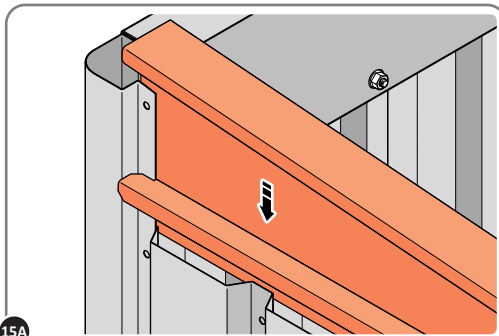
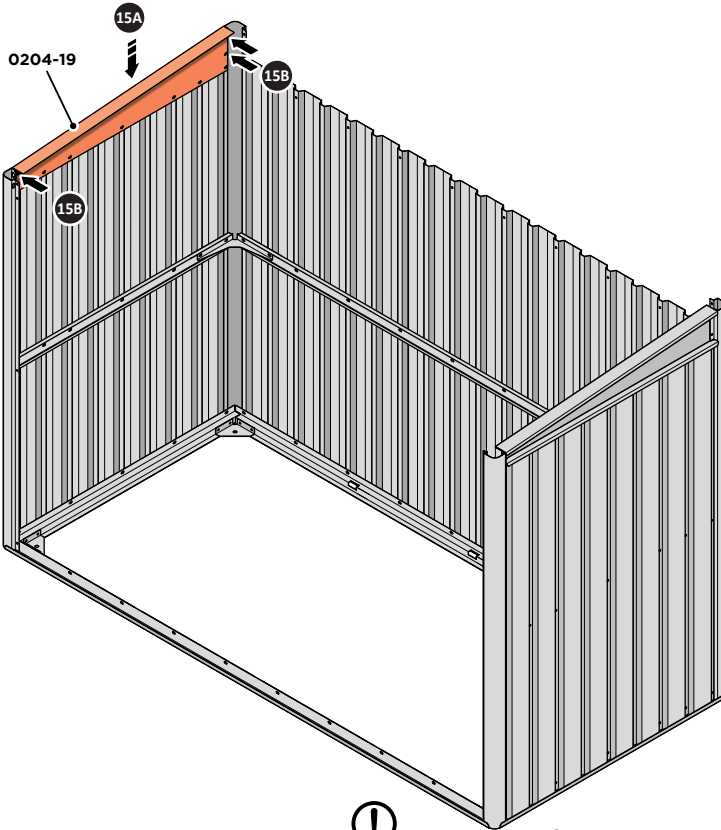

15A

SLOT LEFT-HAND TOP RAIL 0204-19 INTO POSITION AS SHOWN ABOVE.

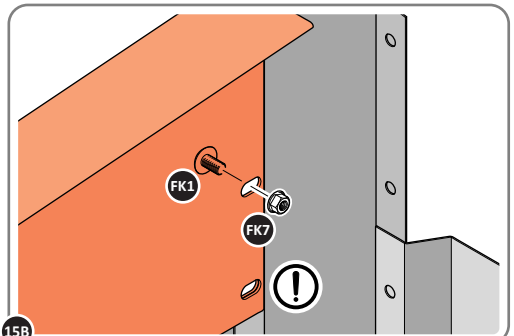

15B

LOOSELY ATTACH AT x3 LOCATIONS INDICATED.

IMPORTANT: ONLY ATTACH AT FIXING POINTS INDICATED AT THIS STAGE.

Assembly Guide

ASSEMBLY STAGE 16

LOCATE AND LOOSELY ATTACH REAR TOP RAIL 0204-18.

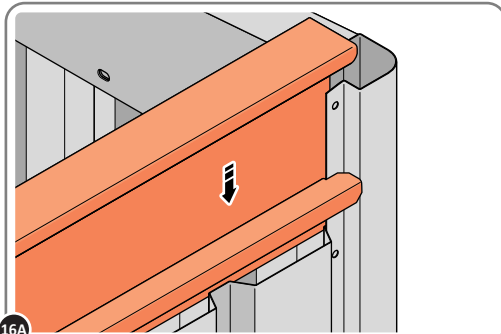
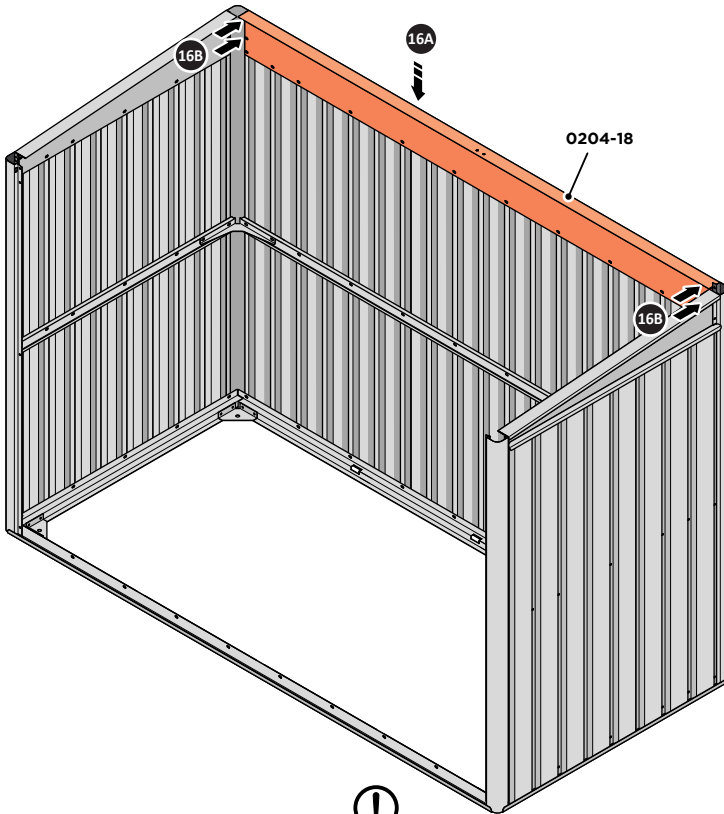

16A SLOT REAR TOP RAIL 0204-18 INTO POSITION AS SHOWN ABOVE.

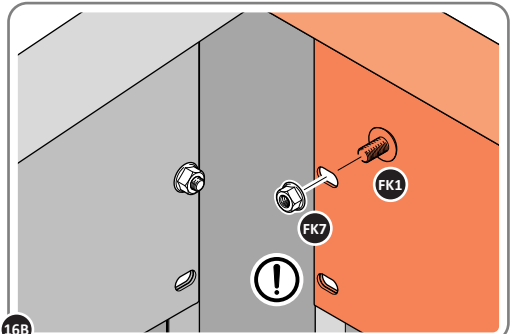

16B LOOSELY ATTACH AT x4 LOCATIONS INDICATED.
IMPORTANT: ONLY ATTACH AT FIXING POINTS INDICATED AT THIS STAGE.

Assembly Guide

ASSEMBLY STAGE 17

LOCATE AND LOOSELY ATTACH LEFT-HAND DOOR POST 0204-13.

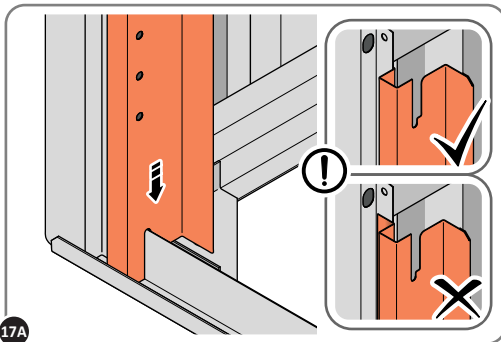
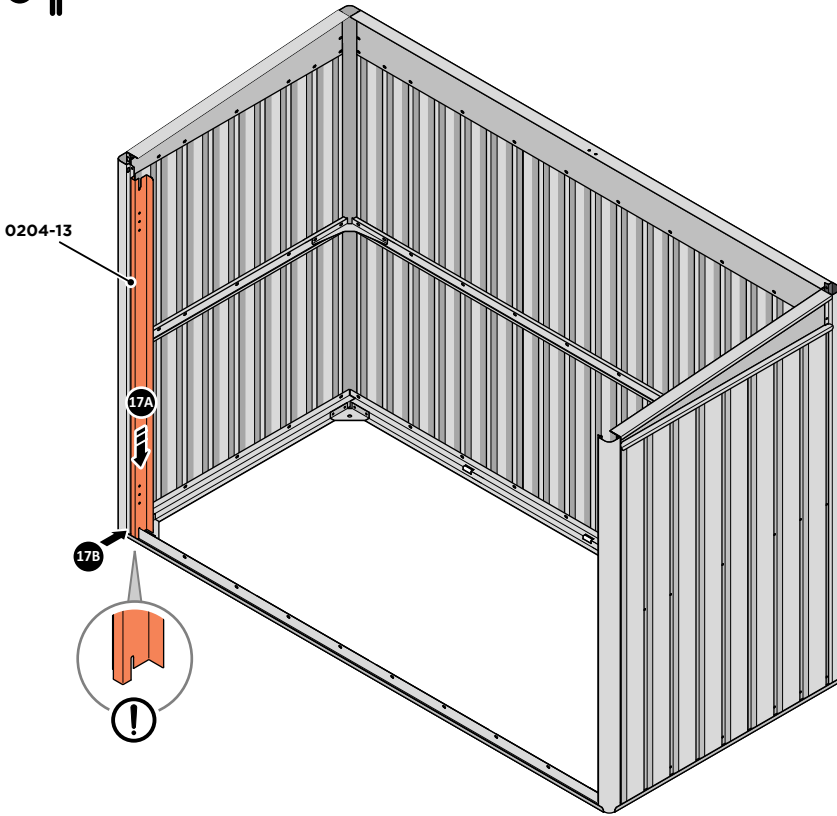

17A LOCATE LEFT-HAND DOOR POST 0204-13 AS SHOWN ABOVE.

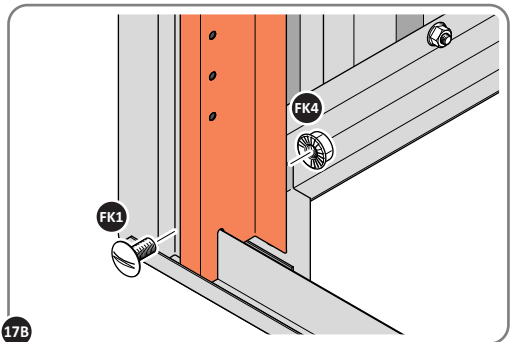

17B SECURE DOOR POST AT x1 LOCATION INDICATED.
IMPORTANT: ONLY ATTACH AT FIXING POINT INDICATED AT THIS STAGE.

ASSEMBLY STAGE 18

LOCATE AND LOOSELY ATTACH RIGHT-HAND DOOR POST 0204-15.

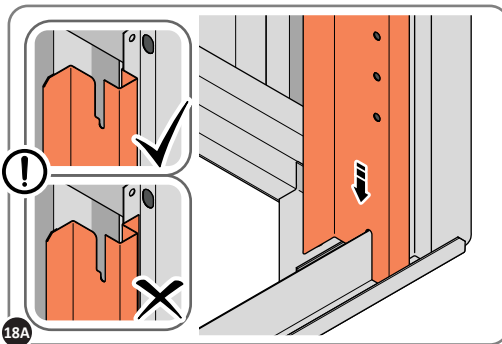
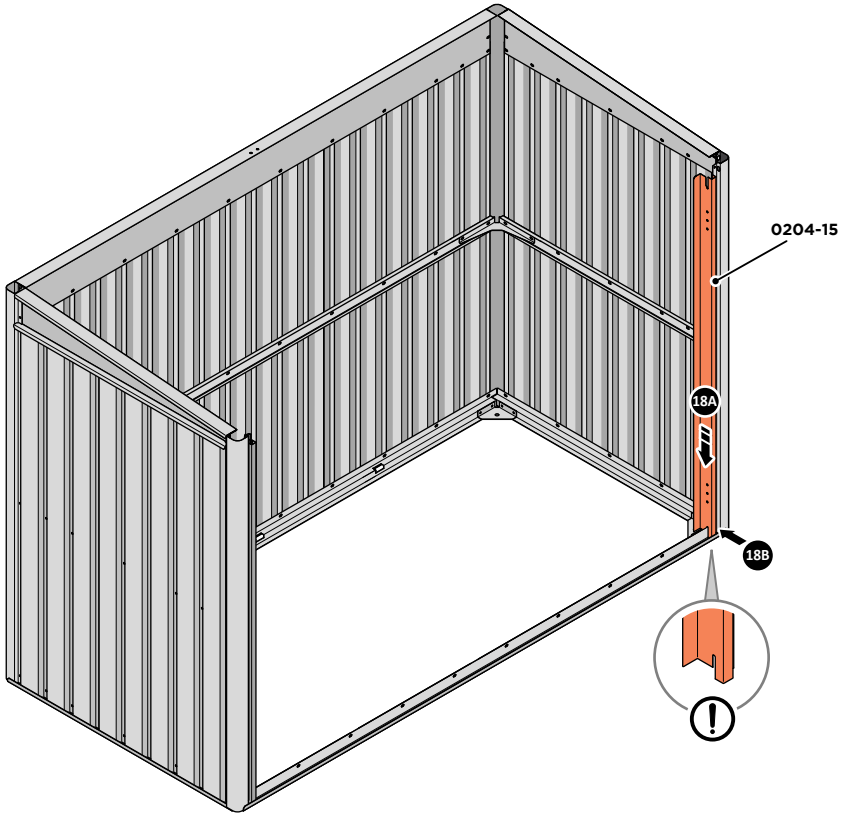

18A LOCATE RIGHT-HAND DOOR POST 0204-15 AS SHOWN ABOVE.

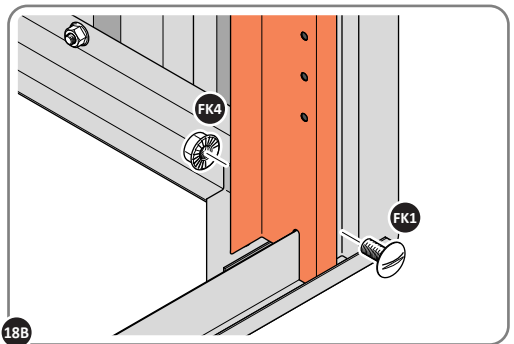

18B SECURE DOOR POST AT x1 LOCATION INDICATED.
IMPORTANT: ONLY ATTACH AT FIXING POINT INDICATED AT THIS STAGE.

ASSEMBLY STAGE 19

LOCATE AND LOOSELY ATTACH FRONT TOP RAIL 0204-14.

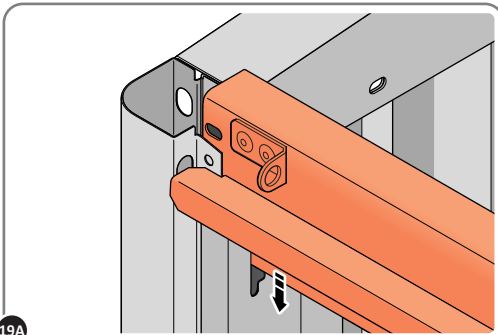
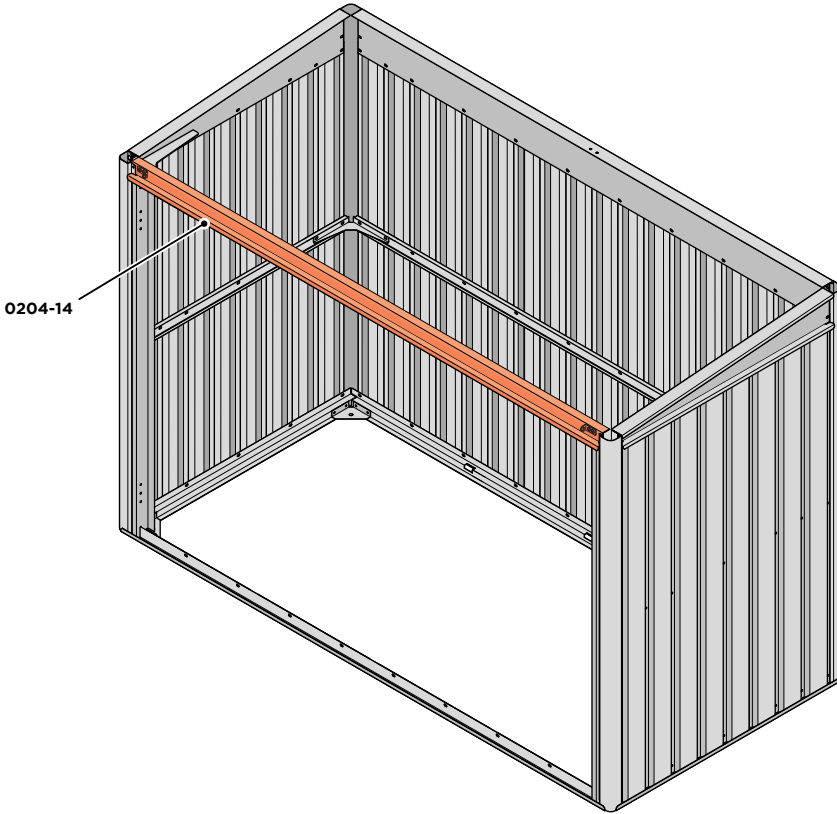

SLOT FRONT TOP RAIL 0204-14 INTO POSITION AS SHOWN ABOVE.

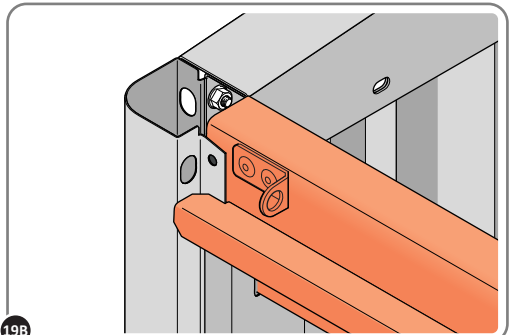

SECURE FRONT TOP RAIL AT X2 LOCATIONS INDICATED.

ASSEMBLY STAGE 20

LOCATE AND LOOSELY ATTACH x1 CENTRE BRACE FRONT BRACKET 0204-34 AT THE LOCATION INDICATED.

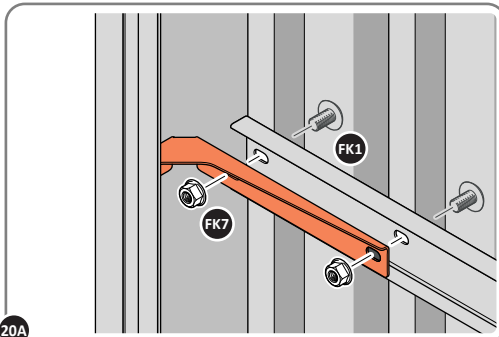
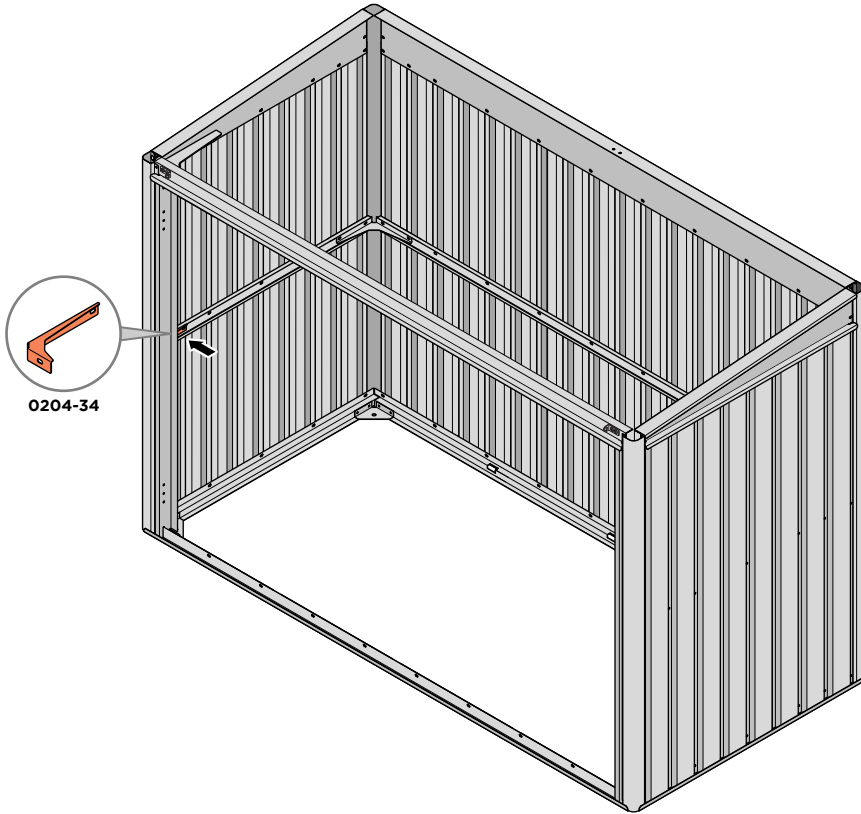

20A

LOOSELY ATTACH CENTRE BRACE FRONT BRACKET 0204-34 AS SHOWN ABOVE.

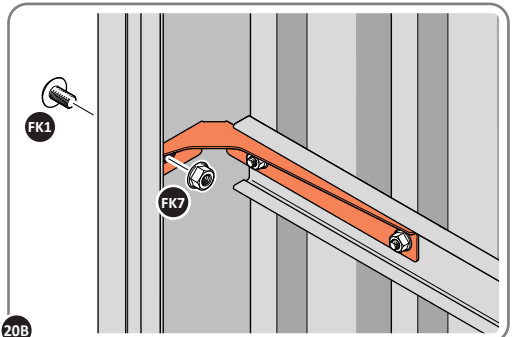

20B

LOOSELY ATTACH AT REMAINING FIXING POINT AS SHOWN.

Assembly Guide

ASSEMBLY STAGE 21

LOCATE AND LOOSELY ATTACH x1 CENTRE BRACE FRONT BRACKET 0204-34 AT THE LOCATION INDICATED.

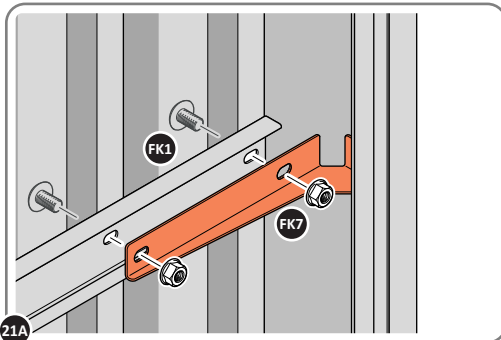
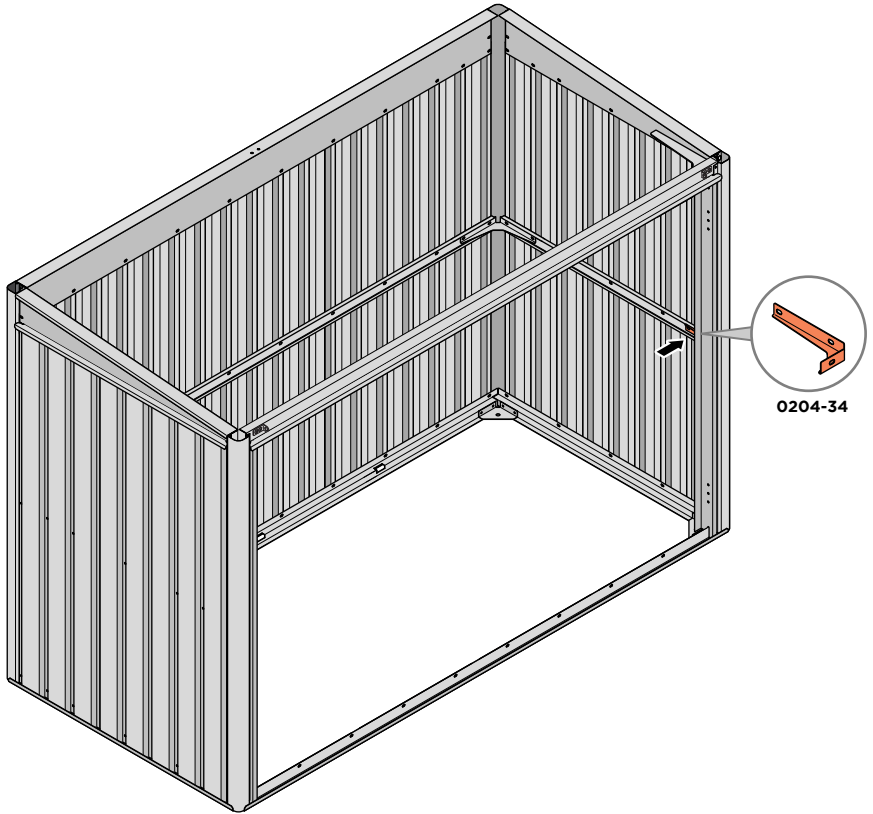

21A

LOOSELY ATTACH CENTRE BRACE FRONT BRACKET 0204-34 AS SHOWN ABOVE.

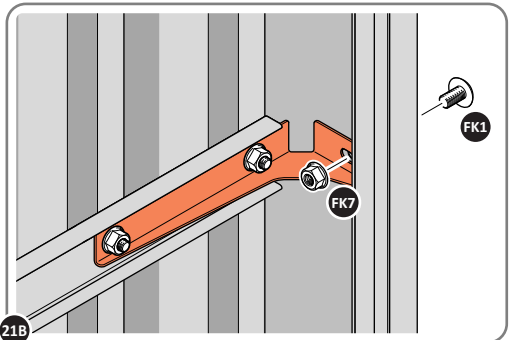

21B

LOOSELY ATTACH AT REMAINING FIXING POINT AS SHOWN.

ASSEMBLY STAGE 22

LOCATE AND LOOSELY ATTACH A TOP FRONT SUPPORT BRACKET 0204-59 AT EACH LOCATION INDICATED.

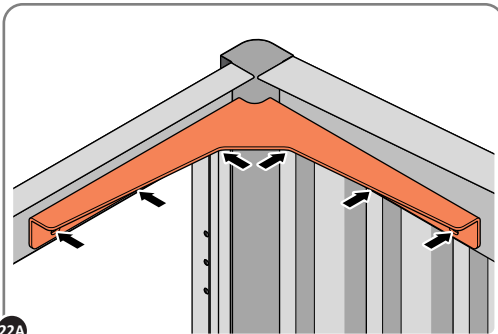
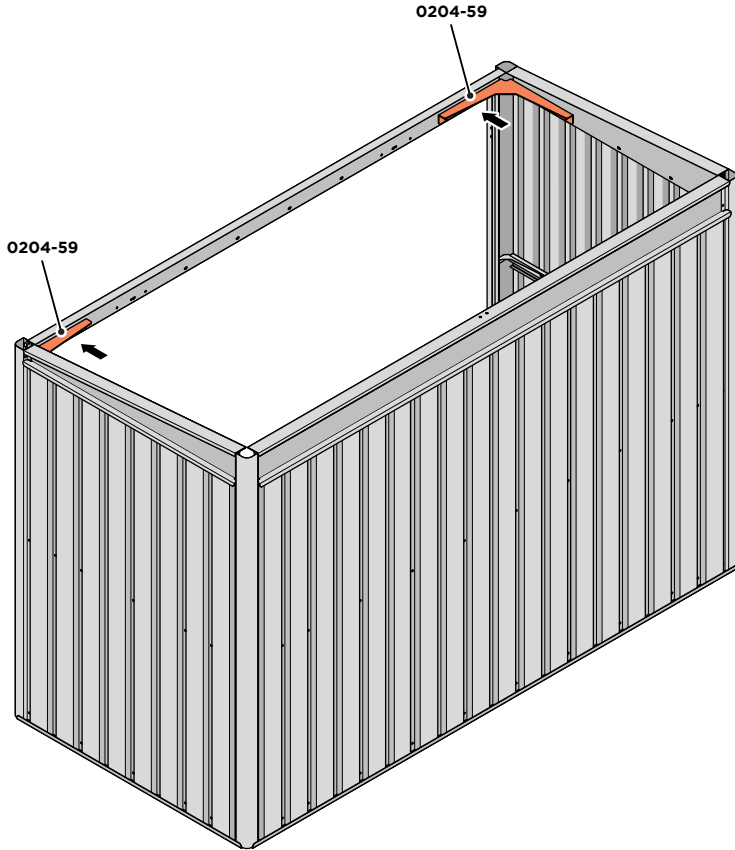

22A

LOCATE AND LOOSELY ATTACH EACH TOP FRONT SUPPORT BRACKET AS SHOWN USING THE TYPICAL FIXING METHOD SHOWN.

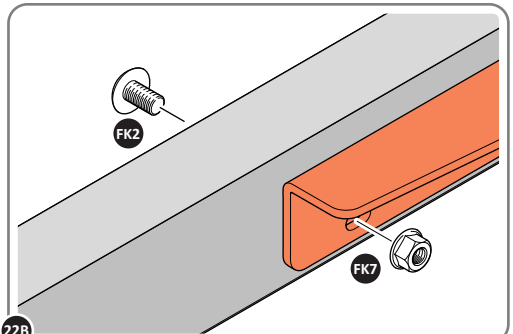

22B

LOOSELY ATTACH AT EACH FIXING POINT USING TYPICAL FIXING METHOD ABOVE.

Assembly Guide

ASSEMBLY STAGE 23

ASSEMBLE HINGE BRACKET ASSEMBLIES.

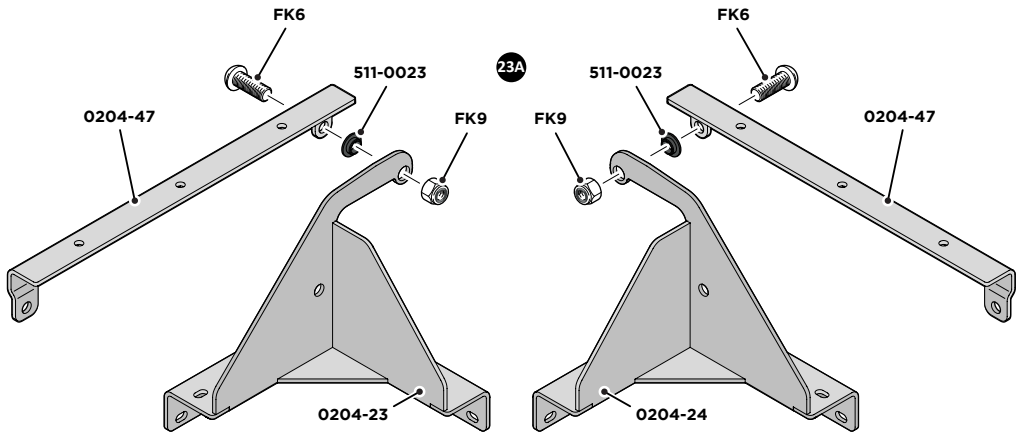

23A

23B

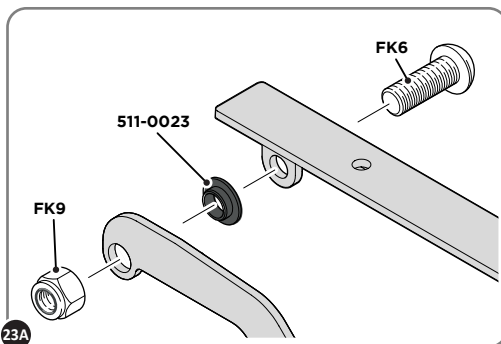
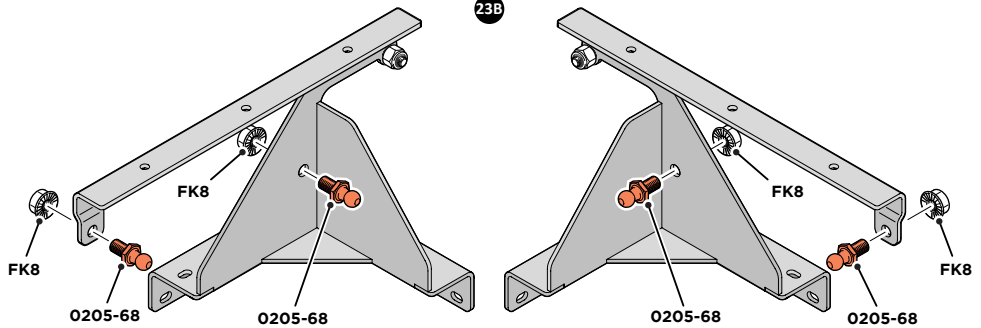

23A

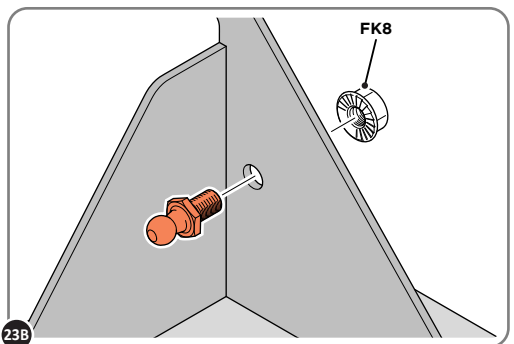

23B

SECURE HINGE BRACKET PIVOTS 0204-47 & 0204-50 ONTO EACH HINGE BRACKET BASE 0204-23 & 0204-24 AS SHOWN.

SECURE BALL STUDS 0205-68 ONTO EACH HINGE BRACKET PIVOT AND HINGE BRACKET BASE AS SHOWN.

Assembly Guide

ASSEMBLY STAGE 24

LOCATE AND LOOSELY ATTACH HINGE BRACKET ASSEMBLIES AT EACH LOCATION INDICATED.

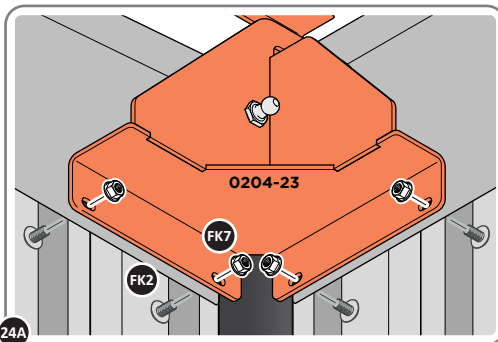
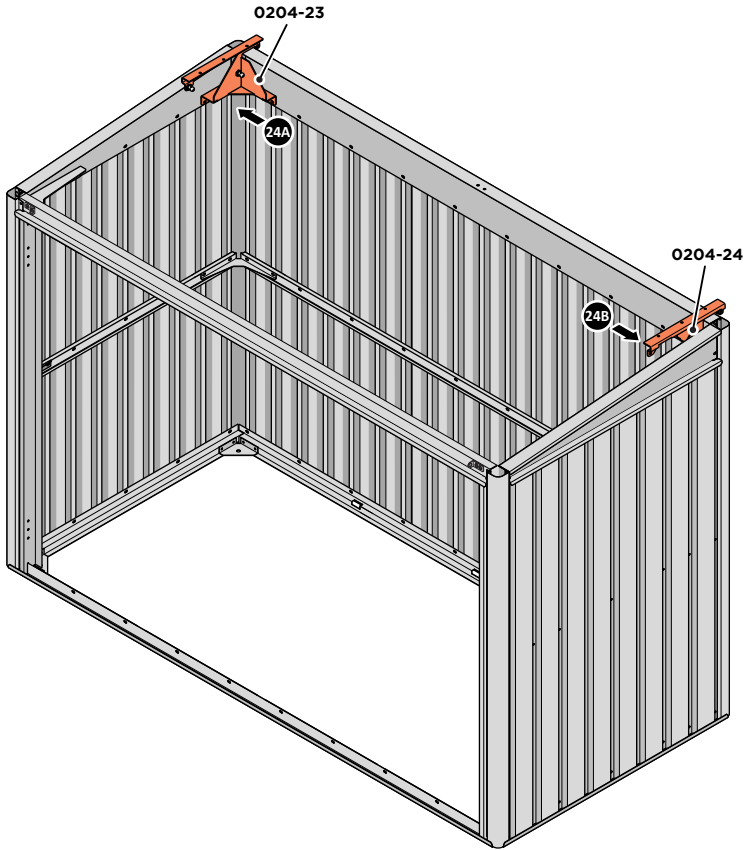

LOCATE AND LOOSELY ATTACH HINGE BRACKET ASSEMBLY ON RIGHT-HAND SIDE OF STORAGE UNIT AS SHOWN.

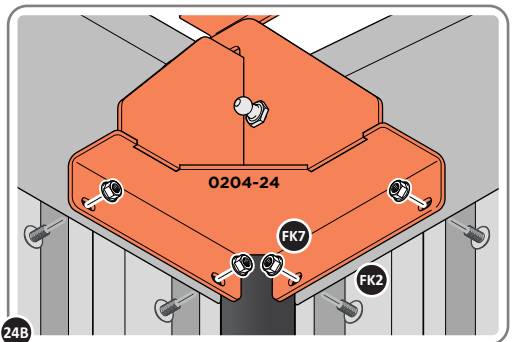

LOCATE AND LOOSELY ATTACH HINGE BRACKET ASSEMBLY ON LEFT-HAND SIDE OF STORAGE UNIT AS SHOWN.

ASSEMBLY STAGE 25

LOOSELY ATTACH AT ALL UPPER FIXING POINTS INDICATED.

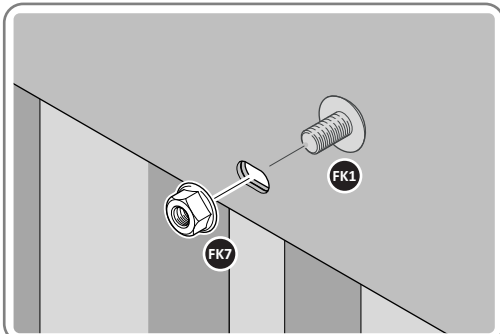
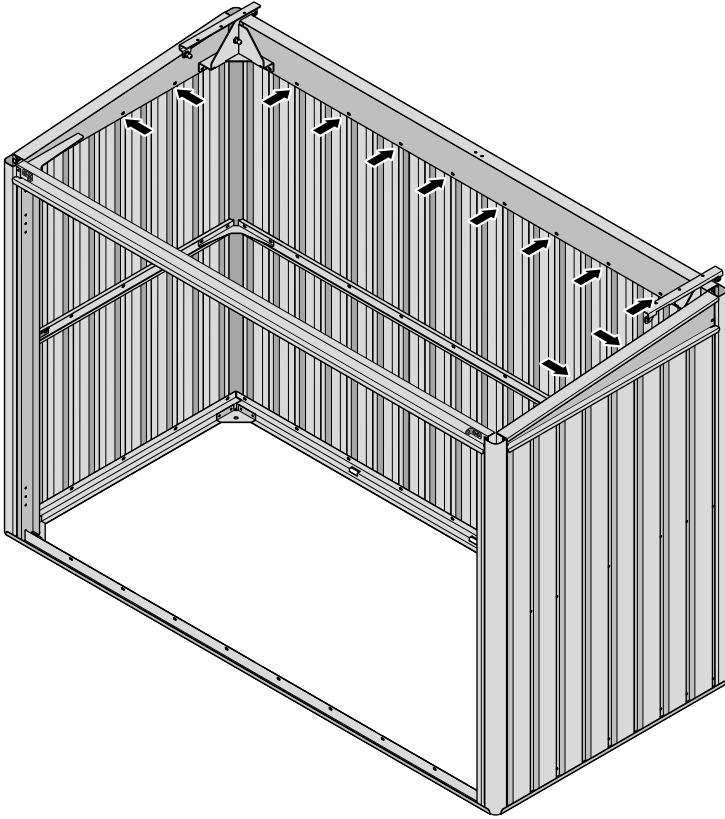

LOOSELY ATTACH AT x12 UPPER FIXING POINTS INDICATED AS SHOWN ABOVE.



IMPORTANT

ADJUST ALL COMPONENTS FOR BEST POSSIBLE FIT AND TIGHTEN ALL FASTENERS.

ONCE ALL FASTENERS HAVE BEEN CHECKED AND ARE SECURE PROCEED ONTO STAGE 26.

ONCE UPPER FIXING POINTS ARE ATTACH TIGHTEN ALL FASTENERS.

ASSEMBLY STAGE 26

INSERT AN END CAP 0204-30 AT EACH LOCATION INDICATED.

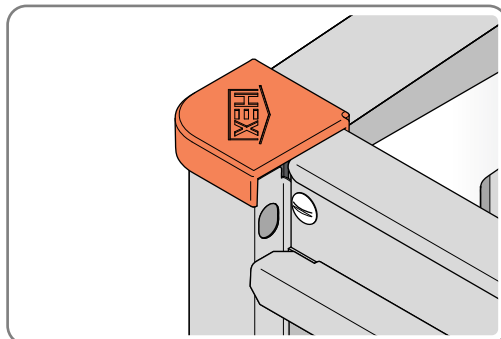
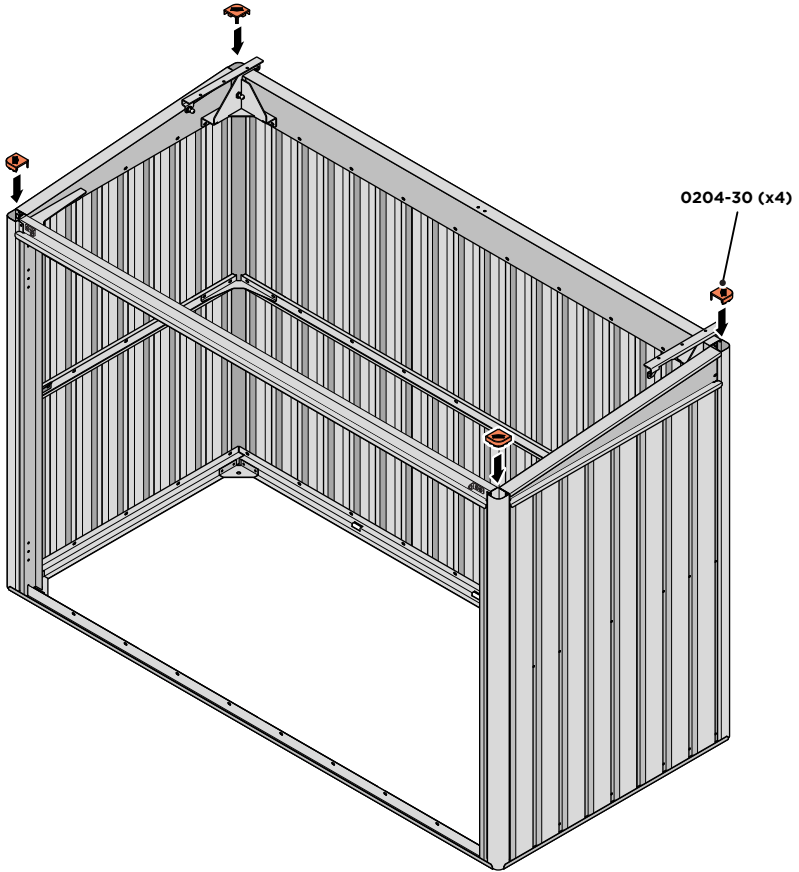

INSERT AN END CAP 0204-30 INTO EACH LOCATION INDICATED AS SHOWN.

ASSEMBLY STAGE 27

ASSEMBLE AND SECURE HINGE BRACKET BASE 0204-46 AND HINGE BRACKET PIVOT 0204-56.

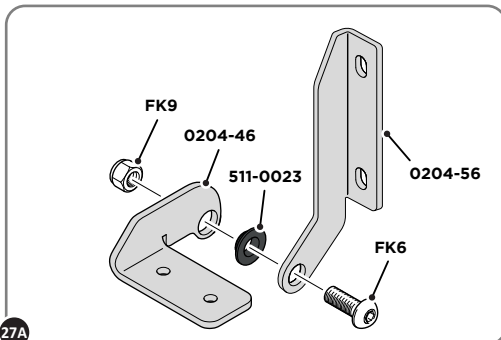
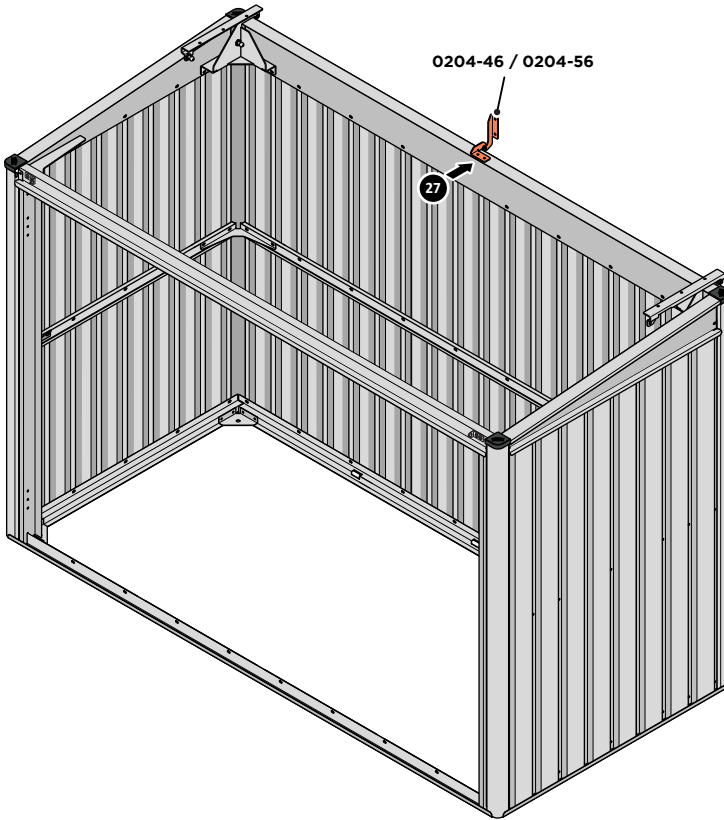

27A

ASSEMBLE HINGE BRACKET BASE 0204-46 AND HINGE BRACKET PIVOT 0204-56 AS SHOWN.

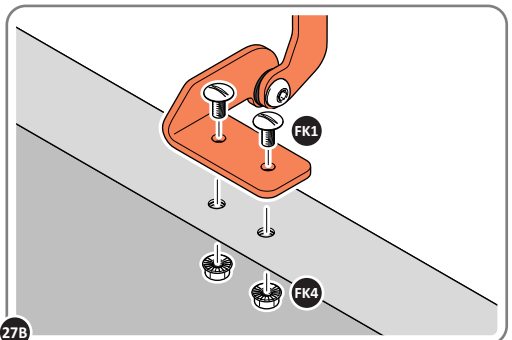

27B

SECURE HINGE BRACKET BASE 0204-46 ONTO STORAGE UNIT AS SHOWN.

ASSEMBLY STAGE 28

LOCATE AND SECURE DOOR STRIP 0204-71.

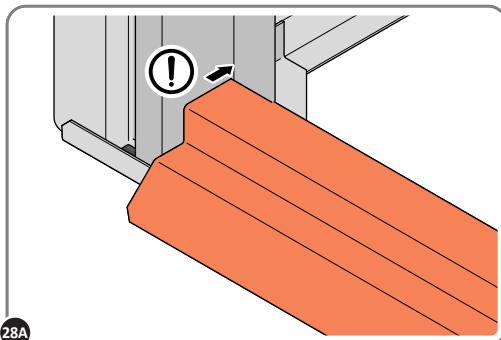
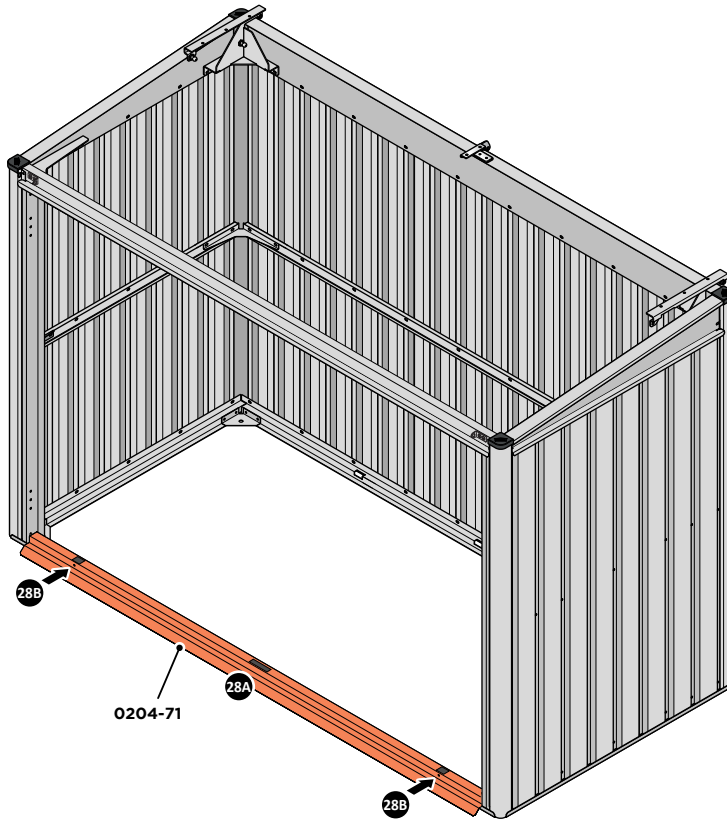

LOCATE DOOR STRIP 0204-71 AS SHOWN.
IMPORTANT: ENSURE DOOR STRIP IS PUSHED AGAINST DOOR POST RETURN.

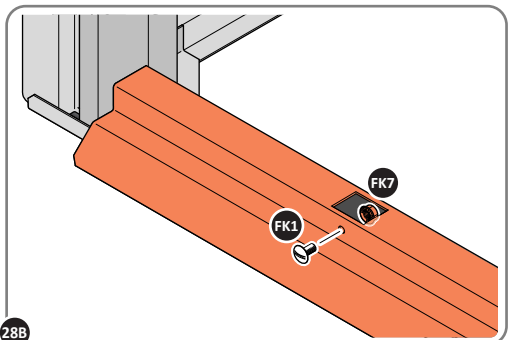

SECURE DOOR STRIP ONTO FLOOR PANELS AT x2 LOCATIONS INDICATED,
USE EXISTING HOLE AS A LOCATION GUIDE.

ASSEMBLY STAGE 29

LOCATE AND SECURE T-HANDLE 0204-58.

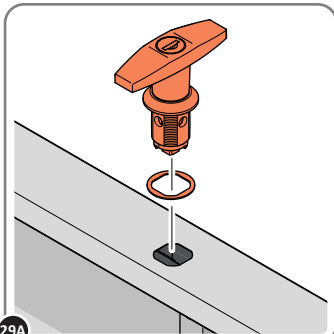
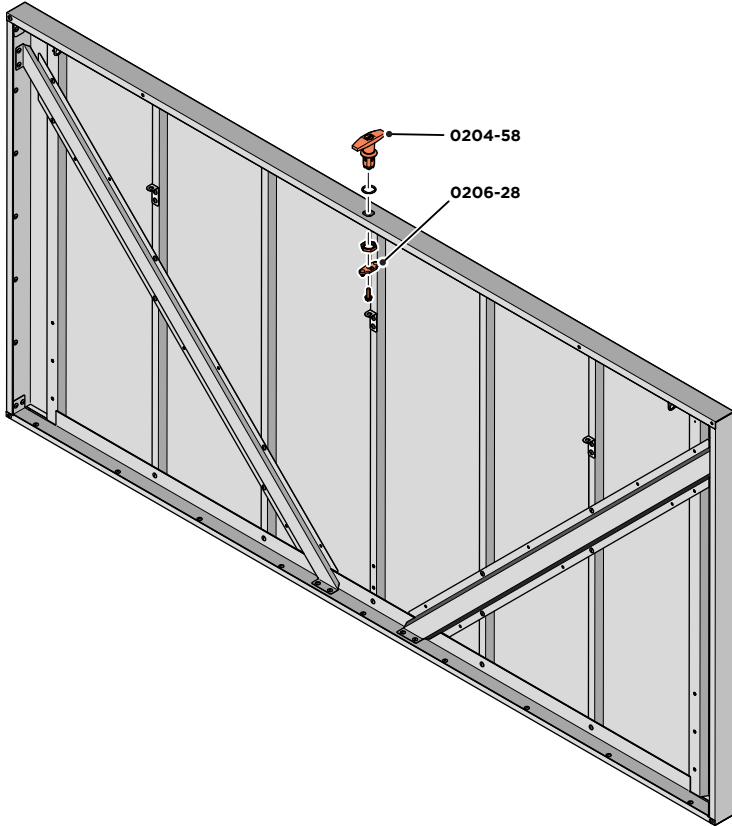

29A
LOCATE T-HANDLE AND T-HANDLE GASKET 0204-58 INTO LID 0204-17 APERTURE AS SHOWN.

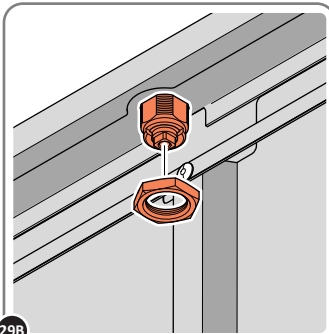

29B
SECURE T-HANDLE USING T-HANDLE ASSEMBLY NUT AS SHOWN.

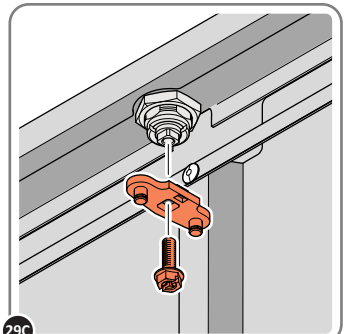

29C
SECURE 2 POINT CAM 0206-28 ONTO T-HANDLE USING BOLT SHOWN ABOVE FROM T-HANDLE ASSEMBLY.

ASSEMBLY STAGE 30

LOCATE A BUMPER STOP 0204-61 AND GUIDE BUSH 0204-51 AT EACH LOCATION INDICATED.

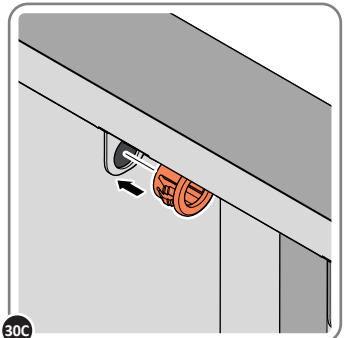
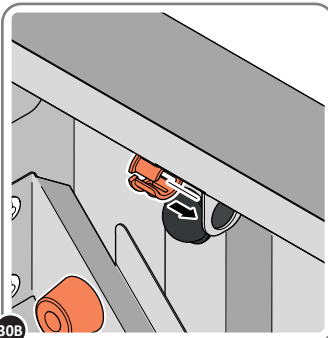
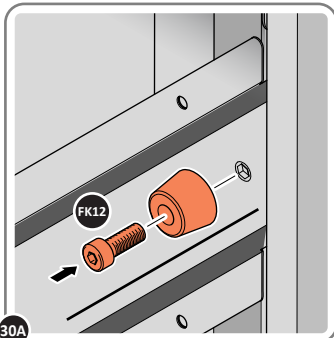
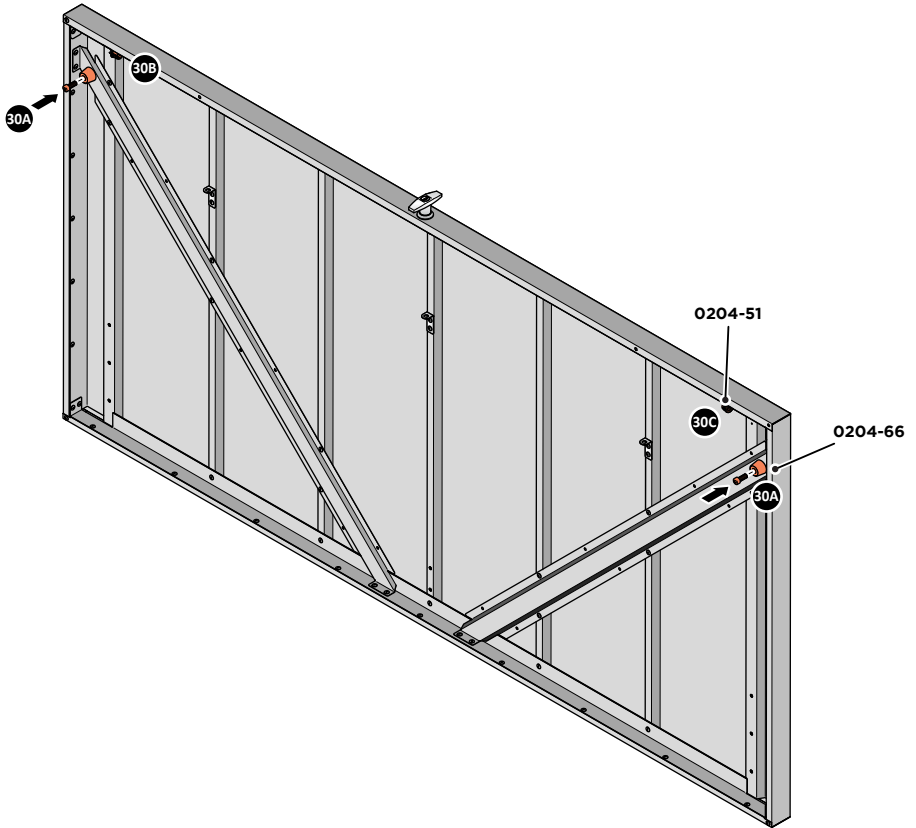

APPLY RUBBER FOOT 0204-66 ONTO LID AT LOCATIONS 30A AND 30B. LOCATE GUIDE BUSH 0204-51 INTO LID TAB AS SHOWN. LOCATE GUIDE BUSH 0204-51 INTO LID TAB AS SHOWN, SHOWN, USE EXISTING HOLE AS A LOCATION GUIDE.

Assembly Guide

ASSEMBLY STAGE 31

LOCATE AND SECURE RODS 0204-57 AT EACH LOCATION INDICATED.

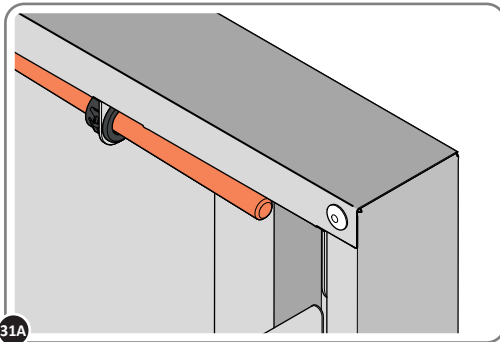
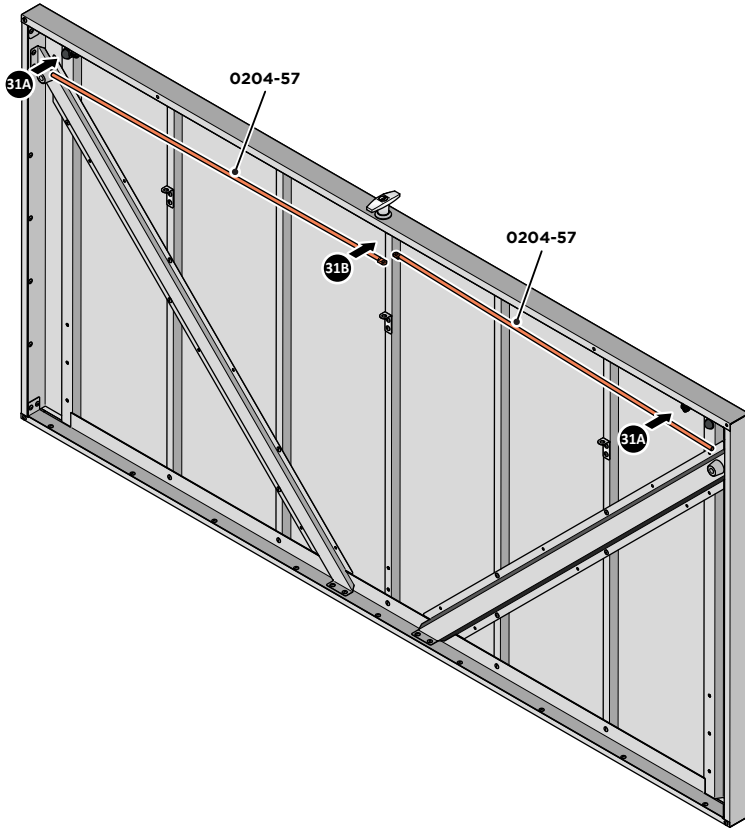

31A SLOT EACH ROD 0204-57 INTO POSITION AS SHOWN ABOVE.

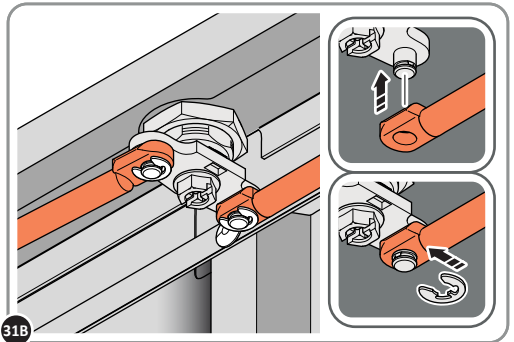

31B SECURE ROD ONTO 2 POINT CAM USING E-CLIPS (PART OF 0206-28 ASSEMBLY).

Assembly Guide

ASSEMBLY STAGE 32

ASSEMBLE BIN LID CLIP ASSEMBLIES AND ATTACH ONTO LID AT EACH LOCATION INDICATED.

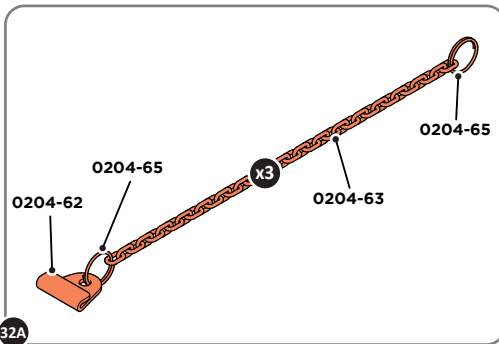
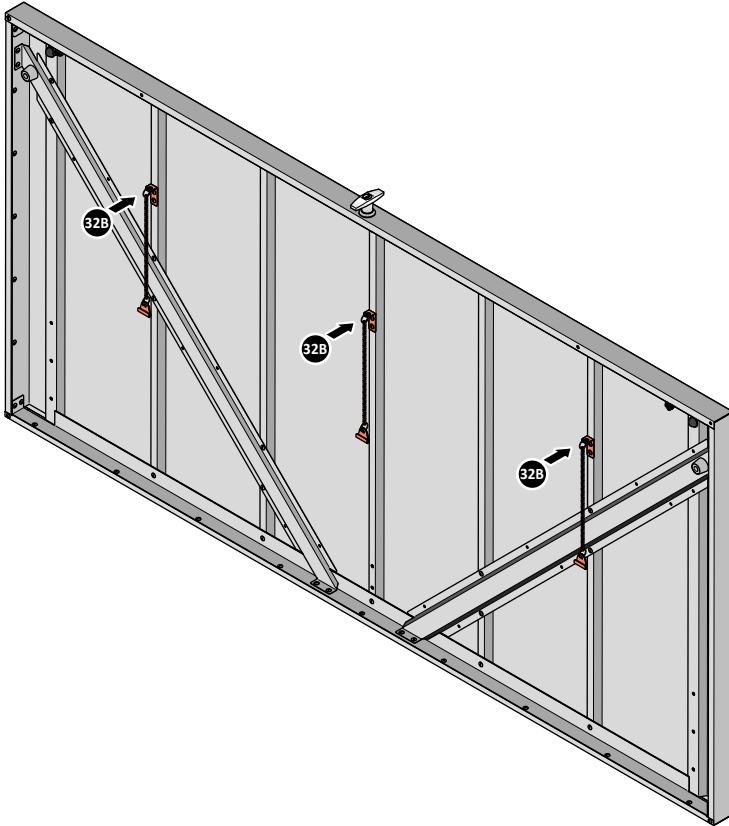

32A ASSEMBLE x3 BIN LID CLIP ASSEMBLIES AS SHOWN ABOVE.

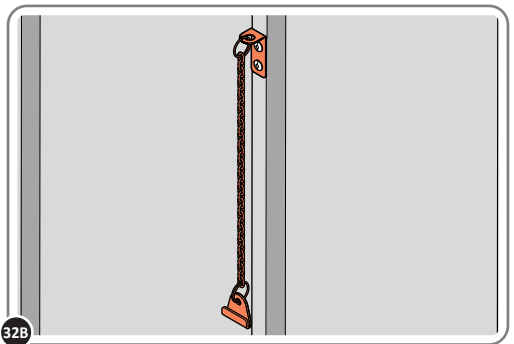

32B ATTACH BIN LID CLIP ASSEMBLIES ONTO LID AT EACH LOCATION INDICATED.

Assembly Guide

ASSEMBLY STAGE 33

LOCATE LID ONTO STORAGE UNIT AND SECURE HINGE BRACKET AT EACH LOCATION INDICATED.

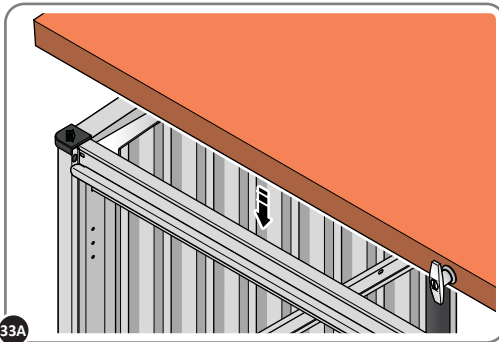
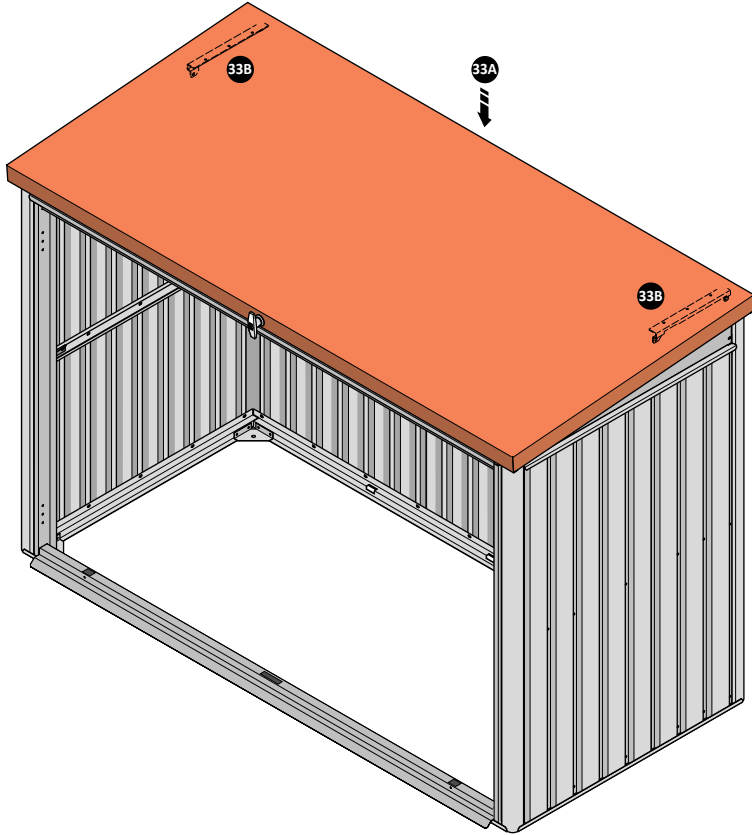

33A LOCATE LID ASSEMBLY ONTO STORAGE UNIT AS SHOWN.

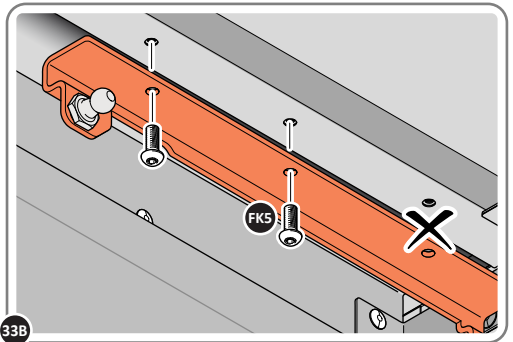

33B SECURE HINGE BRACKET ONTO LID ASSEMBLY, DO THIS WITH THE LID DOWN.
IMPORTANT: ONLY ATTACH AT FIXING POINTS INDICATED AT THIS STAGE.

ASSEMBLY STAGE 34

SECURE LID AT REMAINING HINGE FIXING POINTS.

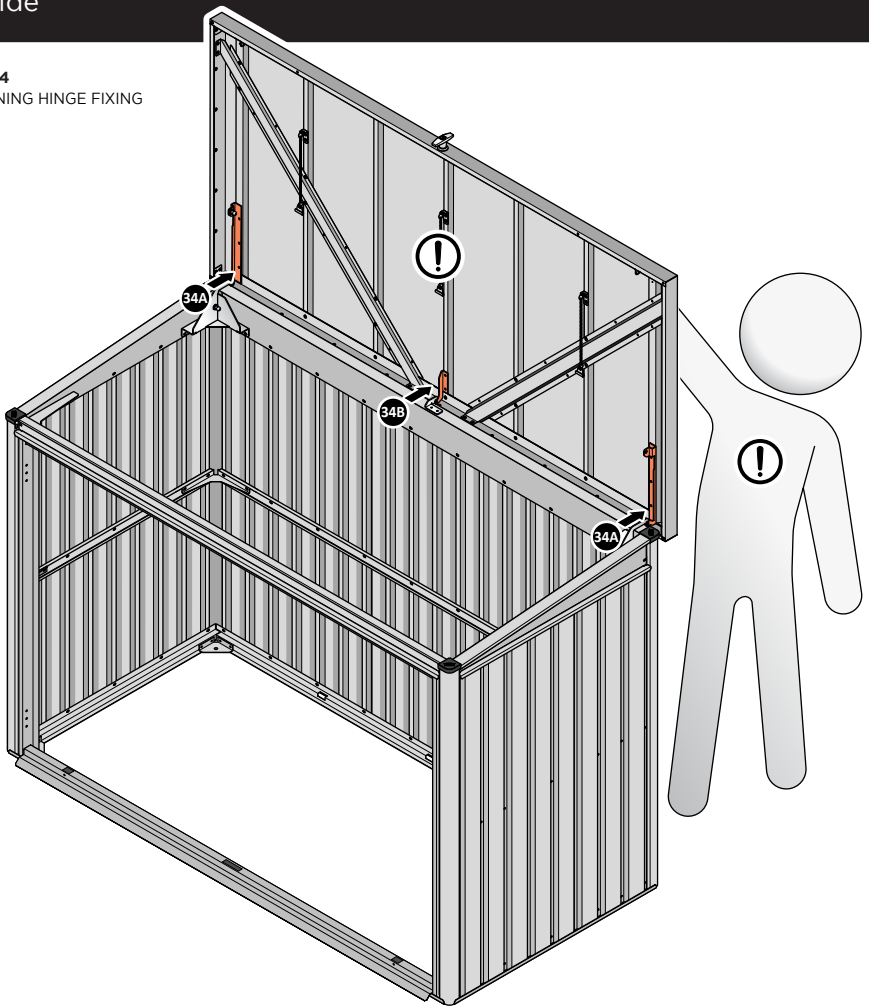

! IMPORTANT: ENSURE LID IS SUPPORTED BY ANOTHER PERSON WHILST CARRYING OUT THIS PROCEDURE **!**

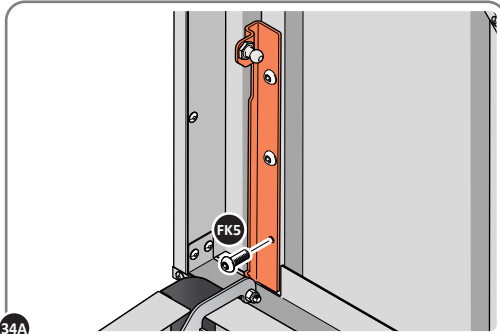

34A SECURE EACH HINGE BRACKET AT REMAINING FIXING AS SHOWN ABOVE.

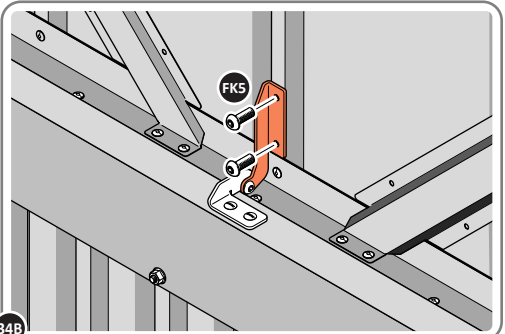

34B SECURE CENTRE HINGE BRACKET AS SHOWN ABOVE.

Assembly Guide

ASSEMBLY STAGE 35

LOCATE AND GAS STRUTS 0204-25 AT EACH LOCATION INDICATED.

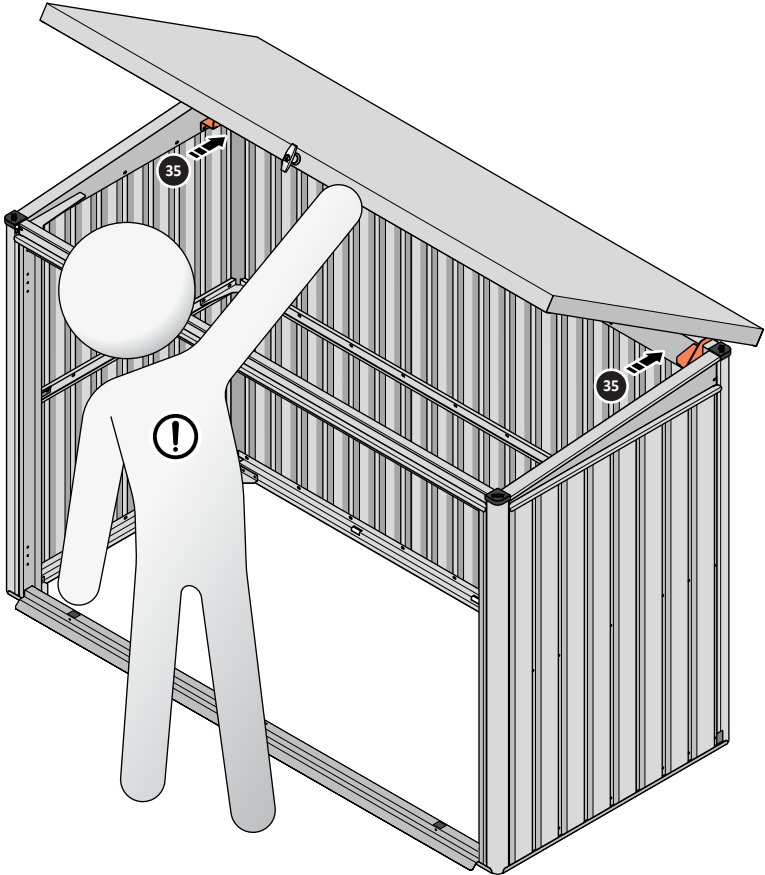

! IMPORTANT: ENSURE LID IS SUPPORTED BY ANOTHER PERSON WHILST CARRYING OUT THIS PROCEDURE **!**

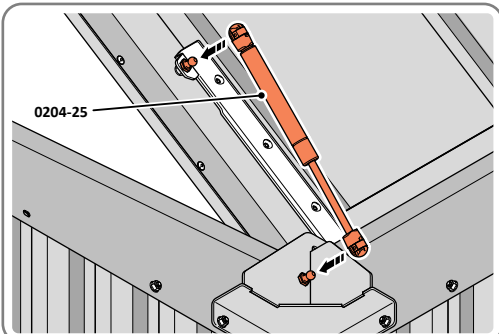

FIX GAS STRUT 0204-25 ONTO BALL STUDS LOCATED ON LEFT-HAND SIDE OF UNIT. IMPORTANT: ENSURE CORRECT GAS STRUT IS USED, THIS IS THE THICKER ONE.

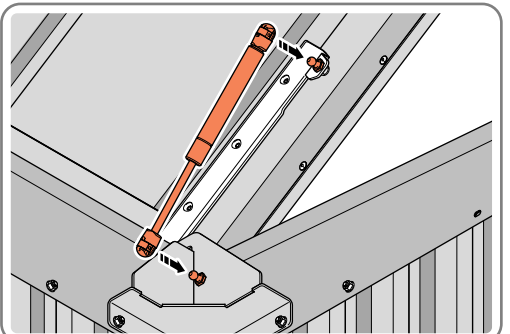

FIX GAS STRUT 0204-25 ONTO BALL STUDS LOCATED ON RIGHT-HAND SIDE OF UNIT. IMPORTANT: ENSURE CORRECT GAS STRUT IS USED, THIS IS THE THICKER ONE.

ASSEMBLY STAGE 36

LOCATE AND SECURE A CORNER BRACE 0204-03 AT EACH LOCATION INDICATED.

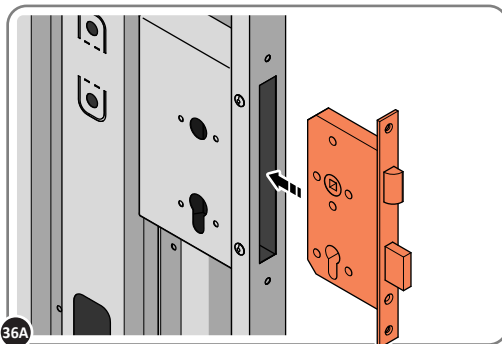
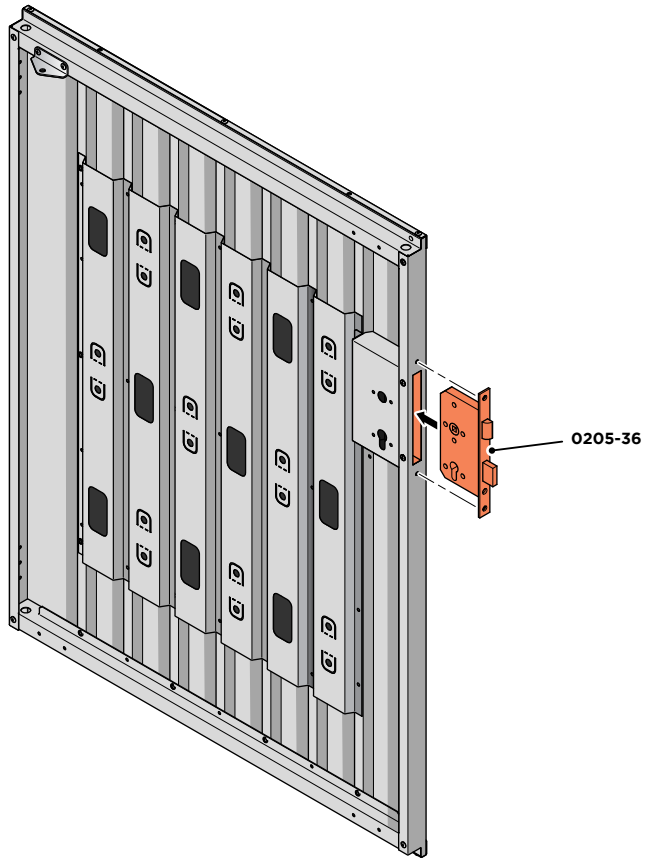

36A

LOCATE EURO MORTICE LOCK 0203-32 RIGHT-HAND DOOR APERTURE AS SHOWN.

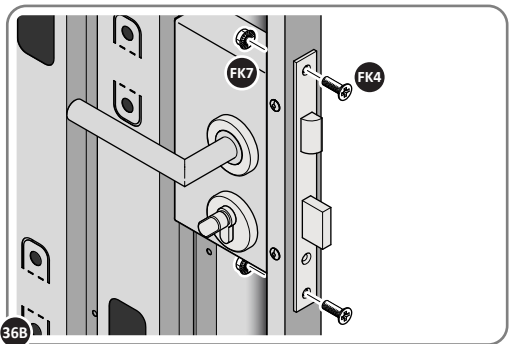

36B

SECURE EURO MORTICE LOCK 0203-32 AT X2 LOCATIONS INDICATED ABOVE.
SEE FOLLOWING DATA SHEET FOR COMPLETION OF MORTICE LOCK INSTALLATION.

ASSEMBLY STAGE 36 CONTINUED

LOCATE AND SECURE A CORNER BRACE 0204-03 AT EACH LOCATION INDICATED.

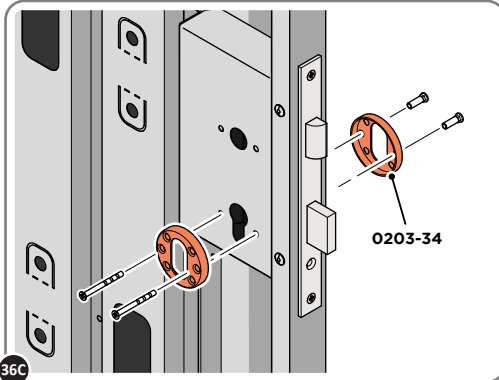

36C LOCATE AND SECURE EURO ESCUTCHEON 0203-34 AS SHOWN.

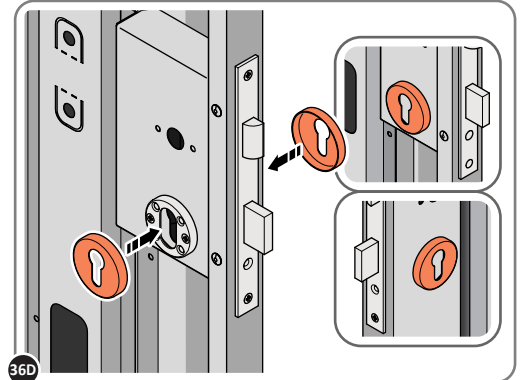

36D LOCATE EURO ESCUTCHEON COVER 0203-34 ONTO EURO ESCUTCHEON AS SHOWN.
PLEASE NOTE: THESE ARE PUSHED ON AND WILL CLICK INTO PLACE.

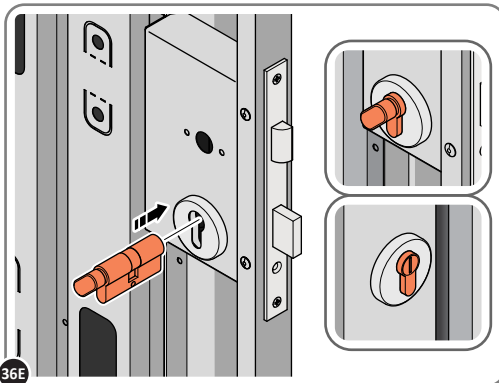

36E LOCATE EURO CYLINDER 0203-36 INTO DOOR APERTURE.
IMPORTANT: ENSURE COVER IS FITTED AS SHOWN.

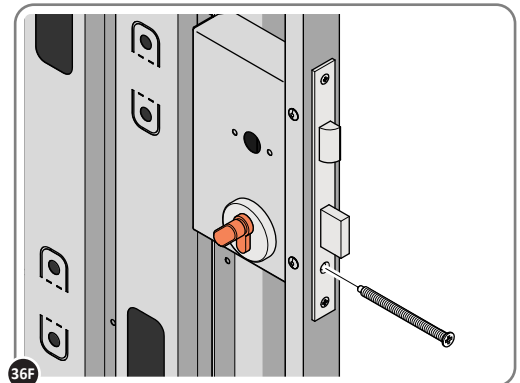

36F SECURE EURO CYLINDER 0203-36 AS SHOWN ABOVE.
PLEASE NOTE: FIXING IS PART OF THE EURO MORTICE LOCK ASSEMBLY.

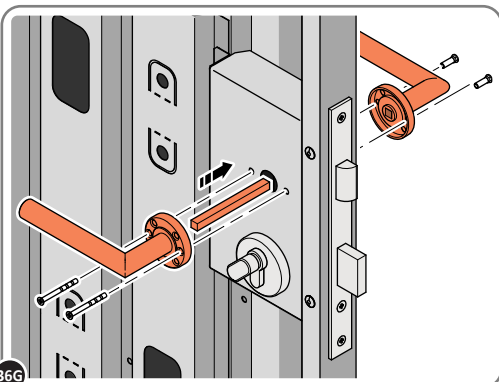

36G LOCATE AND SECURE DOOR HANDLE ASSEMBLY 0203-33 AS SHOWN.

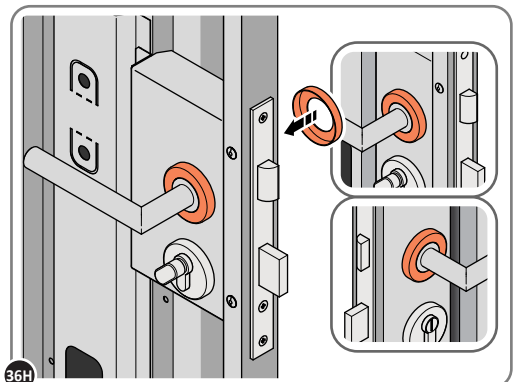

36H LOCATE COVER ONTO DOOR HANDLE AS SHOWN.
PLEASE NOTE: THESE ARE PUSHED ON AND WILL CLICK INTO PLACE.

ASSEMBLY STAGE 37

LOCATE AND SECURE A CORNER BRACE 0204-03 AT EACH LOCATION INDICATED.

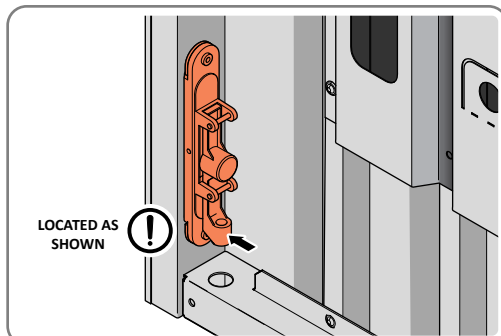
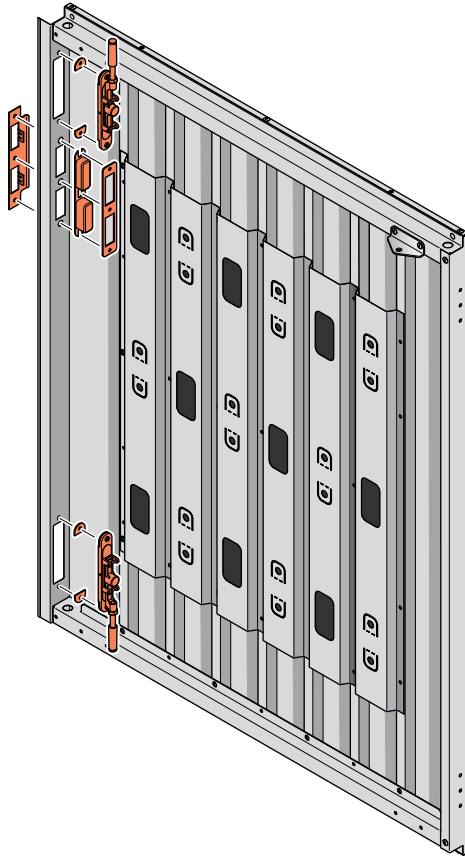

ENSURE THE PLUNGER INDICATED IS FACING THE BOTTOM OF THE DOOR, LOCATE AS SHOWN ABOVE AND SECURE USING ADJACENT FIXING METHOD.

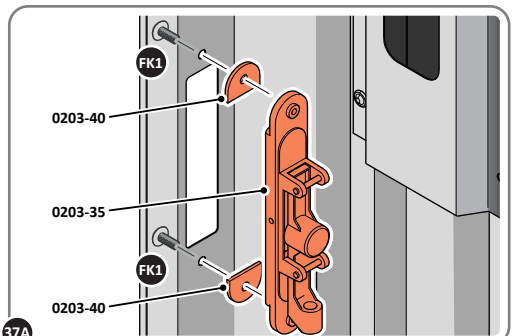

SECURE EACH FLUSH DOOR BOLT ENSURING PLATE PACKER 0203-40 IS LOCATED AS SHOWN ABOVE.

ASSEMBLY STAGE 37 CONTINUED

LOCATE AND SECURE A CORNER BRACE 0204-03 AT EACH LOCATION INDICATED.

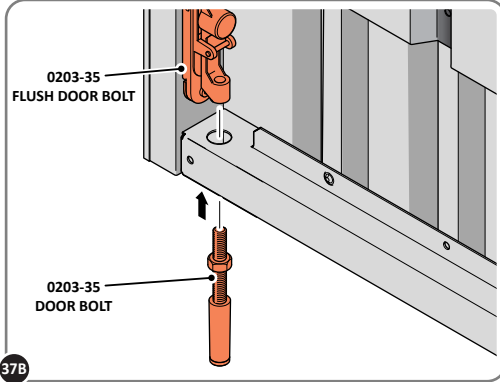

ATTACH DOOR BOLT ONTO FLUSH DOOR BOLT.

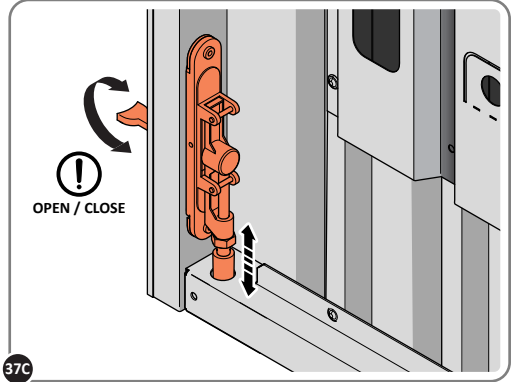

ENSURE FLUSH DOOR BOLT OPENS AND CLOSES.

REPEAT 37A / B / C FOR UPPER FLUSH DOOR BOLT

LOCATE AND SECURE UPPER FLUSH DOOR BOLT 0203-35
USING PROCEDURES 37A / B / C, PLUNGER WILL FACE
UPWARDS TOWARDS THE TOP OF THE DOOR

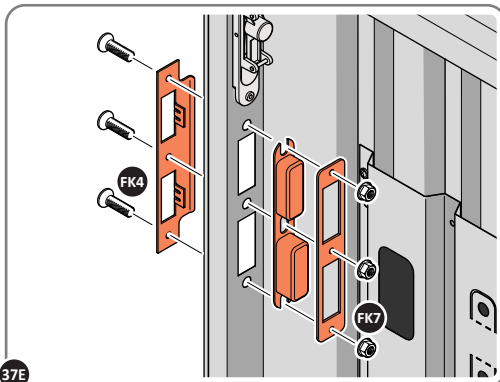
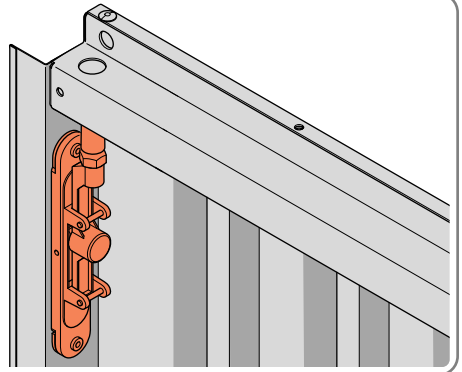

LOCATE AND SECURE EURO MORTICE LOCK 0203-32 AND CATCH PLATE COVER 0203-41 AS SHOWN ABOVE.

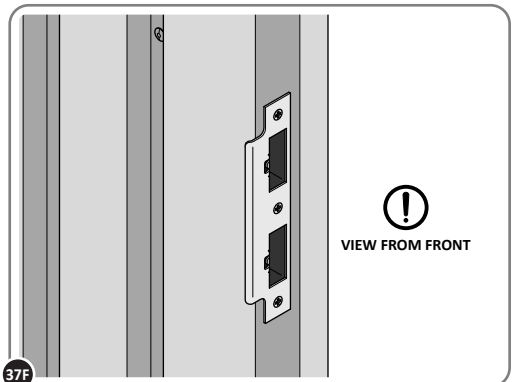

SECURED EURO MORTICE LOCK 0203-32 AS SEEN FROM FRONT.

Assembly Guide

ASSEMBLY STAGE 38

LOCATE AND SECURE A CORNER BRACE 0204-03 AT EACH LOCATION INDICATED.

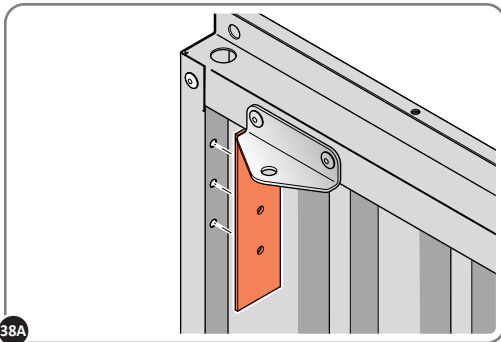
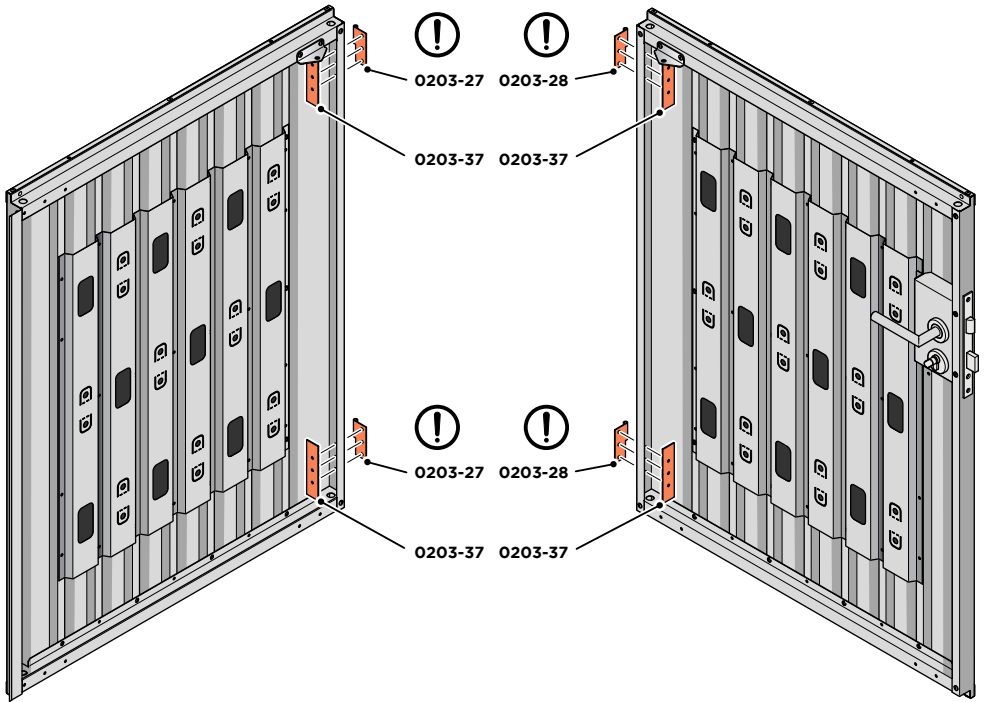

38A

LOCATE DOOR HINGE PLATE 0203-37 WITHIN DOOR AS SHOWN.

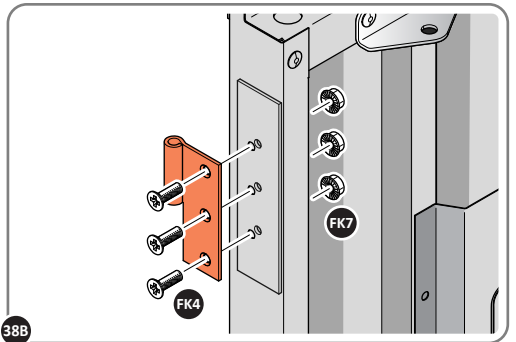

38B

SECURE DOOR HINGE PLATE AND HINGE 0203-27 AND 0203-28 AS SHOWN.
IMPORTANT: ENSURE CORRECT DOOR HINGE IS SECURED TO CORRECT DOOR.

Assembly Guide

ASSEMBLY STAGE 39

LOCATE AND SECURE A DOOR GROMMET 0203-57 AT EACH LOCATION INDICATED.

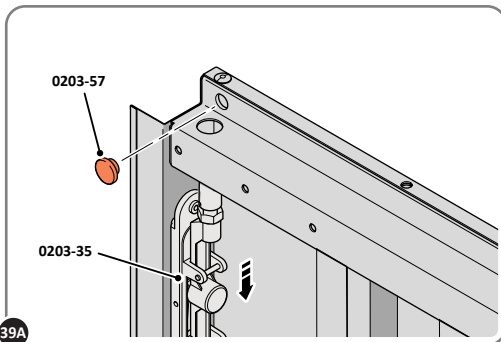
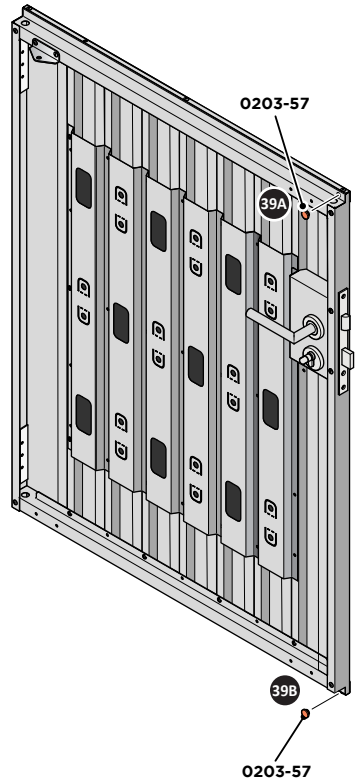
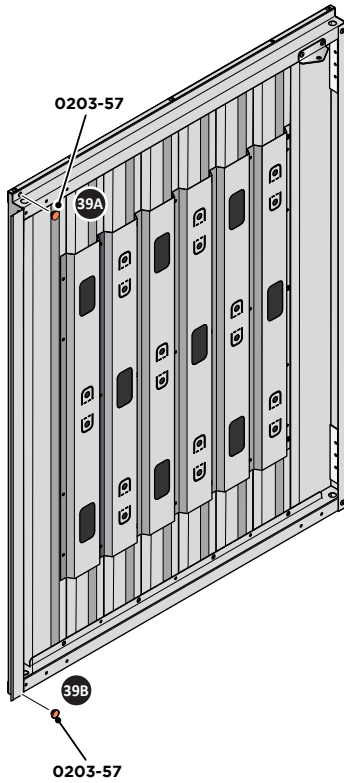

LOCATE DOOR GROMMET 0203-57 AT x2 LOCATIONS INDICATED.
PLEASE NOTE: 0203-35 FLUSH BOLTS ARE ALL IN THE UNLOCKED POSITIONS.

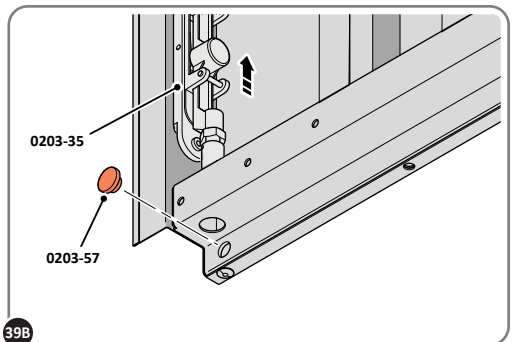

LOCATE DOOR GROMMET 0203-57 AT x2 LOCATIONS AS SHOWN.
PLEASE NOTE: THESE ARE PUSHED ON AND WILL CLICK INTO PLACE.

ASSEMBLY STAGE 40

LOCATE AND SECURE DOOR HINGE PLATE 0203-37 AND LEFT-HAND HINGE 0203-27 AT EACH LOCATION INDICATE.

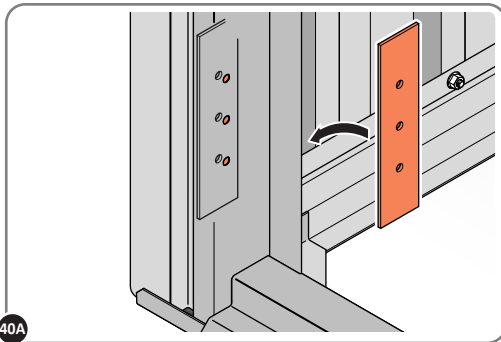
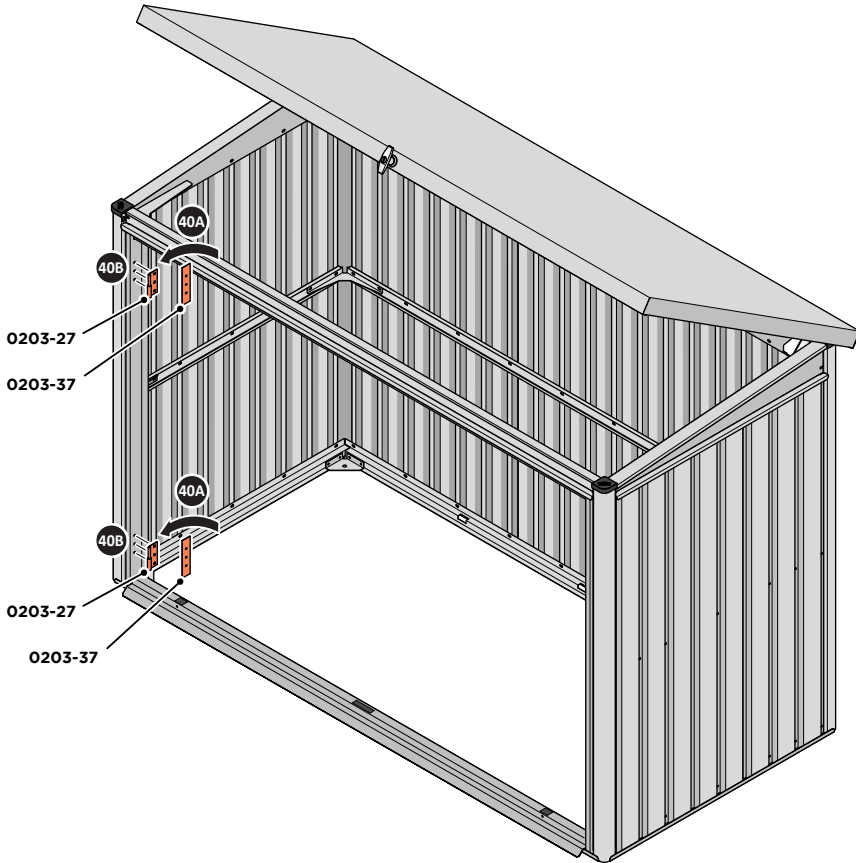

LOCATE DOOR HINGE PLATE 0203-37 WITHIN DOOR AS SHOWN.

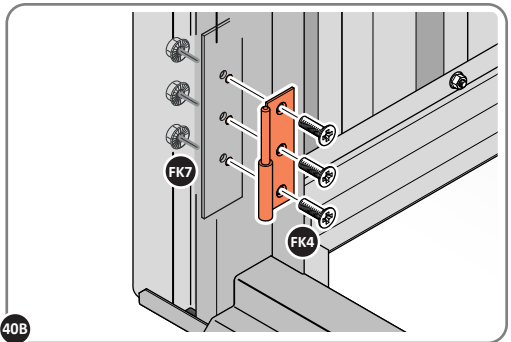

SECURE DOOR HINGE PLATE 0203-37 AND LEFT-HAND HINGE 0203-27 AS SHOWN.
IMPORTANT: ENSURE CORRECT DOOR HINGE IS SECURED TO CORRECT DOOR.

ASSEMBLY STAGE 41

LOCATE AND SECURE DOOR HINGE PLATE 0203-37 AND RIGHT-HAND HINGE 0203-28 AT EACH LOCATION INDICATE.

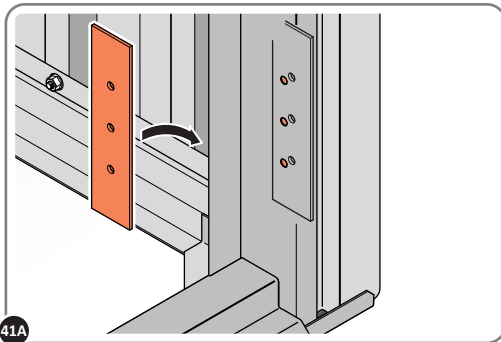
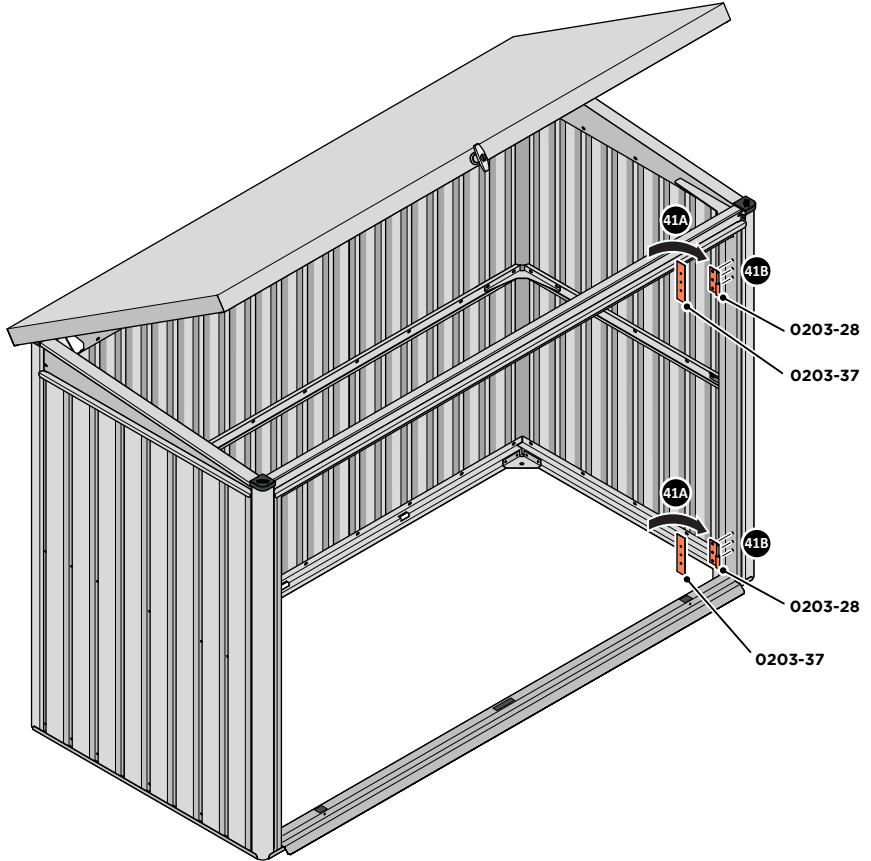

41A LOCATE DOOR HINGE PLATE 0203-37 WITHIN DOOR AS SHOWN.

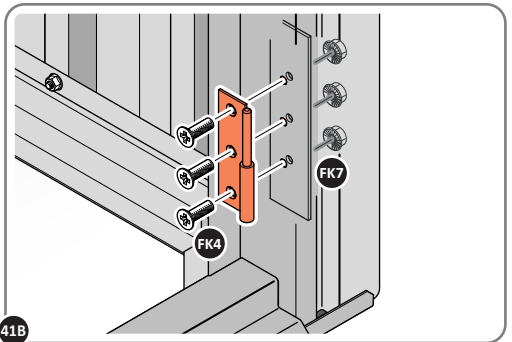

41B SECURE DOOR HINGE PLATE 0203-37 AND RIGHT-HAND HINGE 0203-28 AS SHOWN. IMPORTANT: ENSURE CORRECT DOOR HINGE IS SECURED TO CORRECT DOOR.

ASSEMBLY STAGE 42 LOCATE DOOR ASSEMBLIES ONTO HINGES.

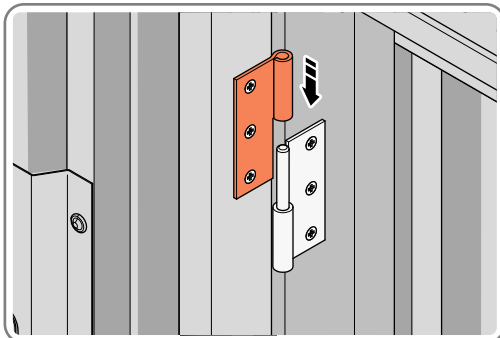
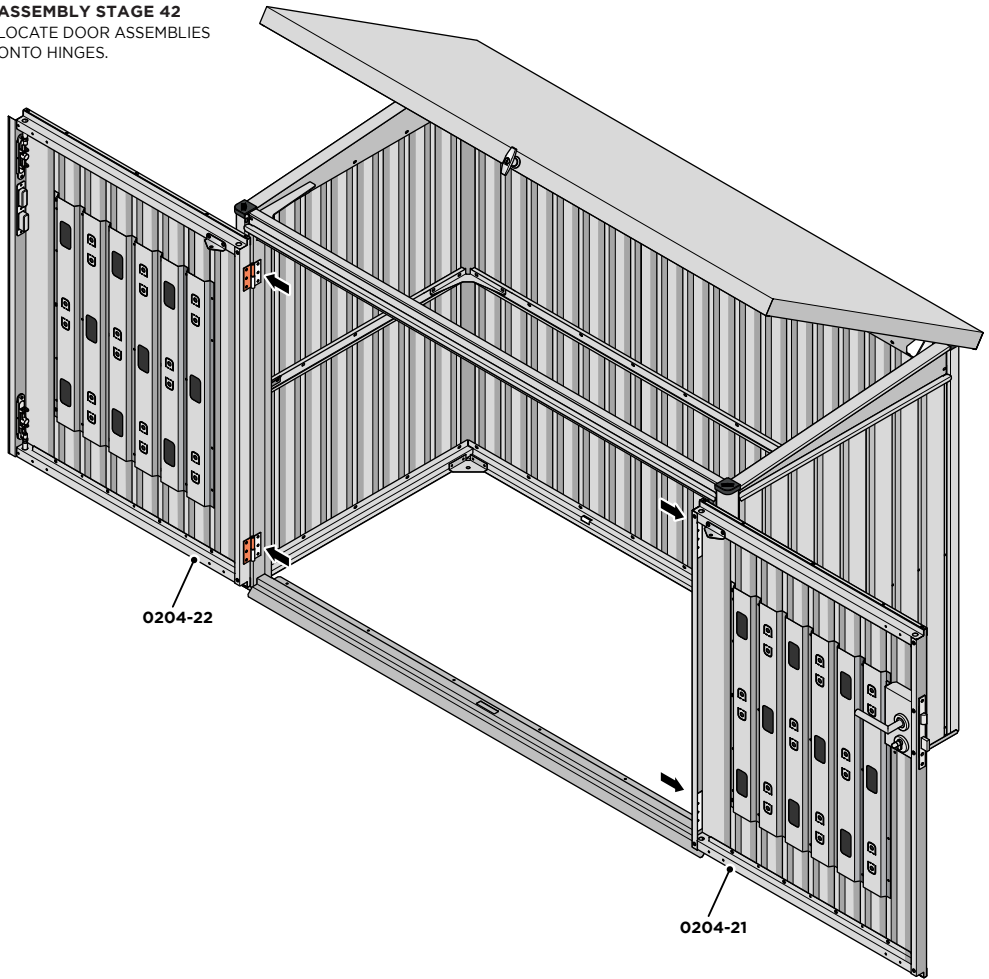

SLIDE EACH DOOR ASSEMBLY ONTO EACH OF THEIR RESPECTIVE HINGES.

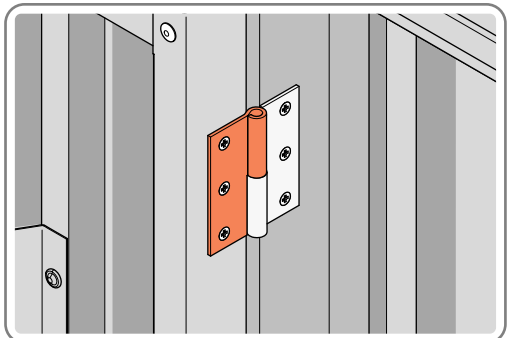

ASSEMBLED DOOR HINGE.

ASSEMBLY STAGE 43
SECURE GAS STRUT
BRACKETS 0205-66.

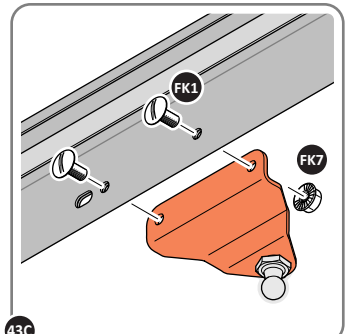
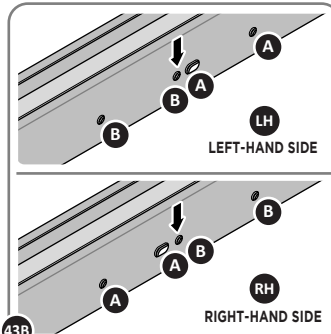
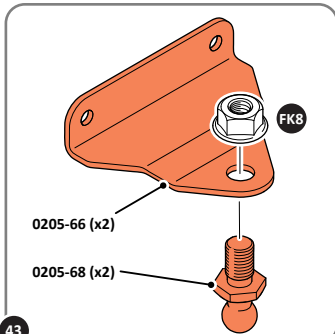
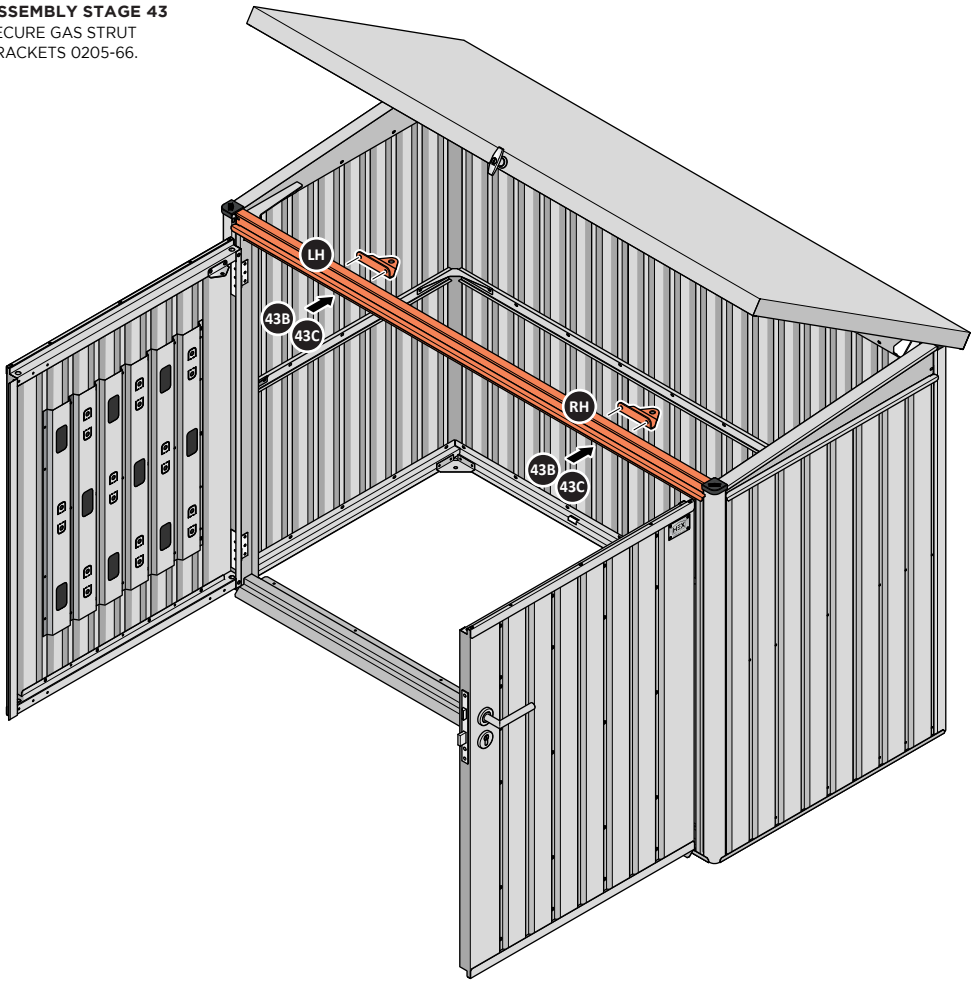

SECURE A BALL STUD 0205-68 ONTO EACH GAS STRUT BRACKET 0205-66.

DETERMINE DOOR OPENING ANGLE:
A: 90° OPENING OR B: 120° OPENING

ALIGN EACH GAS STRUT BRACKET WITH RELEVANT FIXING HOLES, SECURE USING TYPICAL FIXING METHOD ABOVE.

ASSEMBLY STAGE 44

LOCATE AND SECURE GAS STRUT 0205-63.

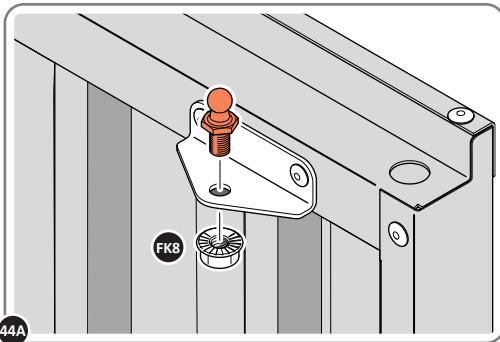
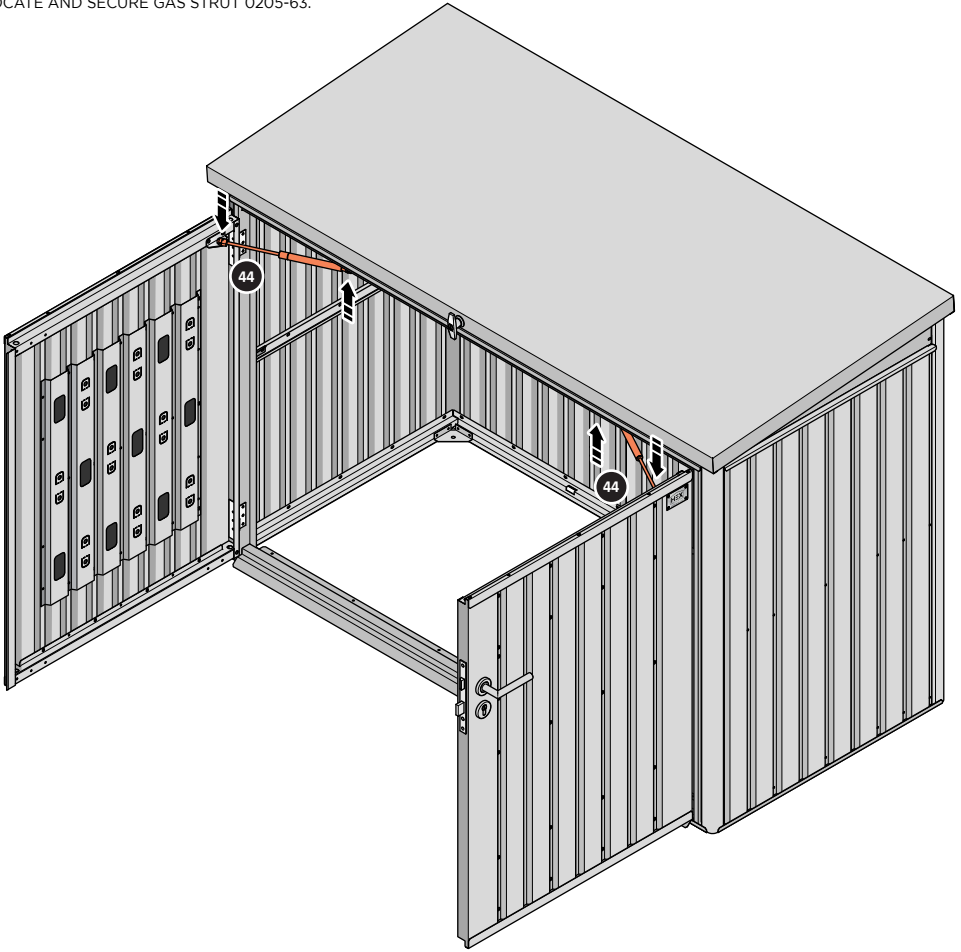

44A

SECURE A BALL STUD 0205-68 ONTO GAS STRUT BRACKETS THAT ARE PRE-RIEVETED ONTO EACH DOOR ASSEMBLY.

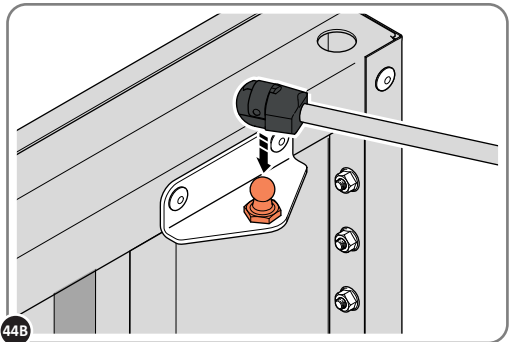

44B

FIX EACH GAS STRUT 0205-63 ONTO BALL STUDS INDICATED ABOVE.
PLEASE NOTE: PUSHES DOWN ON DOOR AND UPWARDS ON DOOR FRAME.

ASSEMBLY STAGE 45

TEST ALL LOCKS / HANDLES AND TIGHTEN ALL FASTENERS TO COMPLETE ASSEMBLY

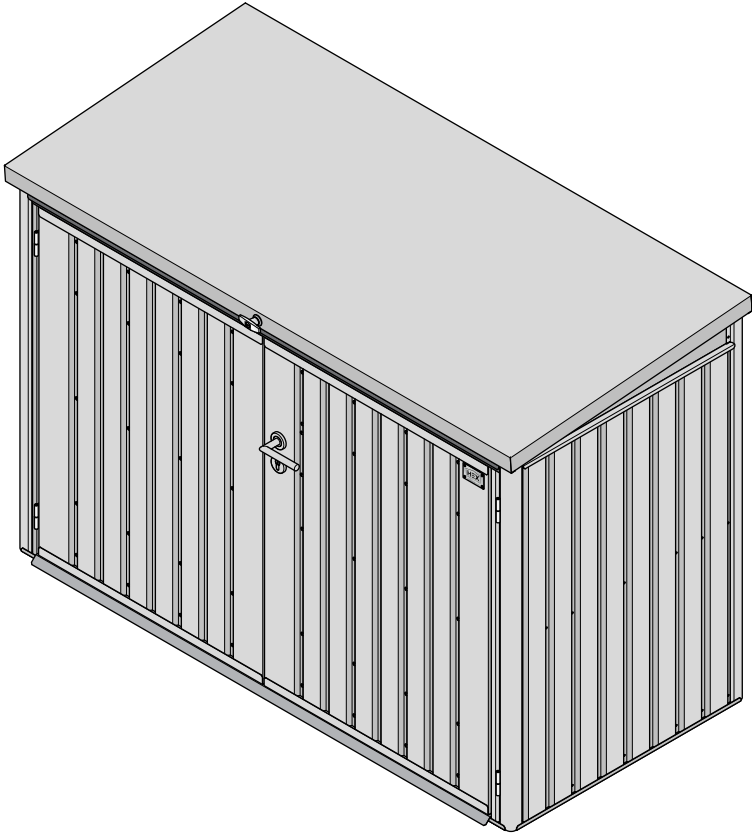

IMPORTANT

ADJUST ALL COMPONENTS FOR BEST POSSIBLE
FIT AND TIGHTEN ALL FASTENERS.

ONCE ALL FASTENERS HAVE BEEN CHECKED AND ARE
SECURE THE ASSEMBLY IS COMPLETE.

WE RECOMMEND YOU ANCHOR YOUR UNIT TO A SOLID
CONCRETE BASE, GUIDANCE CAN BE FOUND ON PAGE 'I'

Caring for your HEX Living product

Your **HEX Living product** is designed to stand the test of time, which is why we're happy to offer a **lifetime warranty** on our products. With zero maintenance required, simply assemble your HEX Living product, and enjoy putting it to great use in your garden.

Periodically, you might want to give your product a clean, these simple care tips are not essential to the performance of your product:

- Remove surface dirt with plain water using a jet wash or sponge, the coating on our products will ensure dirt or mud simply wipes away.
- If you've purchased a HEX Living metal storage solution, periodically clear the roof of fallen leaves.
- If your product has guttering, remove leaves and garden debris as you would on your home.

Ensure you have registered your HEX Living product

Using the unique serial number found on the cover of this document, please visit www.hexliving.co.uk to register your product and access the HEX Living lifetime warranty and video instructions.

Customer Service: +44 (0) 1889 272 056



Doc Ref: 699-0805/B