

Alton

Large Metal Storage Apex Shed Assembly Guide

8 x 6 ft (2.4 x 1.8 m)



IMPORTANT: PLEASE REGISTER YOUR HEX LIVING PRODUCT AFTER ASSEMBLY

Using the unique serial number, simply register your product at www.hexliving.co.uk or use the QR code above to access the HEX Living lifetime warranty and online support.

Affix Serial Number
HERE



PLEASE READ THIS DOCUMENT FULLY PRIOR TO STARTING ASSEMBLY PROCEDURE

The objective of this instruction is to illustrate the recommended assembly sequence for this product, any deviation from this will be the sole responsibility of whoever carries out the assembly.

IMPORTANT: IT IS ADVISABLE THAT THE PRODUCT IS ASSEMBLED AT, OR AS CLOSE AS POSSIBLE TO WHERE IT WILL BE FINALLY LOCATED

Ensure there is adequate clearance where the product is to be located:

Exterior dimensions including overhang (L x W x H)	3000 x 2490 x 2200mm
Footprint dimensions (L x W)	2900 x 2300mm
Clearance required for door to open (W x H)	Doors open outwards 1454 x 1820mm

TWO PERSON ASSEMBLY

Most procedures will not require two people but it may be easier to have assistance.



PERSONAL PROTECTION EQUIPMENT

We advise appropriate personal protective equipment is worn during assembly including eye protection and gloves.



CARING FOR YOUR HEX LIVING PRODUCT

Your **HEX Living** product is designed to stand the test of time, which is why we're happy to offer a lifetime warranty on our products. With zero maintenance required, simply assemble your HEX Living product and enjoy putting it to great use in your garden.

Periodically, you might want to give your product a clean, these simple care tips are not essential to the performance of your product:

- Remove surface dirt with plain water using a jet wash or sponge, the coating on our products will ensure dirt or mud simply wipes away.
- Periodically clear the lid of fallen leaves.
- If your product has guttering, remove leaves and garden debris as you would on your home.

PRODUCT REGISTRATION

IMPORTANT: Prior to assembly, please ensure you have registered your HEX Living product using the unique serial number found on the cover of this document, please visit www.hexliving.co.uk to register your product and access the HEX Living lifetime warranty and video instructions.

GROUND ANCHOR KIT

A Ground Anchor Kit is supplied, this is to secure the product to a solid concrete base, the shed has x4 clamp plates in each corner.

WE STRONGLY ADVISE THAT THE SHED IS ANCHORED USING THIS KIT

The diagram illustrates the typical fixing method, once the shed is assembled, access the clamp brackets by removing the appropriate floor panel and secure as required.

GROUND ANCHOR KIT

Part Ref: FK8
M8 x 50mm Coach Screw
Qty: x8

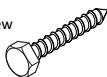

Part Ref: FK7
Expansion Plug
Qty: x8

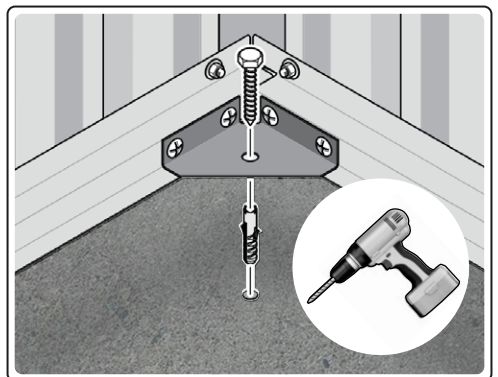

Assembly Guide

ENSURE ALL ITEMS LISTED ARE PRESENT PRIOR TO STARTING ASSEMBLY PROCEDURE

SCALE OF ITEMS WILL VARY TO AID VISUAL IDENTIFICATION

Part Ref: 0213-01
Qty: x2

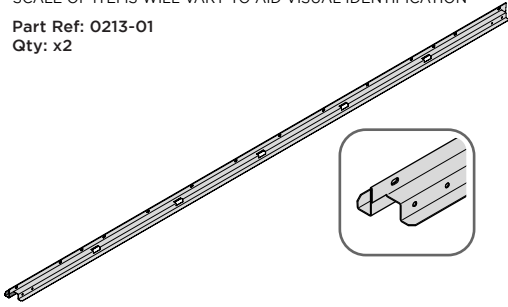

Part Ref: 0212-03
Qty: x1

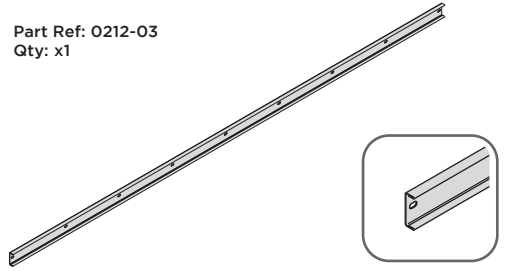

Part Ref: 0212-01
Qty: x2

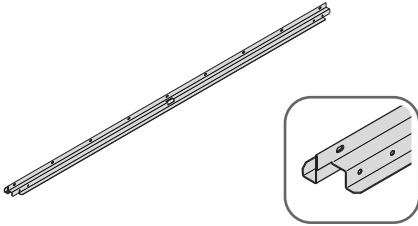

Part Ref: 0205-09
Qty: x2

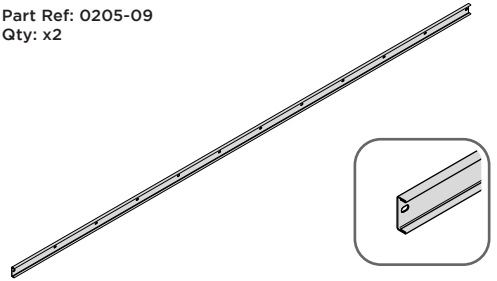

Part Ref: 0205-12 (1850 x 625mm)
Qty: x8

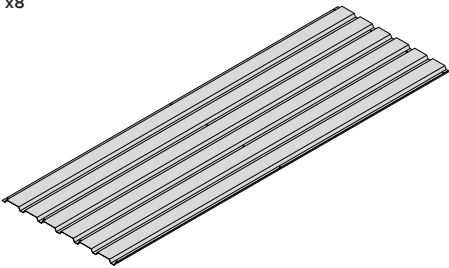

Part Ref: 0205-13 (1850 x 425mm)
Qty: x3

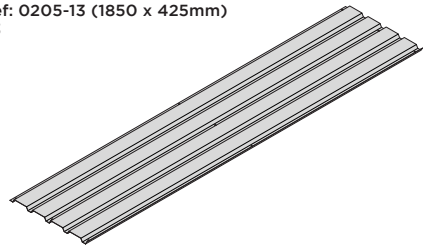

Part Ref: 0205-14 (1885mm Long)
Qty: x4

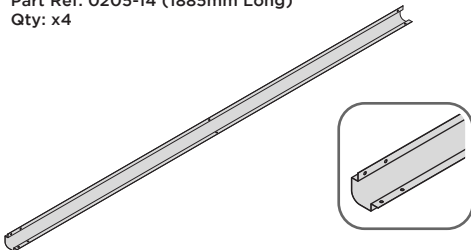

Part Ref: 0205-74
Qty: x1

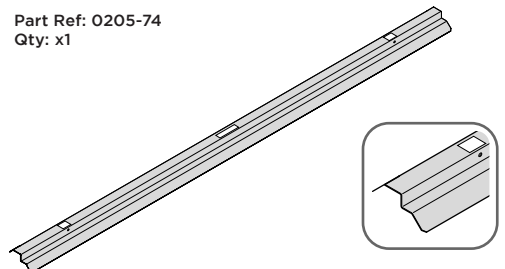

Assembly Guide

ENSURE ALL ITEMS LISTED ARE PRESENT PRIOR TO STARTING ASSEMBLY PROCEDURE

SCALE OF ITEMS WILL VARY TO AID VISUAL IDENTIFICATION

Part Ref: 0256-01
Qty: x1

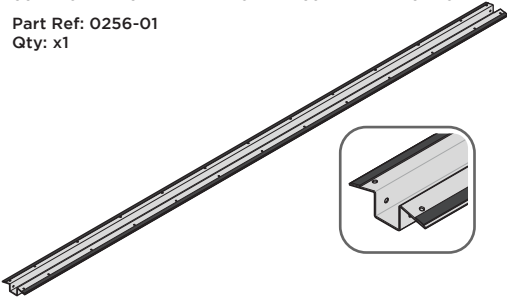

Part Ref: 0215-02
Qty: x2

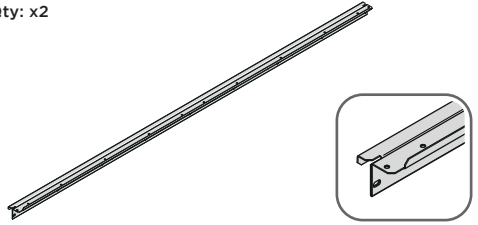

Part Ref: 0205-16 (R/H)
Qty: x1

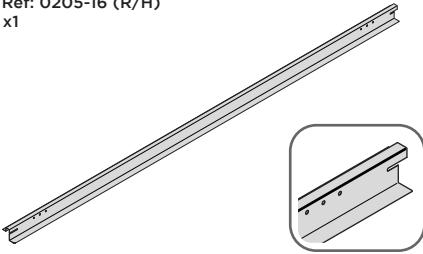

Part Ref: 0244-06
Qty: x4

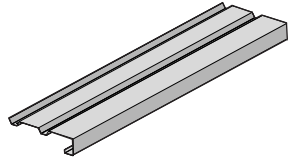

Part Ref: 0205-17 (L/H)
Qty: x1

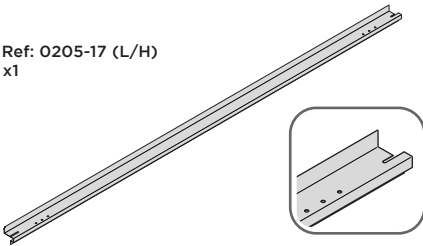

Part Ref: 0244-04
Qty: x6

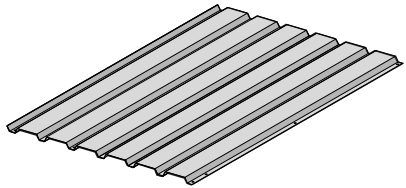

Part Ref: 0213-02
Qty: x2

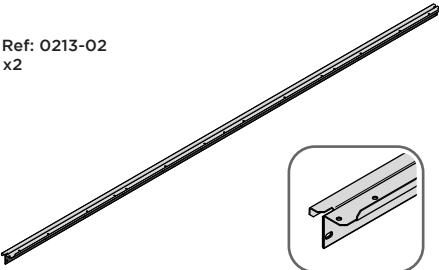

Part Ref: 0244-05
Qty: x2

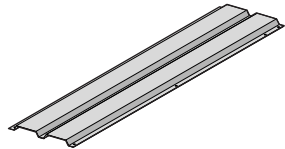

Assembly Guide

ENSURE ALL ITEMS LISTED ARE PRESENT PRIOR TO STARTING ASSEMBLY PROCEDURE
SCALE OF ITEMS WILL VARY TO AID VISUAL IDENTIFICATION

Part Ref: 0244-03
Qty: x2

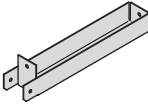

Part Ref: 0205-39
Qty: x4



Part Ref: 0205-38-02
Qty: x2

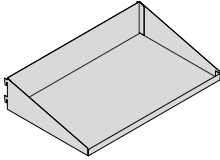

Part Ref: 0213-21
Qty: x2

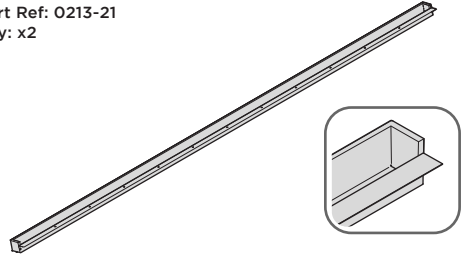

Part Ref: 0205-38-01
Qty: x2

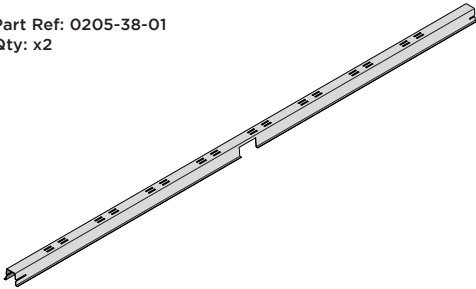

Part Ref: 0213-09
Qty: x2

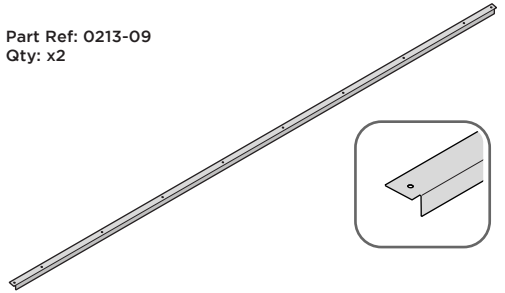

Part Ref: 0205-37 (L/H)
Qty: x1

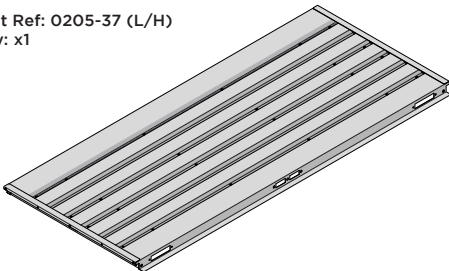

Part Ref: 0205-36 (R/H)
Qty: x1

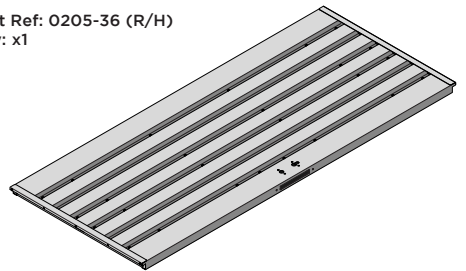

Assembly Guide

ENSURE ALL ITEMS LISTED ARE PRESENT PRIOR TO STARTING ASSEMBLY PROCEDURE

SCALE OF ITEMS WILL VARY TO AID VISUAL IDENTIFICATION

Part Ref: 0256-05
Qty: x2

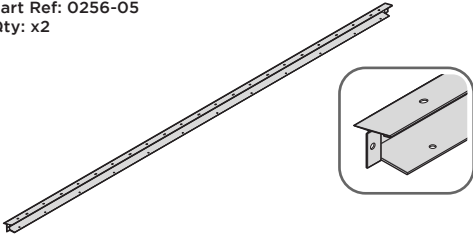

Part Ref: 0256-06
Qty: x1

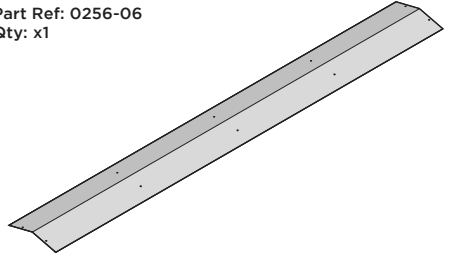

Part Ref: 0244-11
Qty: x2

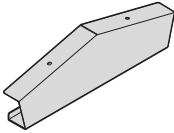

Part Ref: 0244-15
Qty: x2

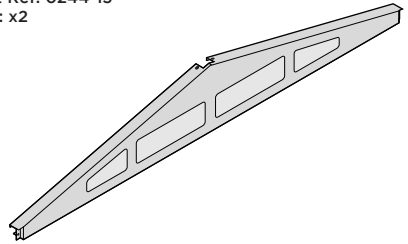

Part Ref: 0244-16
Qty: x3

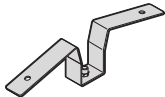

Assembly Guide

ENSURE ALL ITEMS LISTED ARE PRESENT PRIOR TO STARTING OF ASSEMBLY PROCEDURE

SCALE OF ITEMS WILL VARY TO AID VISUAL IDENTIFICATION

Part Ref: 0203-03
Qty: x4



Part Ref: 0203-41
Qty: x1

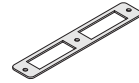

Part Ref: 0203-15
Qty: x4



Part Ref: 0205-57
Qty: x4



Part Ref: 0203-28 (L/H Assembly)
Qty: x2



Part Ref: 0205-63
Qty: x2

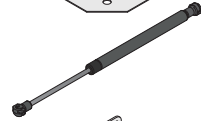

Part Ref: 0203-27 (R/H Assembly)
Qty: x2



Part Ref: 0205-66
Qty: x2



Part Ref: 0203-32 (Assembly)
Qty: x1

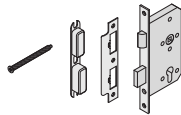

Part Ref: 0205-68
Qty: x4



Part Ref: 0203-33 (Assembly)
Qty: x1

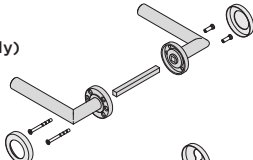

Part Ref: 0205-52
Qty: x2



Part Ref: 0205-53
Qty: x2



Part Ref: 0203-34 (Assembly)
Qty: x1

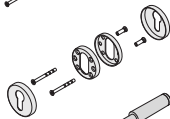

Part Ref: FK1
M4 x 10mm Roofing Bolt
This will be Pozi or Slotted
Qty: x293



Part Ref: 0203-35
Qty: x2

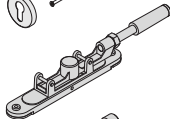

Part Ref: FK2
No.8 x 13mm Eco Fix
Qty: x25



Part Ref: 0203-36
Qty: x1



Part Ref: FK3
M4 x 12mm C'Sunk Pozi Pan
Qty: x34



Part Ref: 0203-37
Qty: x4

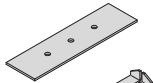

Part Ref: FK4
M4 Rubber Washer
Qty: x63



Part Ref: 0203-39
Qty: x4

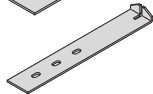

Part Ref: FK5
M4 Serrated Flange Nut
Qty: x319



Part Ref: 0203-40
Qty: x4



Part Ref: FK6
M8 Serrated Flange Nut
Qty: x5



Part Ref: 0203-57
Qty: x4



Part Ref: FK7
Expansion Plug
Qty: x8



Part Ref: FK8
M8 x 50mm Coach Screw
Qty: x8

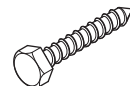

Assembly Guide

ASSEMBLY STAGE 1

LOCATE AND SECURE A CORNER BRACE 0203-03 AT EACH LOCATION INDICATED.

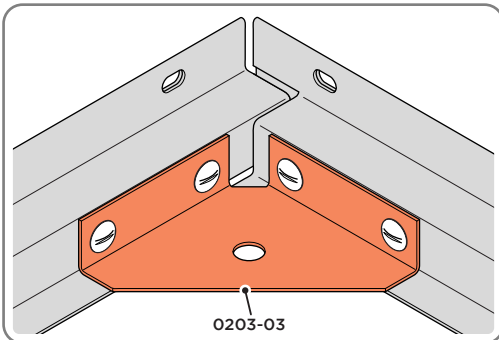
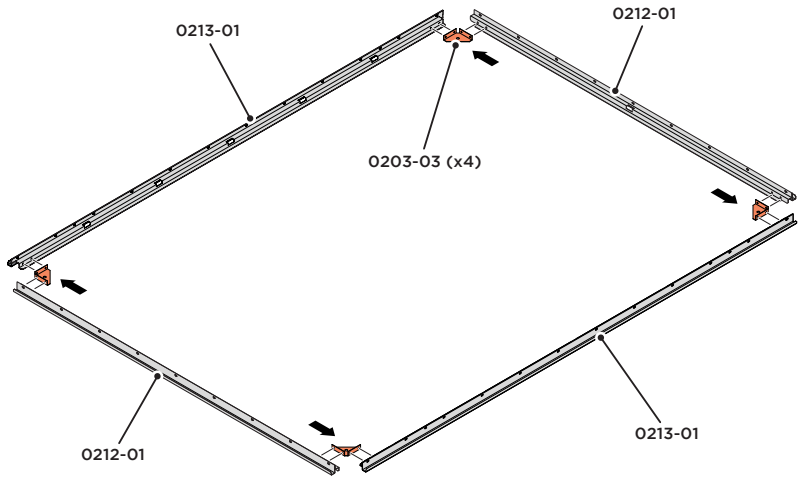

SECURE EACH CORNER BRACE 0203-03 AS SHOWN ABOVE.

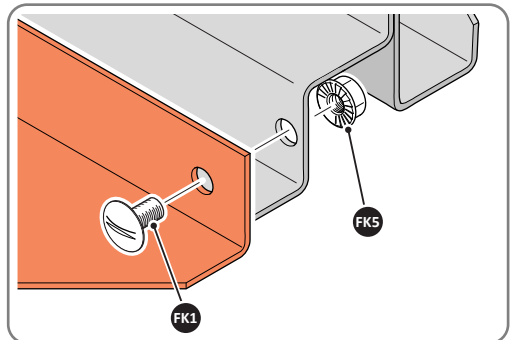

PLEASE NOTE: SECTION VIEW OF TYPICAL FIXING METHOD.

Assembly Guide

ASSEMBLY STAGE 2

LOCATE AND LOOSELY ATTACH WALL PANEL 0205-13 (1850 x 425mm).

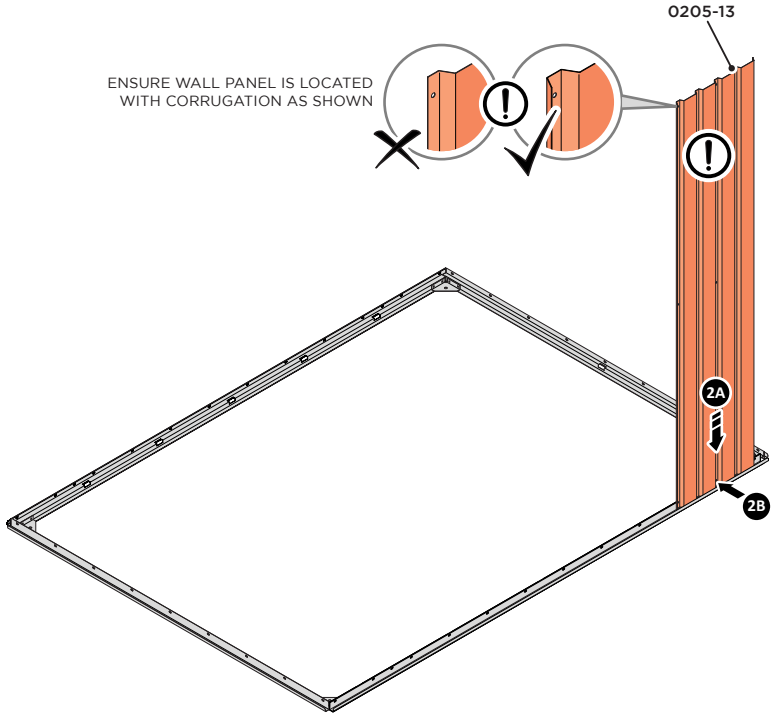

ENSURE WALL PANEL IS LOCATED WITH CORRUGATION AS SHOWN

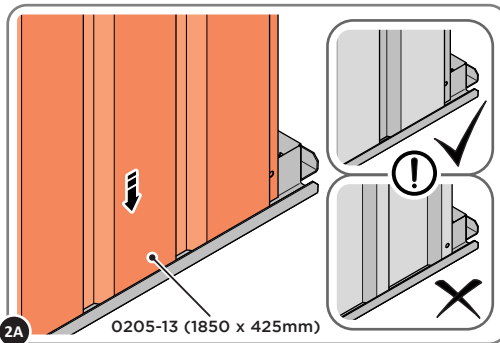

2A 0205-13 (1850 x 425mm)

LOCATE WALL PANEL 0205-13 INTO POSITION AS SHOWN ABOVE.
IMPORTANT: ENSURE PANEL IS IN THE CORRECT ORIENTATION.

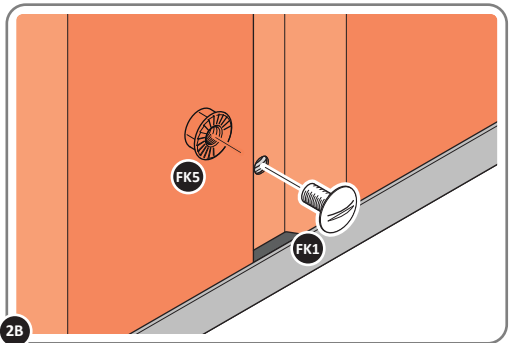

2B

LOOSELY ATTACH WALL PANEL ONTO FLOOR RAIL AT LOCATION INDICATED.

Assembly Guide

ASSEMBLY STAGE 3

LOCATE AND LOOSELY ATTACH CORNER POST 0205-14.

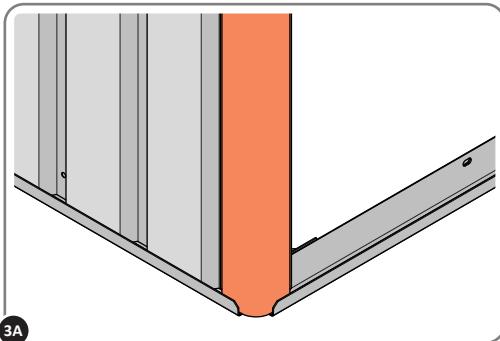
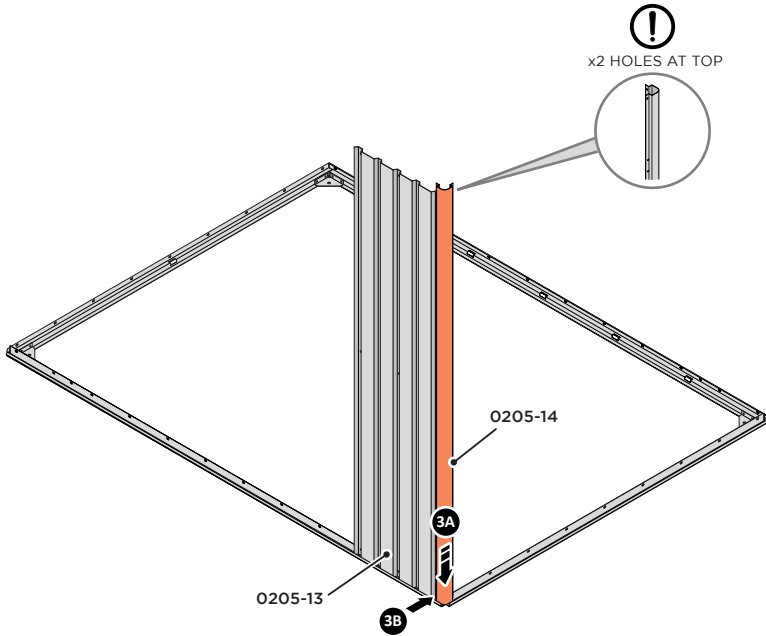

3A LOCATE CORNER POST 0205-14 AS SHOWN ABOVE.

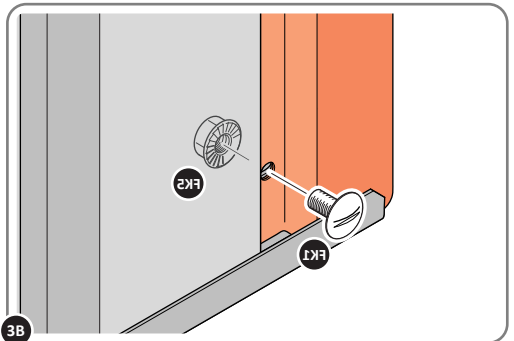

3B LOOSELY ATTACH CORNER POST AT LOCATION INDICATED ONLY.
IMPORTANT: DO NOT SECURE AT UPPER FIXING POINT AT THIS STAGE.

Assembly Guide

ASSEMBLY STAGE 4

LOCATE AND LOOSELY ATTACH WALL PANEL 0205-12 (1850 x 625mm).

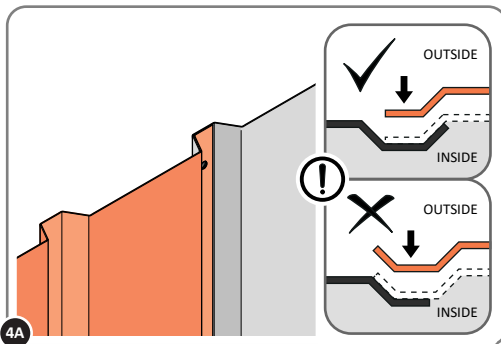
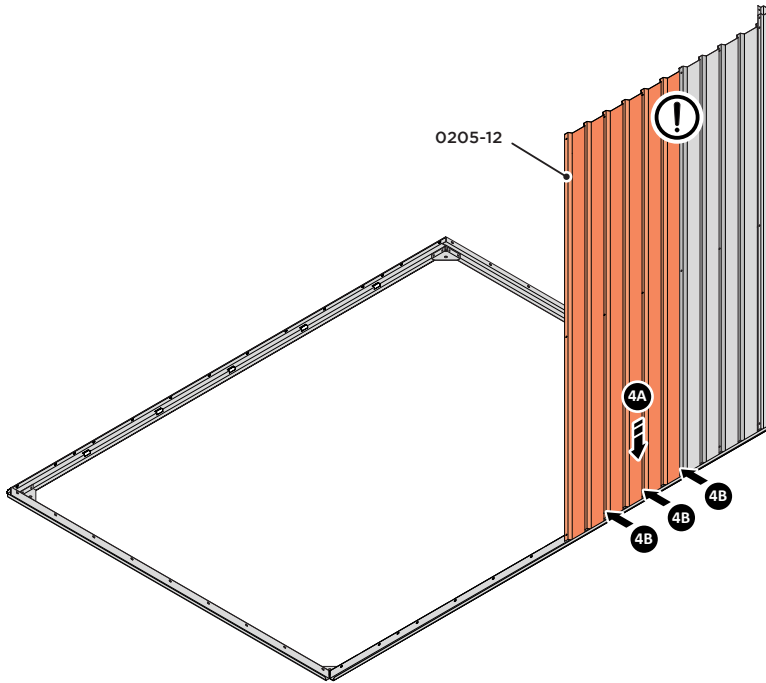

4A LOCATE WALL PANEL 0205-12 INTO POSITION AS SHOWN ABOVE.
IMPORTANT: ENSURE PANEL IS IN THE CORRECT ORIENTATION.

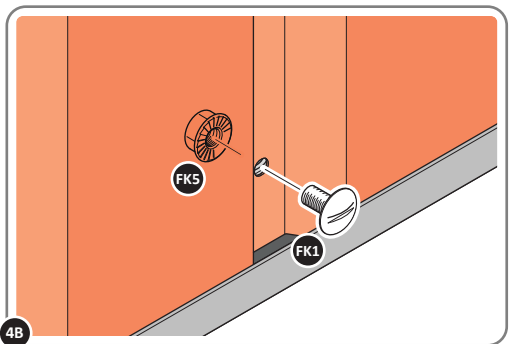

4B LOOSELY ATTACH BACK WALL PANEL AT x3 LOCATIONS INDICATED ONLY.
IMPORTANT: DO NOT SECURE ANY FIXING POINTS OTHER THAN THOSE INDICATED.

ASSEMBLY STAGE 5

LOCATE AND LOOSELY ATTACH MID CENTRE BRACE 0205-09.

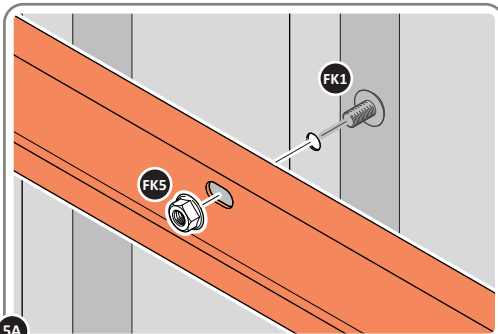
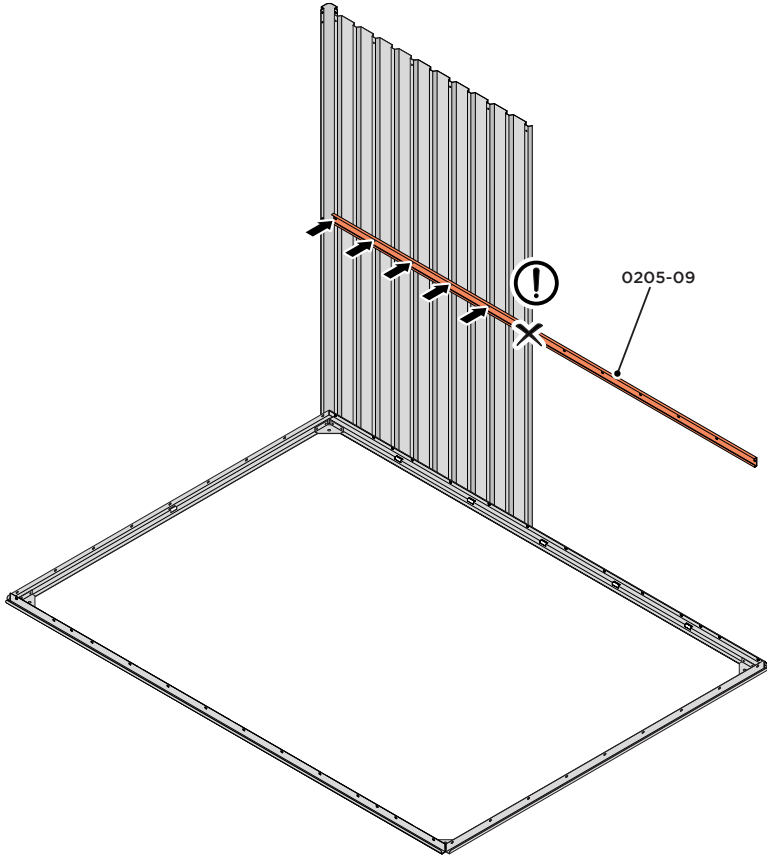

5A

LOCATE AND LOOSELY ATTACH MID CENTRE BRACE 0205-09 AS SHOWN AT X3 LOCATIONS INDICATED ABOVE.

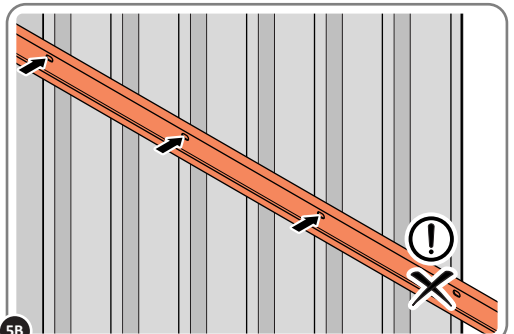

5B

LOOSELY ATTACH AT X5 LOCATIONS INDICATED ONLY.
IMPORTANT: DO NOT SECURE AT OUTER FIXING POINT INDICATED.

Assembly Guide

ASSEMBLY STAGE 6

LOCATE AND LOOSELY ATTACH WALL PANEL 0205-12 (1850 x 625mm).

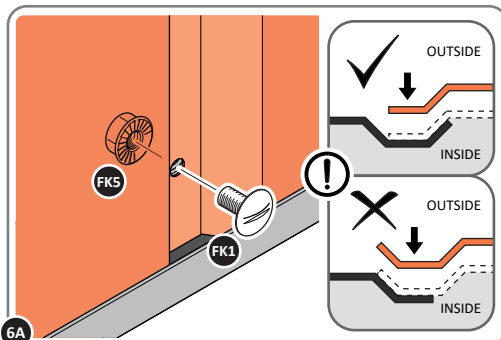
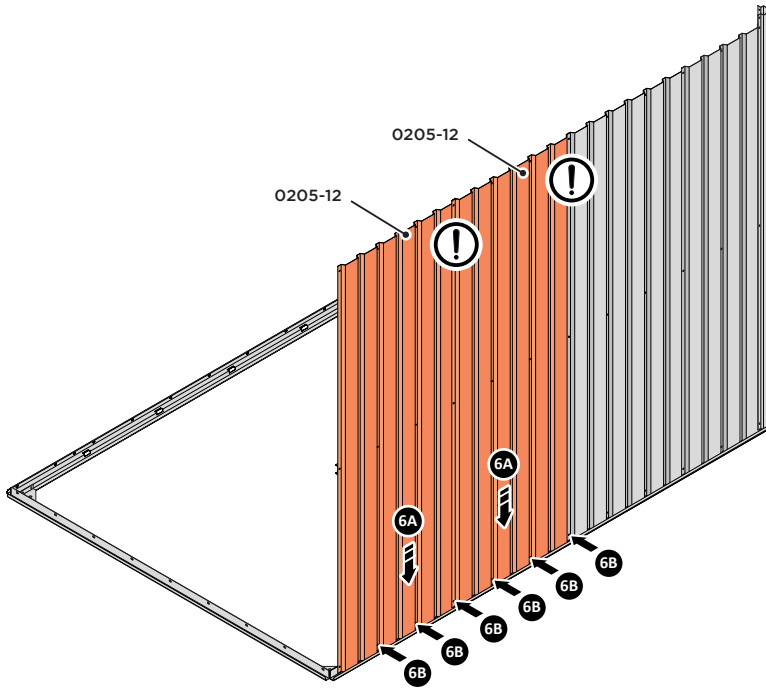

LOCATE AND LOOSELY ATTACH WALL PANEL AT X3 LOCATIONS INDICATED.
IMPORTANT: ENSURE PANEL IS IN THE CORRECT ORIENTATION.

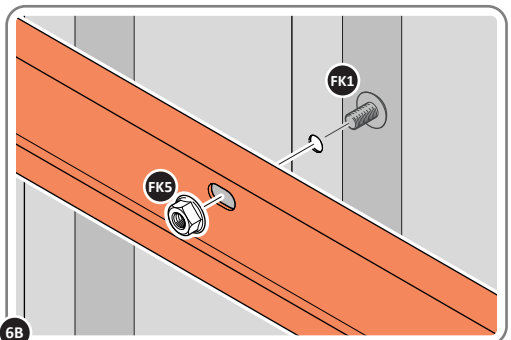

LOOSELY ATTACH AT X3 LOCATIONS INDICATED ONLY.

Assembly Guide

ASSEMBLY STAGE 7

LOCATE AND LOOSELY ATTACH CORNER POST 0205-14.

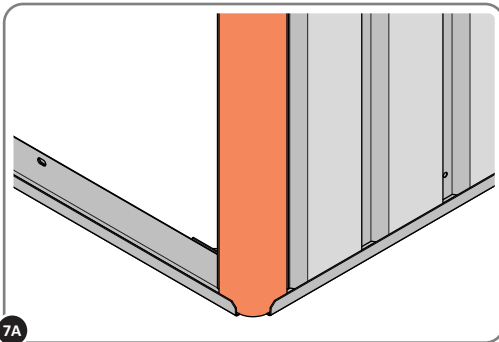
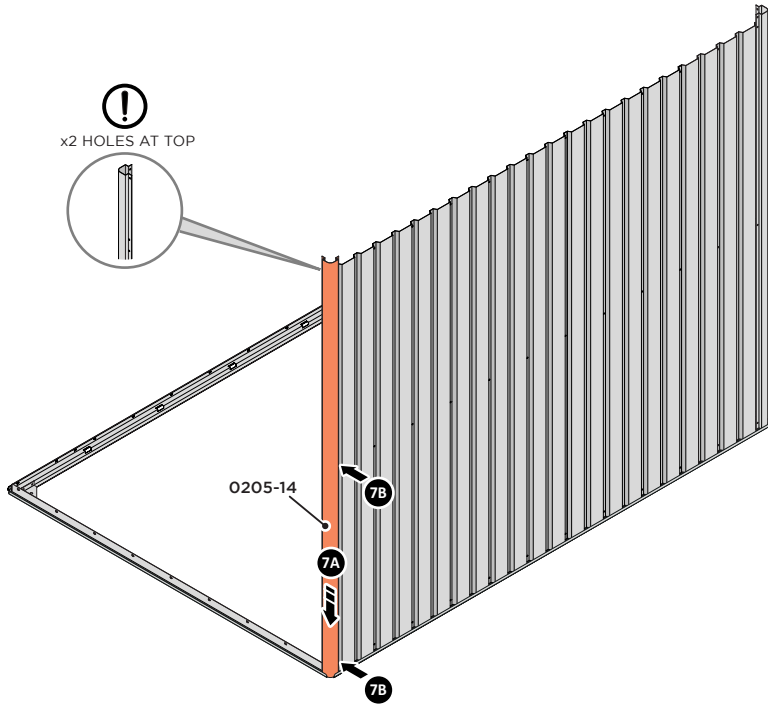

7A LOCATE CORNER POST 0205-14 AS SHOWN ABOVE.

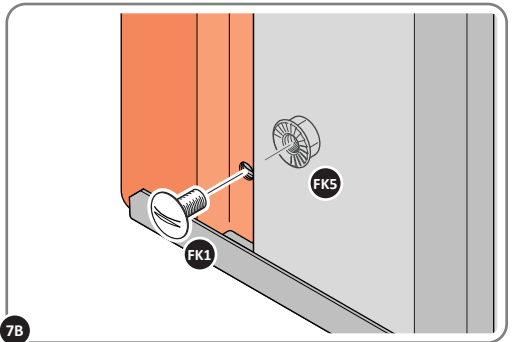

7B LOOSELY ATTACH CORNER POST AT x2 LOCATIONS INDICATED ONLY.
IMPORTANT: DO NOT SECURE AT UPPER FIXING POINT AT THIS STAGE.

Assembly Guide

ASSEMBLY STAGE 8

LOCATE AND LOOSELY ATTACH WALL PANEL 0205-13 (1850 x 425mm).

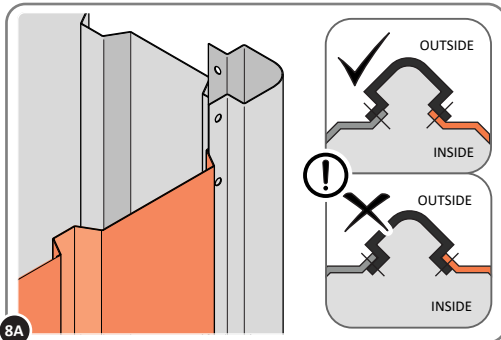
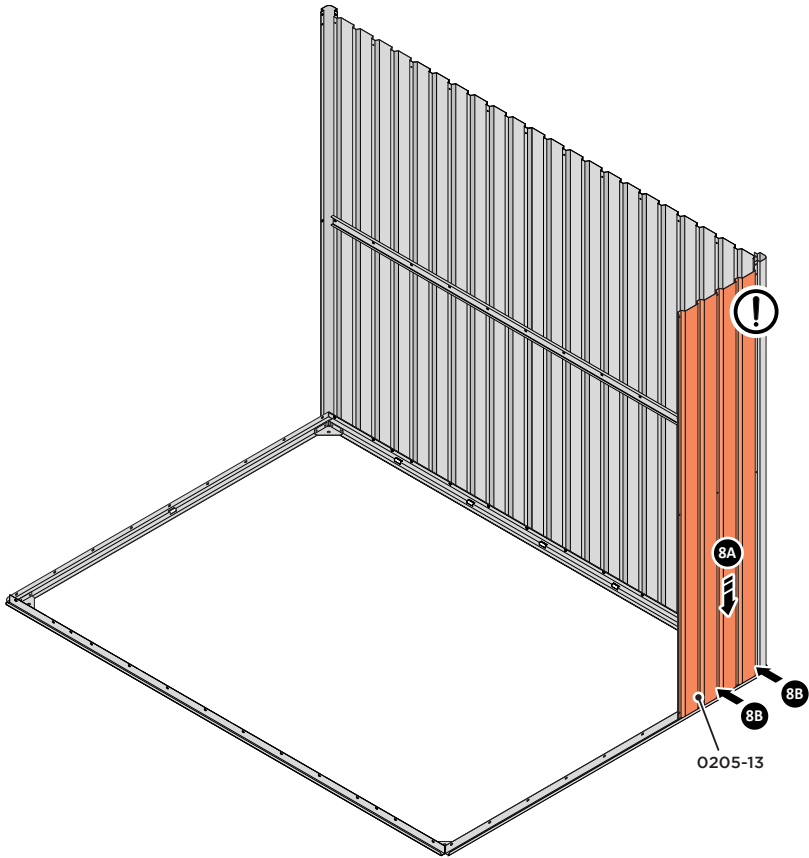

8A

LOCATE FIRST WALL PANEL 0205-13 AS SHOWN ABOVE.
IMPORTANT: ENSURE PANEL IS IN THE CORRECT ORIENTATION.

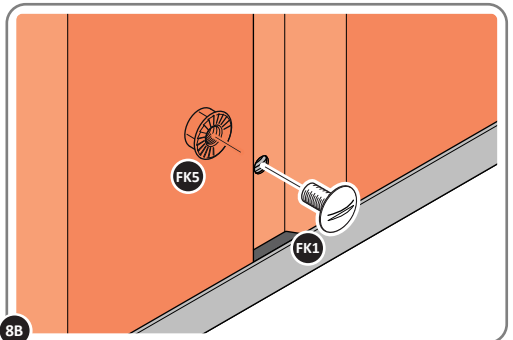

8B

LOOSELY ATTACH WALL PANEL AT x2 LOCATIONS INDICATED ONLY.
IMPORTANT: DO NOT SECURE ANY FIXING POINTS OTHER THAN THOSE INDICATED.

Assembly Guide

ASSEMBLY STAGE 9

LOCATE AND LOOSELY ATTACH WALL PANEL 0205-12 (1850 x 625mm).

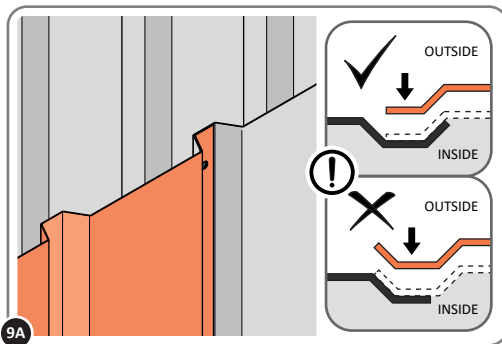
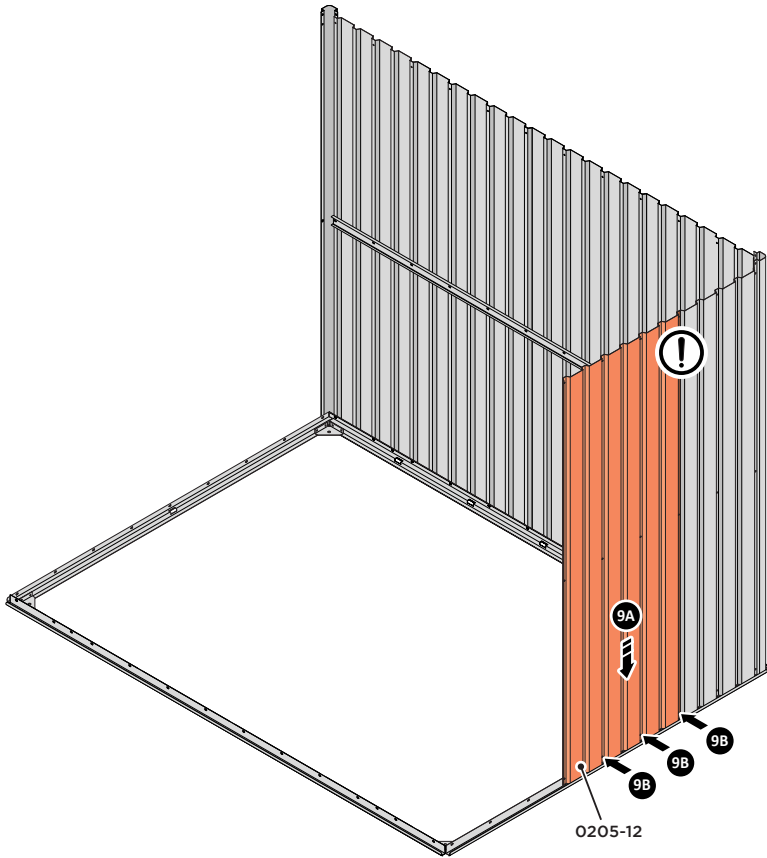

9A

LOCATE WALL PANEL 0205-12 INTO POSITION AS SHOWN ABOVE.
IMPORTANT: ENSURE PANEL IS IN THE CORRECT ORIENTATION.

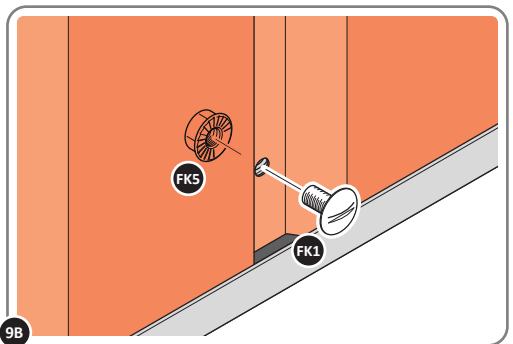

9B

LOOSELY ATTACH WALL PANEL AT x3 LOCATIONS INDICATED ONLY.
IMPORTANT: DO NOT SECURE ANY FIXING POINTS OTHER THAN THOSE INDICATED.

ASSEMBLY STAGE 10

LOCATE AND LOOSELY ATTACH MID CENTRE BRACE 0212-03.

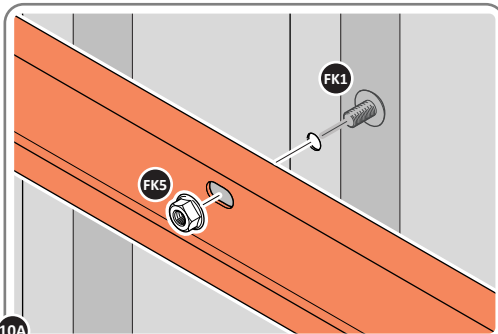
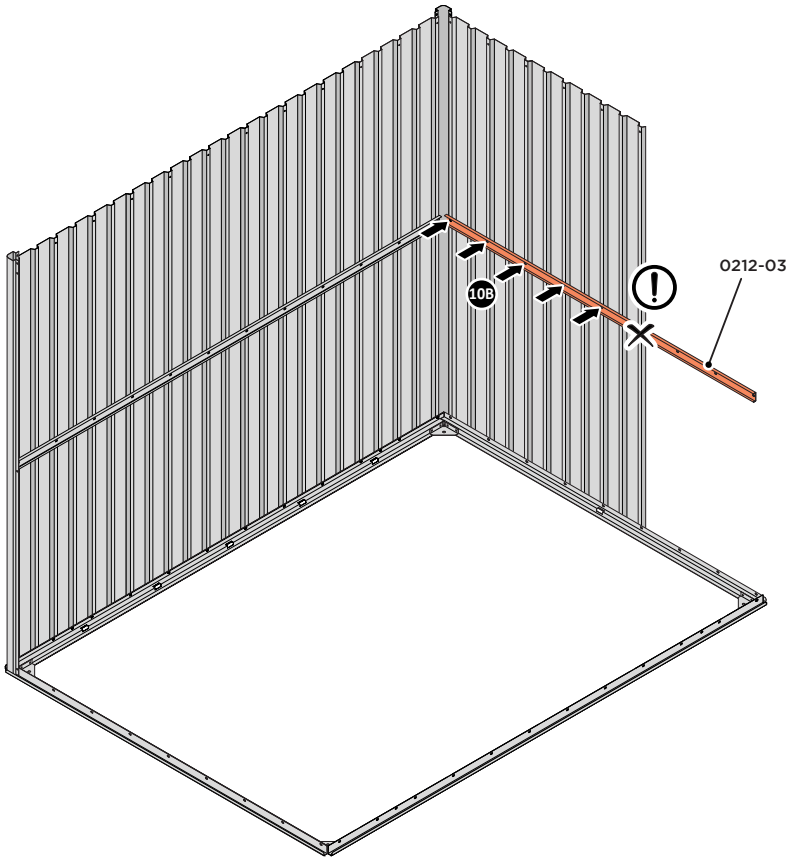

10A LOCATE AND LOOSELY ATTACH MID CENTRE BRACE 0212-03 AS SHOWN AT LOCATIONS INDICATED ABOVE.

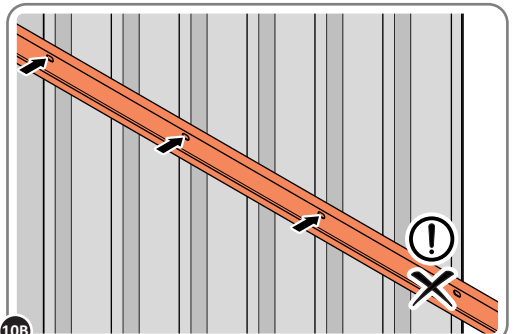

10B LOOSELY ATTACH AT x5 LOCATIONS INDICATED ONLY.
IMPORTANT: DO NOT SECURE AT OUTER FIXING POINT INDICATED.

ASSEMBLY STAGE 11

LOCATE AND LOOSELY ATTACH WALL PANEL 0205-12 (1850 x 625mm).

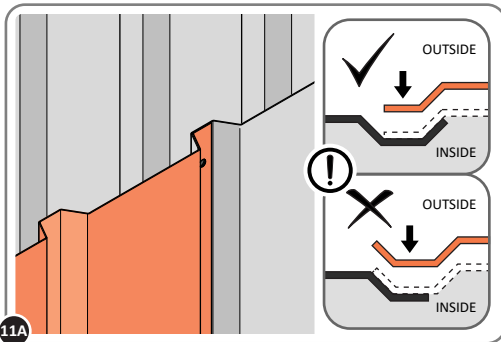
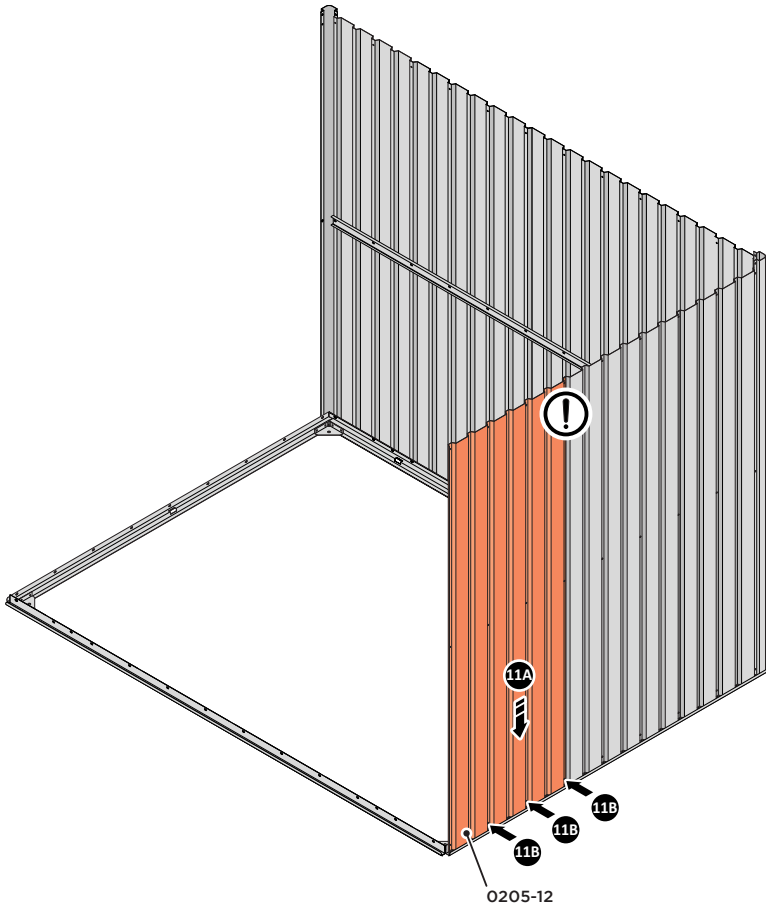

11A
LOCATE WALL PANEL 0205-12 INTO POSITION AS SHOWN ABOVE.
IMPORTANT: ENSURE PANEL IS IN THE CORRECT ORIENTATION.

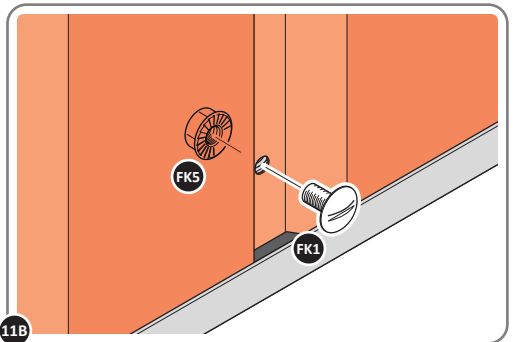

11B
LOOSELY ATTACH WALL PANEL AT x3 LOCATIONS INDICATED ONLY.
IMPORTANT: DO NOT SECURE ANY FIXING POINTS OTHER THAN THOSE INDICATED.

Assembly Guide

ASSEMBLY STAGE 12

LOCATE AND LOOSELY ATTACH CORNER POST 0205-14.

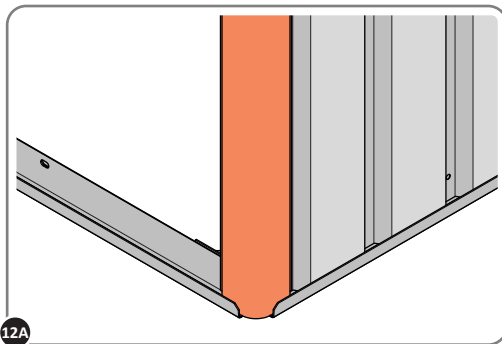
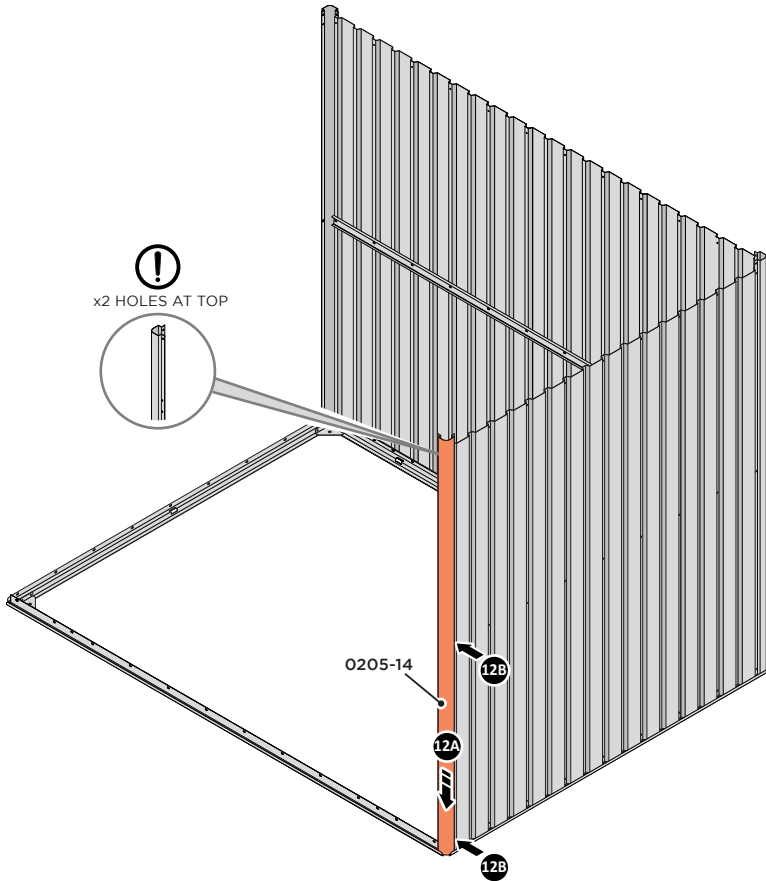

12A LOCATE CORNER POST 0205-14 AS SHOWN ABOVE.

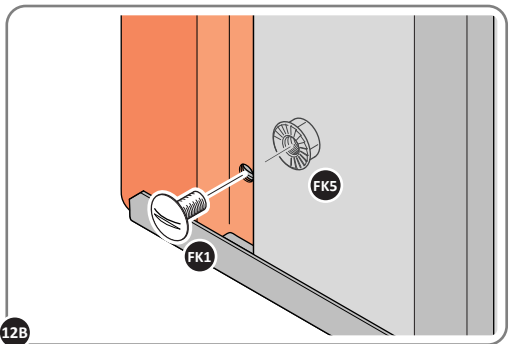

12B LOOSELY ATTACH CORNER POST AT X2 LOCATIONS INDICATED ONLY.
IMPORTANT: DO NOT SECURE AT UPPER FIXING POINT AT THIS STAGE.

Assembly Guide

ASSEMBLY STAGE 13

LOCATE AND LOOSELY ATTACH WALL PANEL 0205-12 (1850 x 625mm).

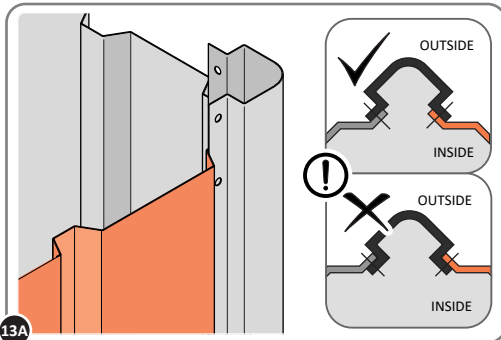
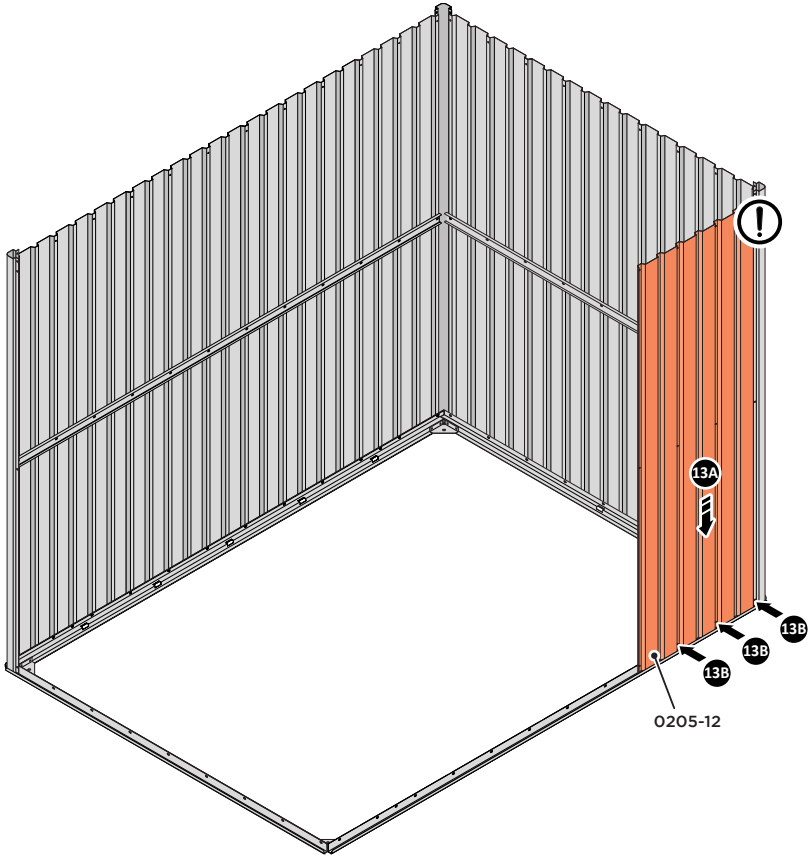

13A

LOCATE FIRST WALL PANEL 0205-12 AS SHOWN ABOVE.
IMPORTANT: ENSURE PANEL IS IN THE CORRECT ORIENTATION.

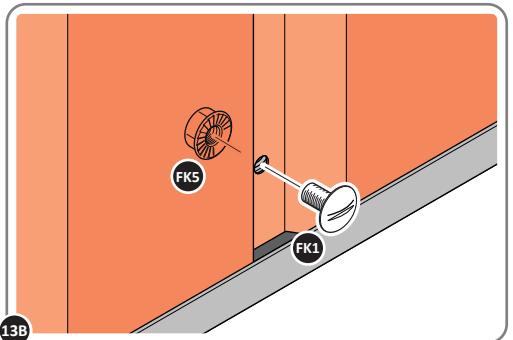

13B

LOOSELY ATTACH WALL PANEL AT x2 LOCATIONS INDICATED ONLY.
IMPORTANT: DO NOT SECURE ANY FIXING POINTS OTHER THAN THOSE INDICATED.

Assembly Guide

ASSEMBLY STAGE 14

LOCATE AND LOOSELY ATTACH MID CENTRE BRACE 0205-09.

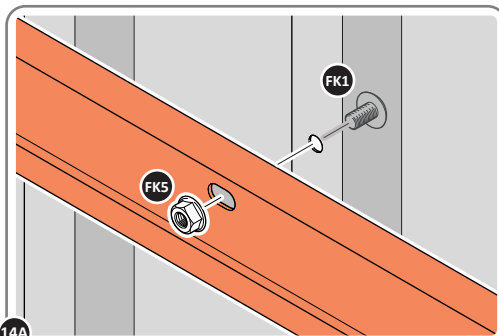
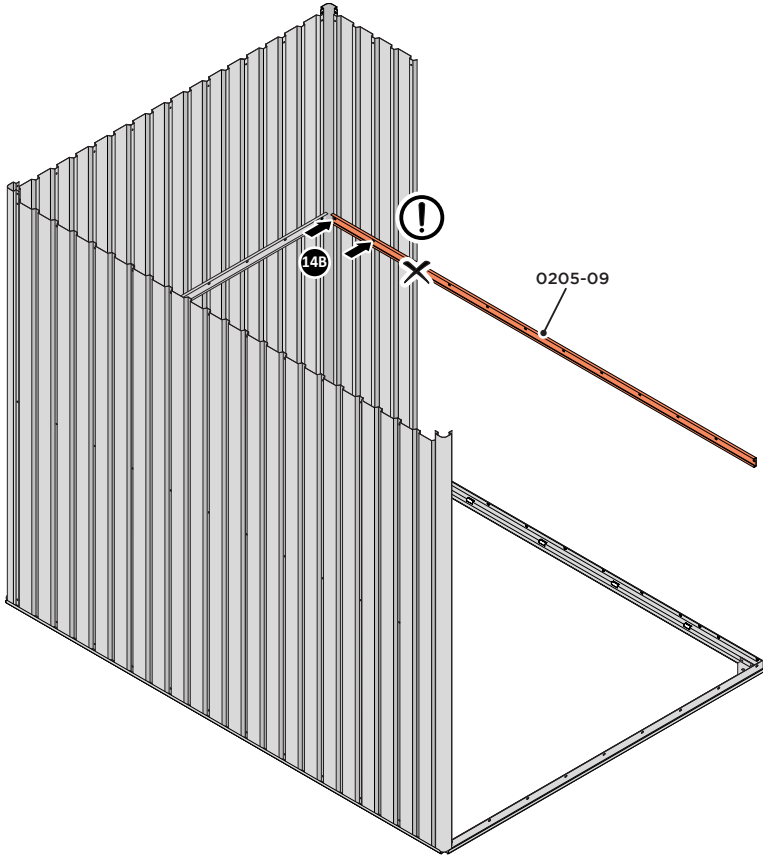

14A LOCATE AND LOOSELY ATTACH MID CENTRE BRACE 0205-09 AS SHOWN AT X3 LOCATIONS INDICATED ABOVE.

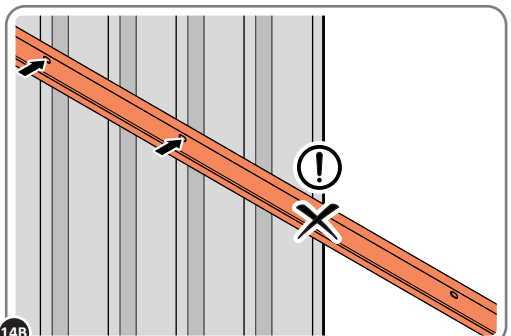

14B LOOSELY ATTACH AT LOCATIONS INDICATED ONLY.
IMPORTANT: DO NOT SECURE AT OUTER FIXING POINT INDICATED.

Assembly Guide

ASSEMBLY STAGE 15

LOCATE AND LOOSELY ATTACH WALL PANEL 0205-12 (1850 x 625mm).

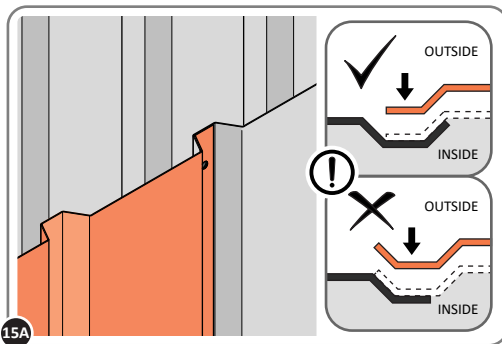
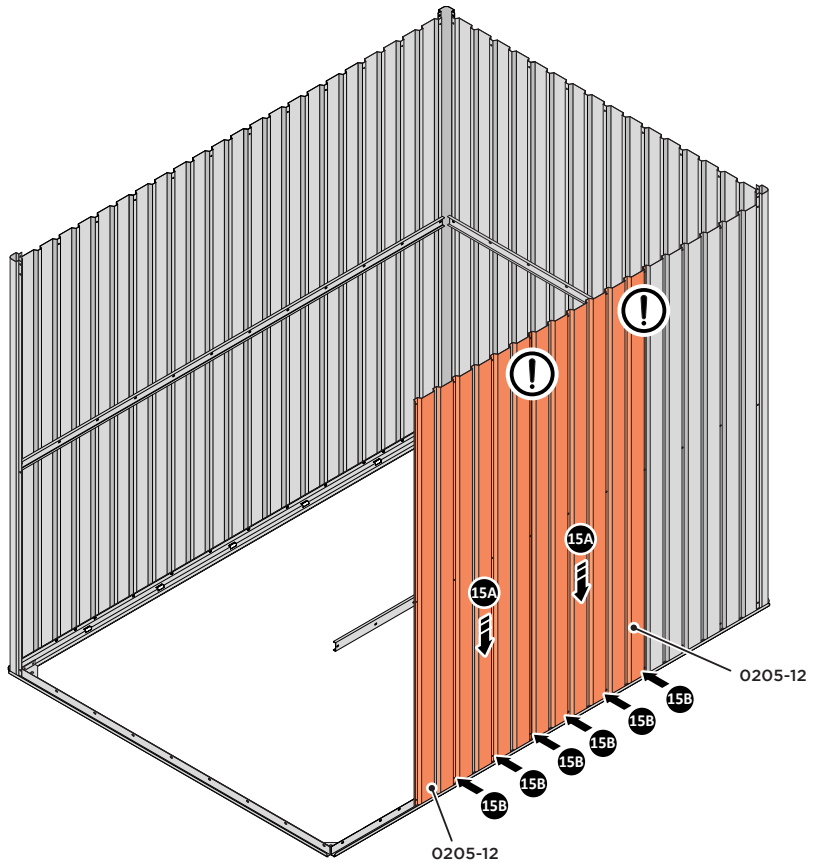

15A
LOCATE WALL PANEL 0205-12 INTO POSITION AS SHOWN ABOVE.
IMPORTANT: ENSURE PANEL IS IN THE CORRECT ORIENTATION.

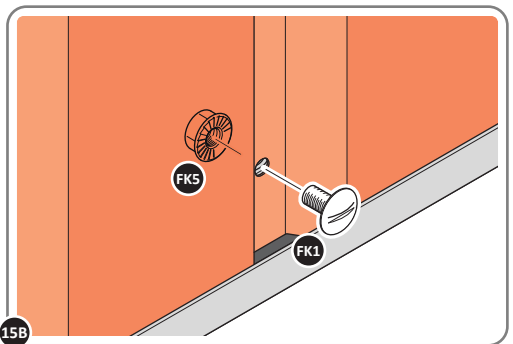

15B
LOOSELY ATTACH WALL PANEL AT x3 LOCATIONS INDICATED ONLY.
IMPORTANT: DO NOT SECURE ANY FIXING POINTS OTHER THAN THOSE INDICATED.

ASSEMBLY STAGE 16

LOCATE AND LOOSELY ATTACH WALL PANEL 0205-13 (1850 x 425mm).

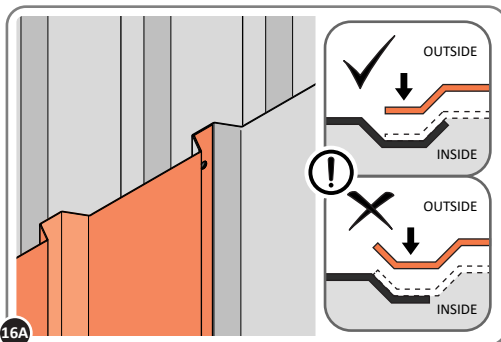
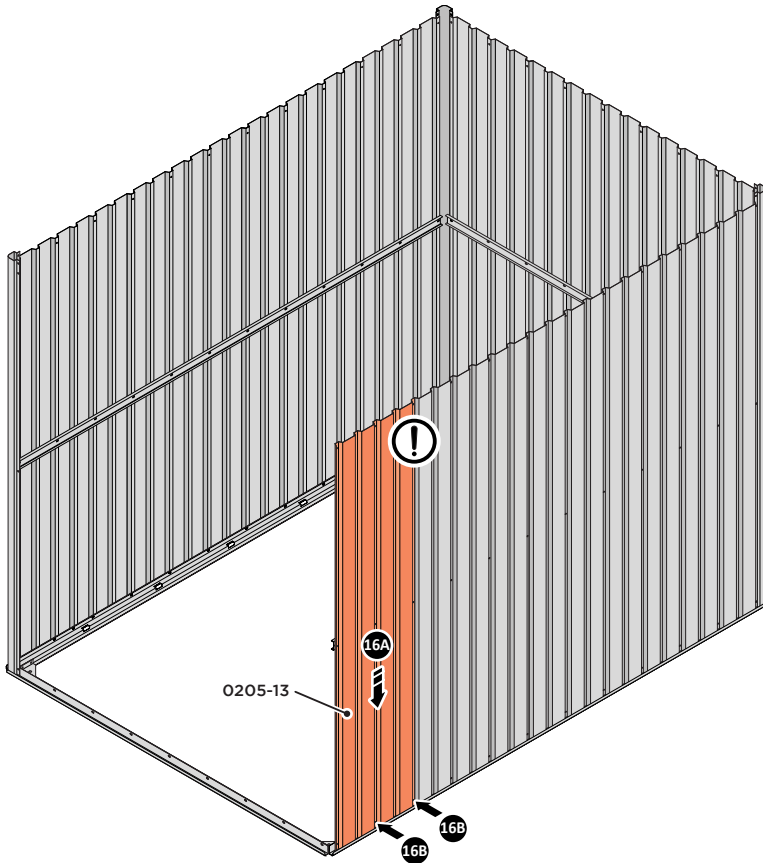

16A
LOCATE WALL PANEL 0205-12 INTO POSITION AS SHOWN ABOVE.
IMPORTANT: ENSURE PANEL IS IN THE CORRECT ORIENTATION.

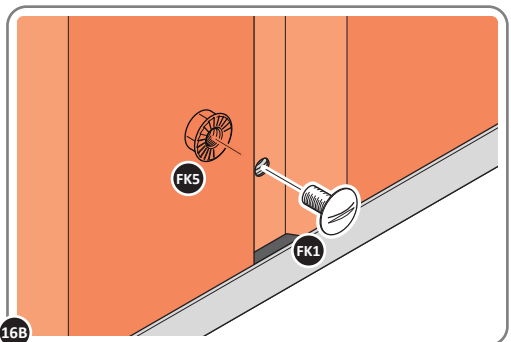

16B
LOOSELY ATTACH WALL PANEL AT x3 LOCATIONS INDICATED ONLY.
IMPORTANT: DO NOT SECURE ANY FIXING POINTS OTHER THAN THOSE INDICATED.

ASSEMBLY STAGE 17

LOCATE AND LOOSELY ATTACH CORNER POST 0205-14.

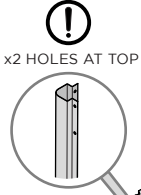

x2 HOLES AT TOP

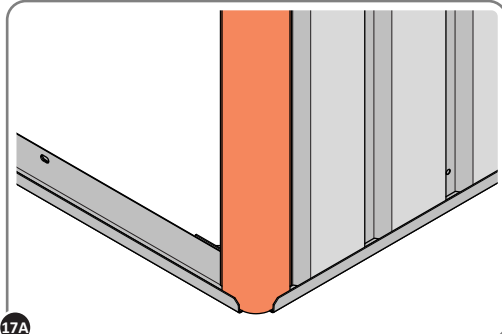
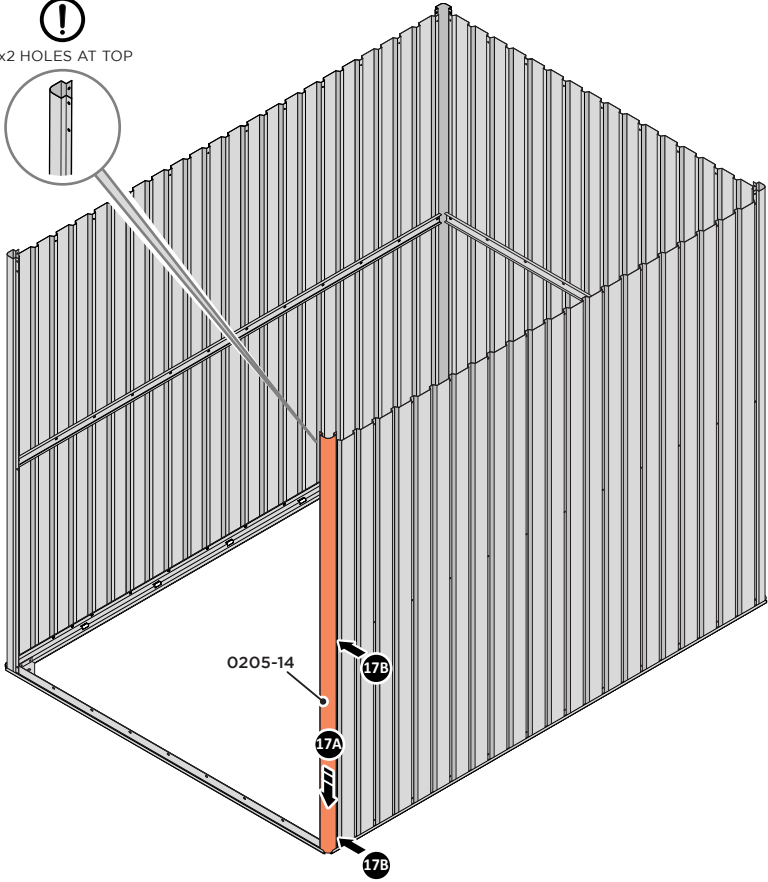

17A

LOCATE CORNER POST 0205-14 AS SHOWN ABOVE.

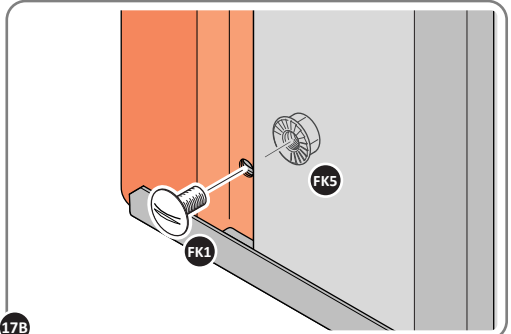

17B

LOOSELY ATTACH CORNER POST AT x2 LOCATIONS INDICATED ONLY.
IMPORTANT: DO NOT SECURE AT UPPER FIXING POINT AT THIS STAGE.

Assembly Guide

ASSEMBLY STAGE 18

LOCATE AND LOOSELY ATTACH LEFT-HAND DOOR POST 0205-17.

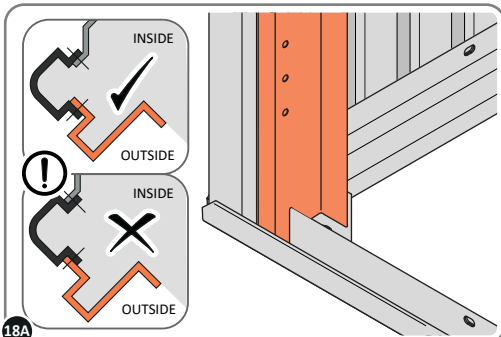
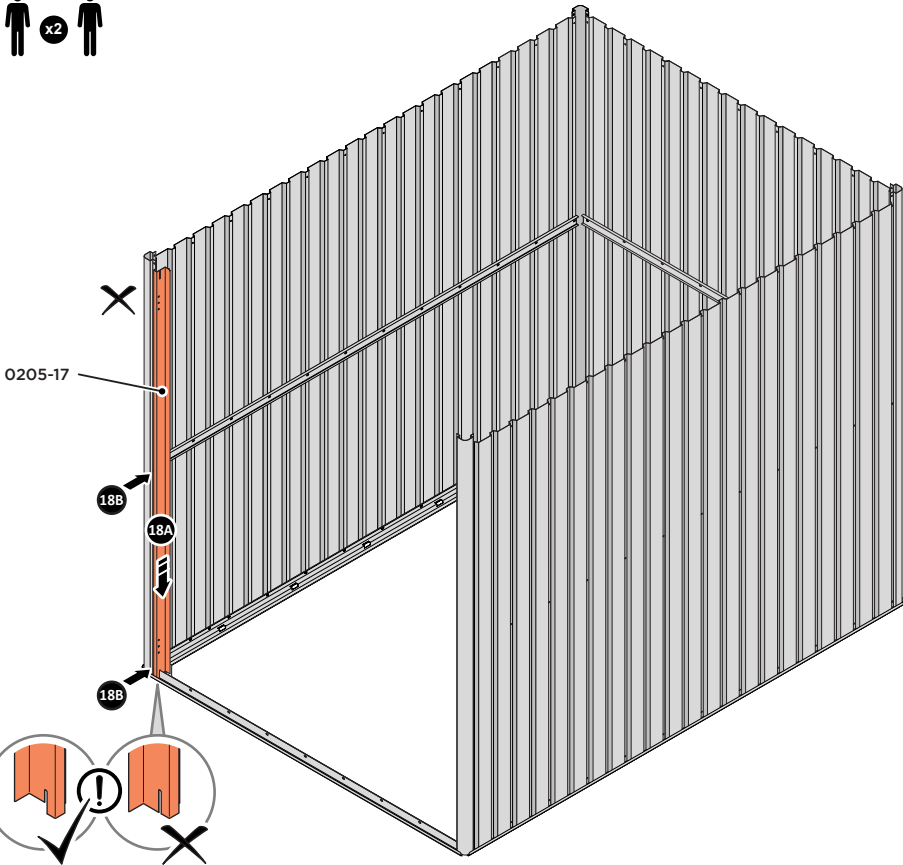

18A LOCATE LEFT-HAND DOOR POST 0205-17 AS SHOWN ABOVE.

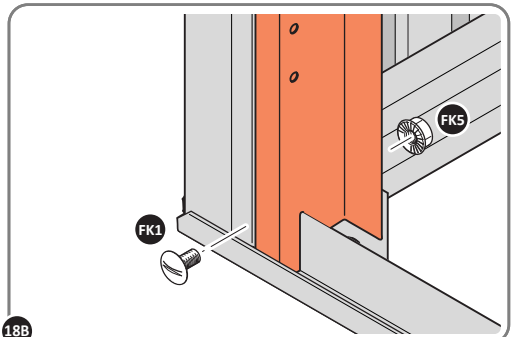

18B SECURE DOOR POST AT X2 LOCATIONS INDICATED.
IMPORTANT: DO NOT SECURE AT UPPER FIXING POINT AT THIS STAGE.

ASSEMBLY STAGE 19

LOCATE AND LOOSELY ATTACH RIGHT-HAND DOOR POST 0205-16.

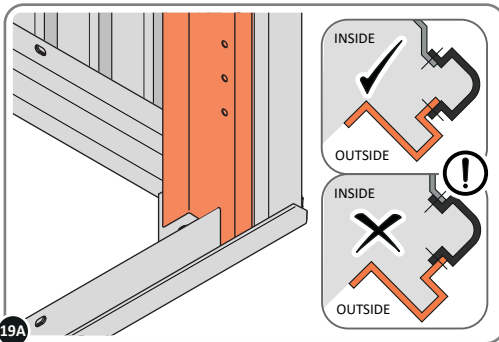
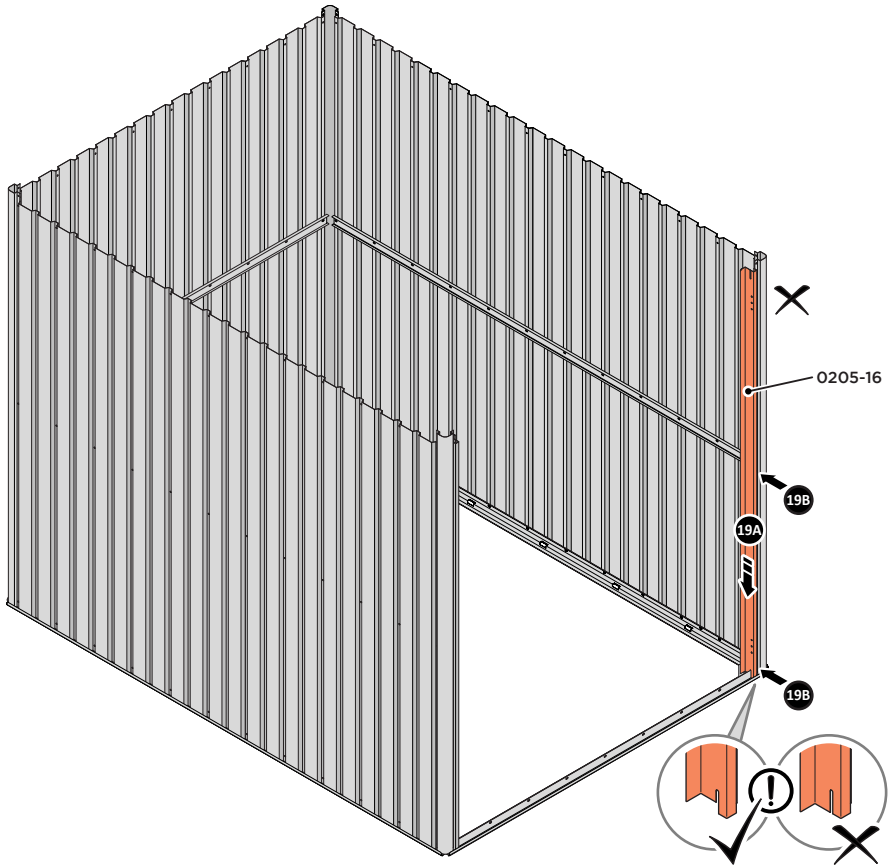

19A LOCATE RIGHT-HAND DOOR POST 0205-16 AS SHOWN ABOVE.

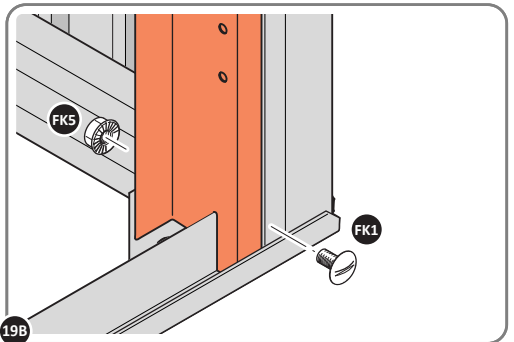

19B SECURE DOOR POST AT X2 LOCATIONS INDICATED.
IMPORTANT: DO NOT SECURE AT UPPER FIXING POINT AT THIS STAGE.

Assembly Guide

ASSEMBLY STAGE 20

LOCATE AND LOOSELY ATTACH SHORT ROOF RAIL 0213-02.

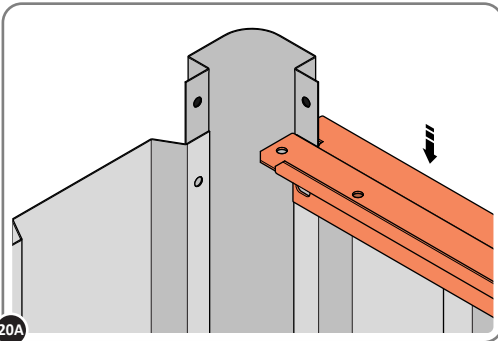
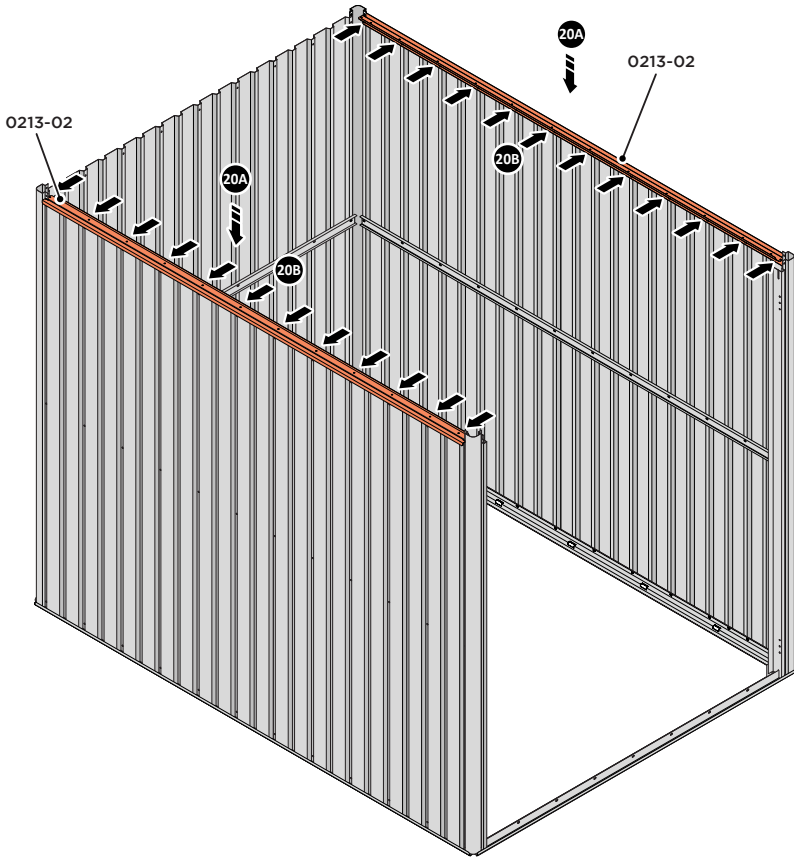

20A LOCATE SHORT ROOF RAIL 0213-02 AS SHOWN ABOVE.

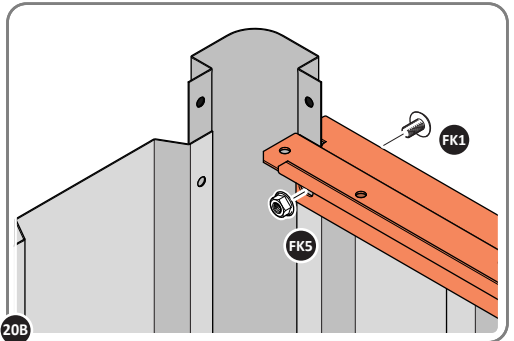

20B LOOSELY ATTACH AT X12 LOCATIONS INDICATED.

ASSEMBLY STAGE 21

LOCATE AND LOOSELY ATTACH LONG ROOF RAIL 0215-02.

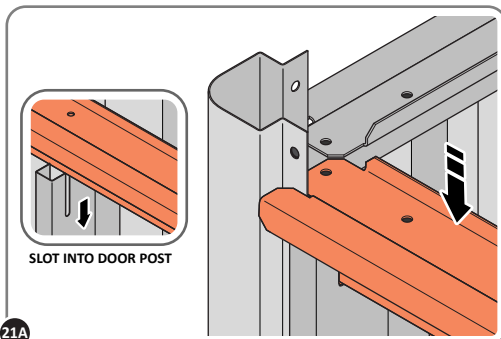
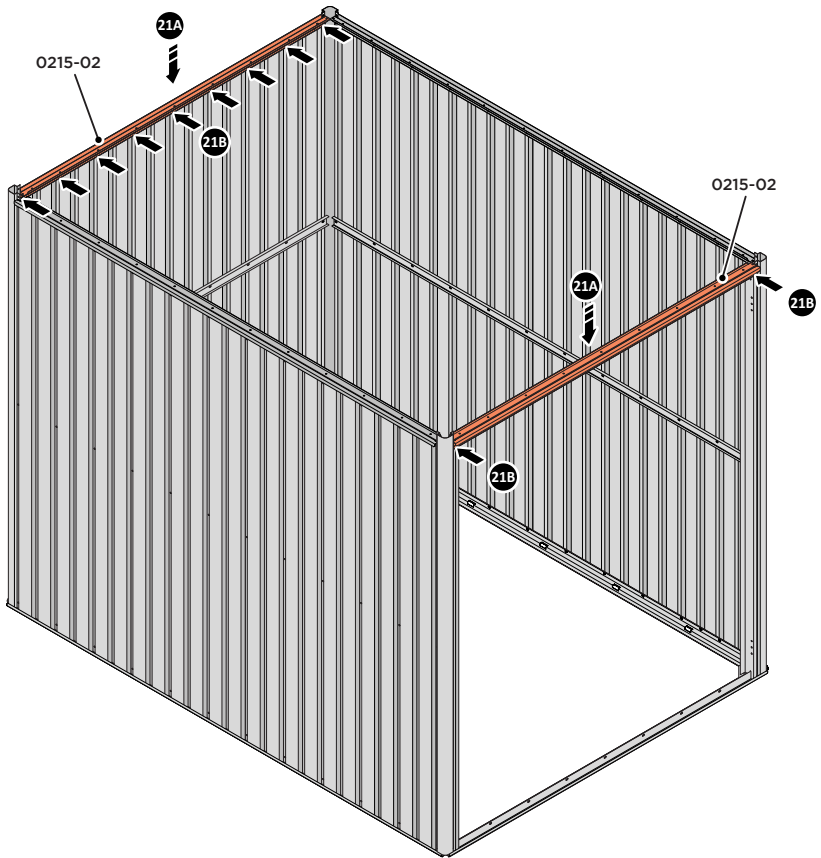

21A LOCATE LONG TOP RAIL 0215-02 AS SHOWN ABOVE.

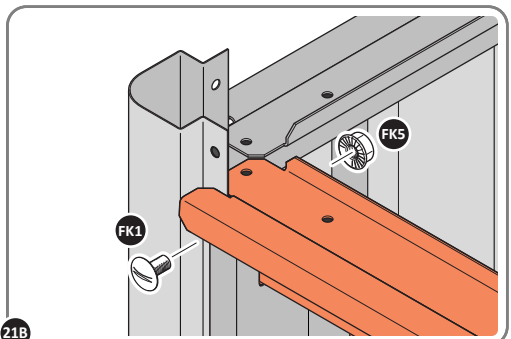

21B LOOSELY ATTACH AT LOCATIONS INDICATED.

ASSEMBLY STAGE 22

LOCATE GROUND ANCHOR BRACKETS 0205-57.

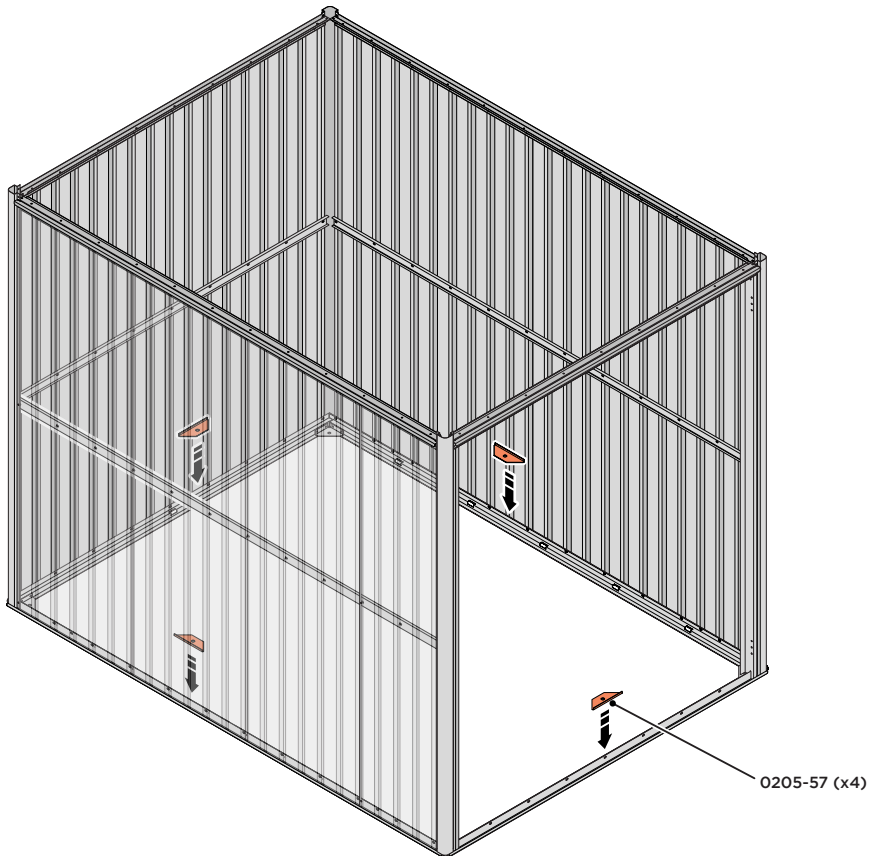

! THESE BRACKETS ARE SECURED USING GROUND ANCHOR KIT ONCE THE SHED WALL PANELS ARE FULLY ASSEMBLED (SEE PAGE 11) !

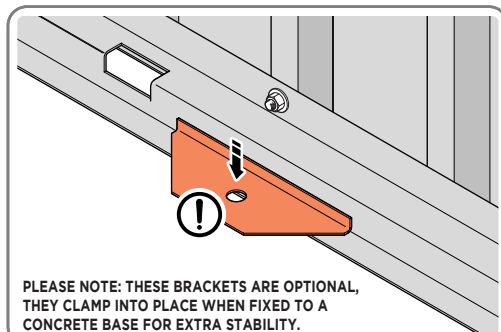

LOCATE x4 GROUND ANCHOR BRACKETS 0205-57 AS SHOWN ABOVE, THESE ALLOW FOR FIXING TO A CONCRETE BASE AT A LATER STAGE IF DESIRED.

ASSEMBLY STAGE 23

LOCATE AND SECURE DOOR STRIP 0205-74.

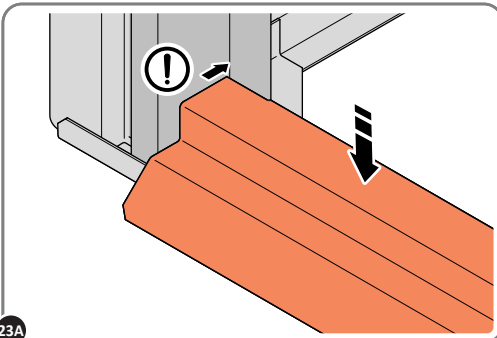
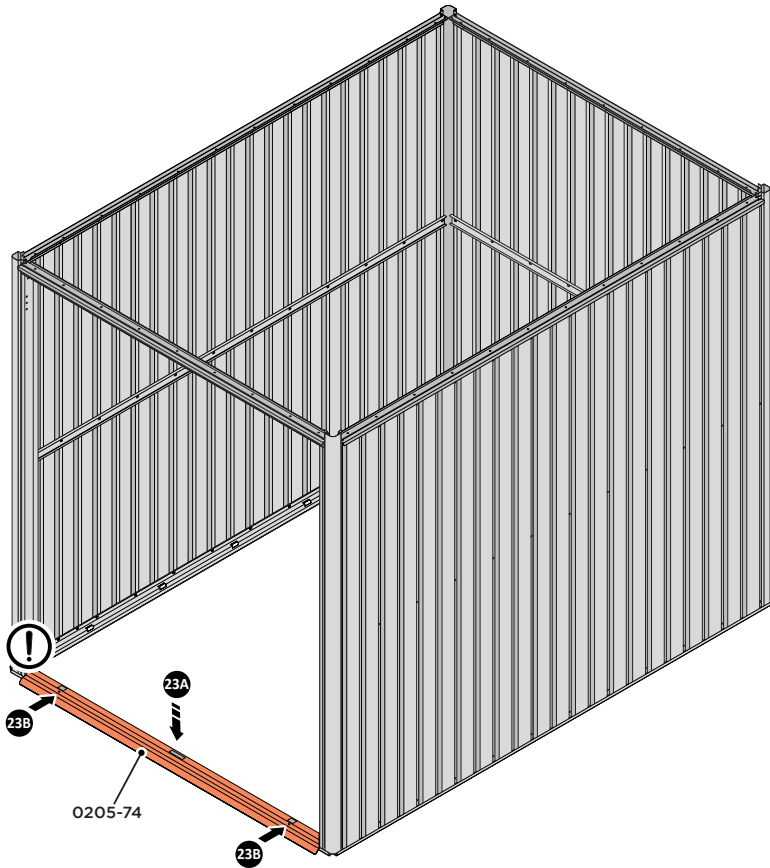

23A
LOCATE DOOR STRIP 0205-74 AS SHOWN.
IMPORTANT: ENSURE DOOR STRIP IS PUSHED AGAINST DOOR POST RETURN.

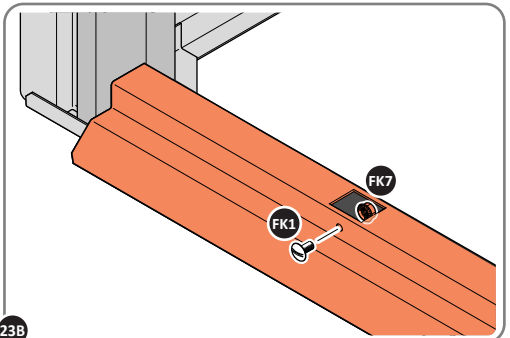

23B
SECURE DOOR STRIP ONTO FLOOR PANELS AT x2 LOCATIONS INDICATED, USE EXISTING HOLE AS A LOCATION GUIDE.

ASSEMBLY STAGE 24

LOCATE AND SECURE ROOF INFILL SIDE 0256-05.

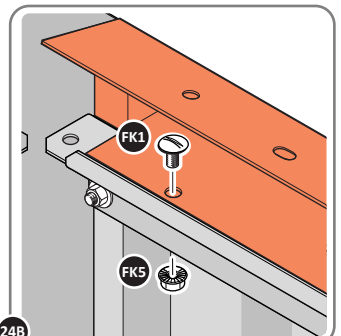
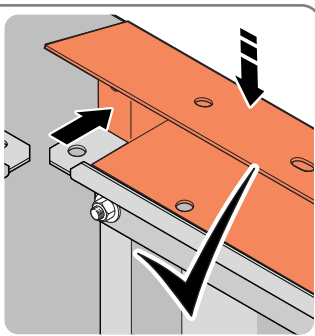
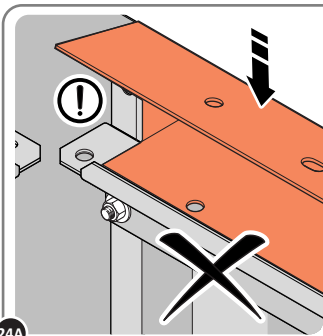
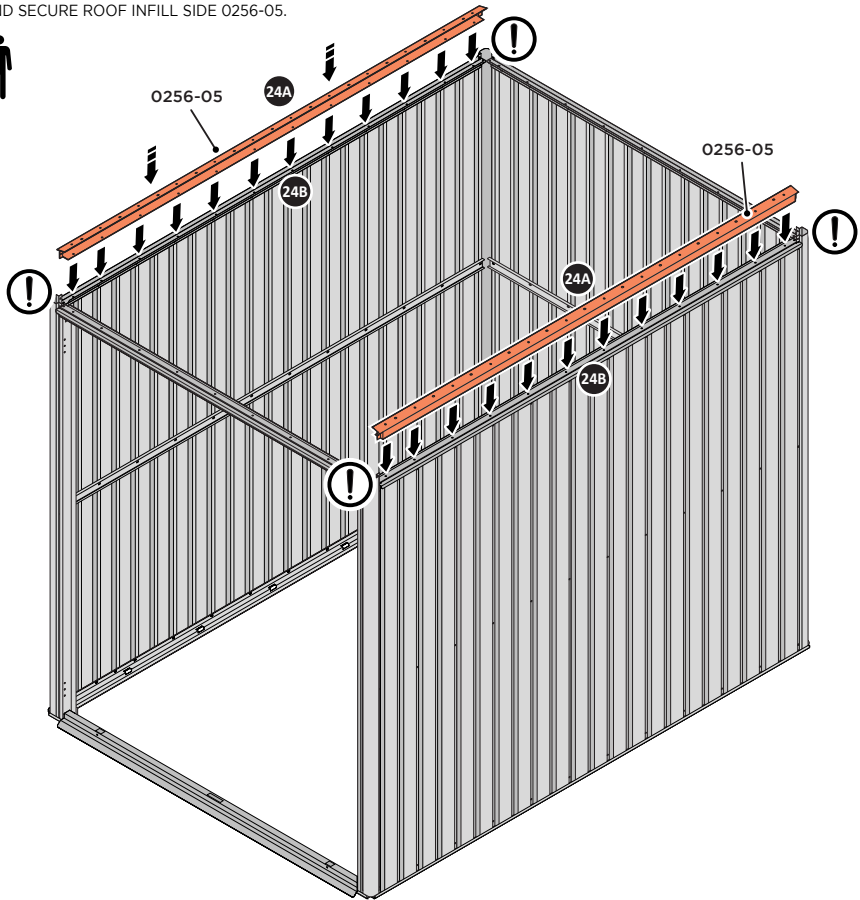

LOCATE AND SECURE ROOF SIDE INFILL 0256-05 AT x12 LOCATIONS INDICATED AS SHOWN ABOVE ON EACH SIDE.
IMPORTANT: ENSURE ROOF SIDE INFILL 0256-05 IS FITTED ON THE INSIDE AND NOT ON THE OUTSIDE AS ILLUSTRATED ABOVE.

Assembly Guide

ASSEMBLY STAGE 25

LOCATE AND SECURE ROOF FRONT INFILL 0244-15.

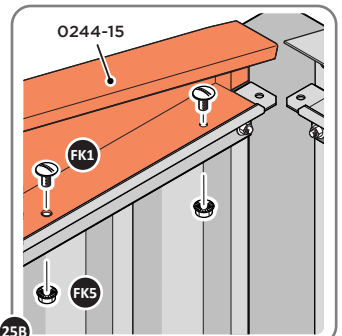
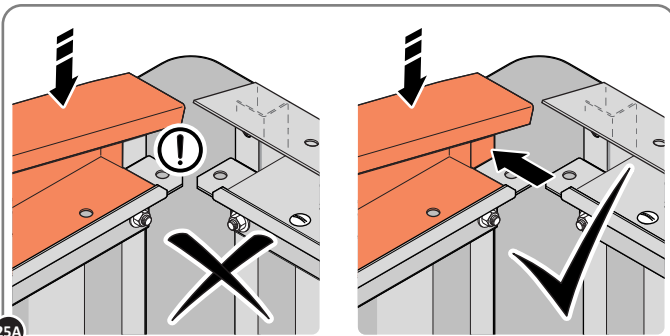
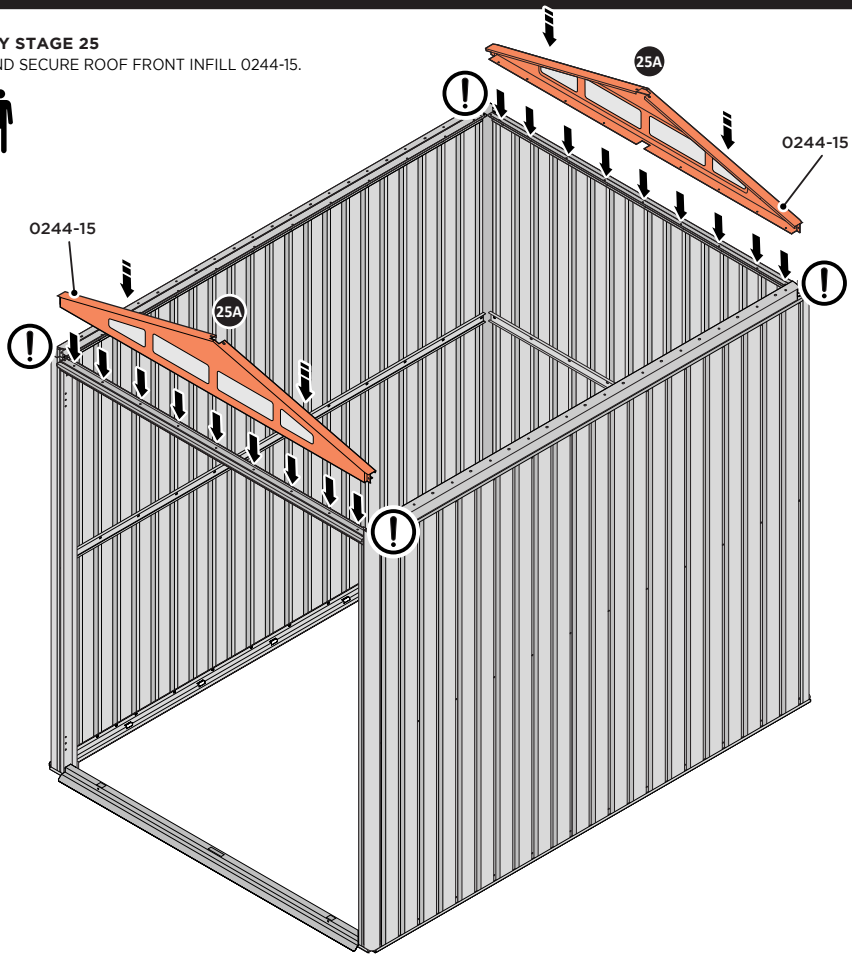

LOCATE AND SECURE WINDOW ASSEMBLY 0244-15 AT LOCATIONS INDICATED AS SHOWN ABOVE.

IMPORTANT: ENSURE WINDOW ASSEMBLY 0244-15 IS FITTED ON THE INSIDE AND NOT ON THE OUTSIDE AS ILLUSTRATED ABOVE.

Assembly Guide

ASSEMBLY STAGE 26

LOCATE AND EACH CORNER BRACKET 0203-15 TO ROOF INFILL AT FOUR LOCATIONS.

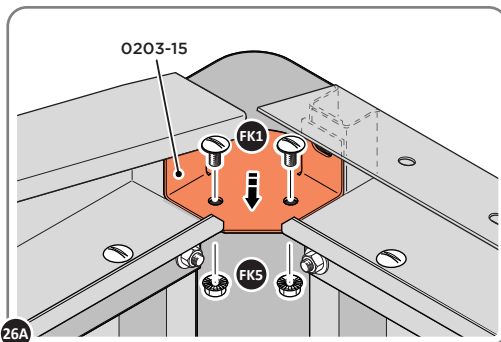
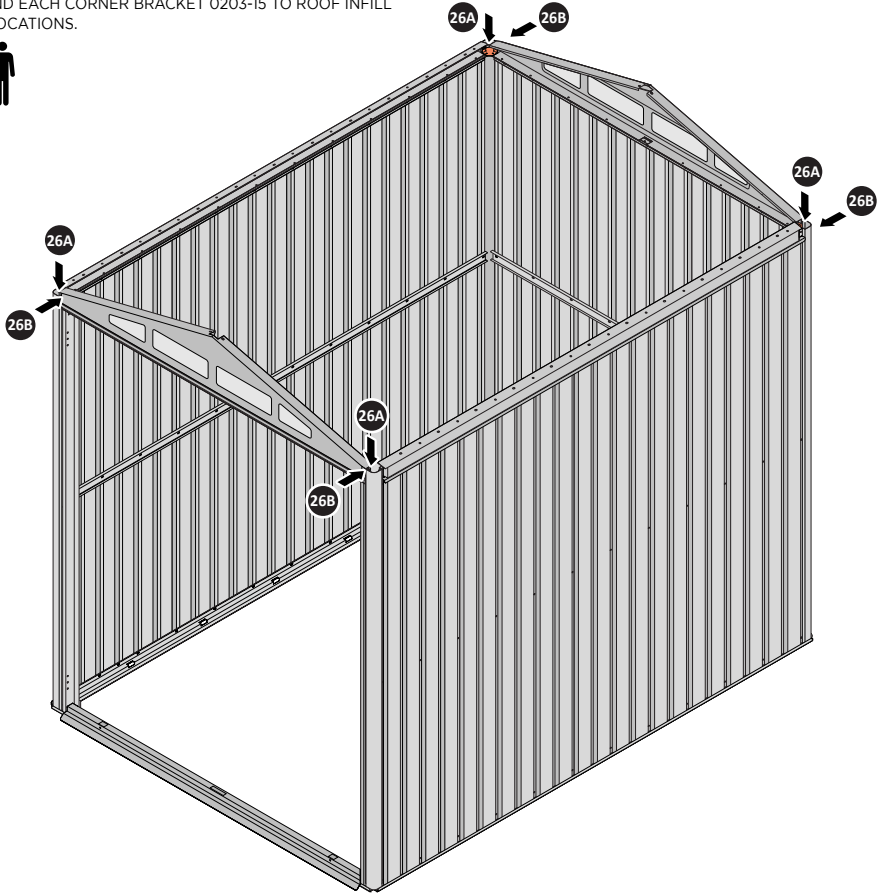

SECURE EACH CORNER BRACKET 0203-15 TO ROOF INFILLS AT LOCATIONS INDICATED AS SHOWN ABOVE.

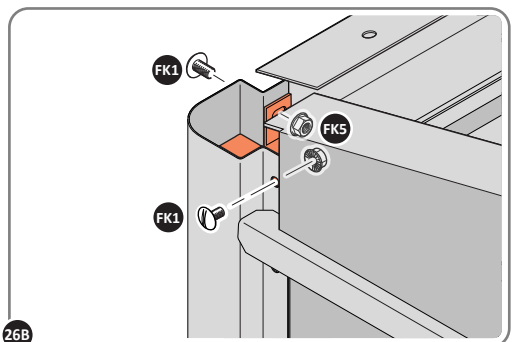

SECURE EACH CORNER BRACKET 0203-15 TO ROOF INFILLS AT LOCATIONS INDICATED AS SHOWN ABOVE.

ASSEMBLY STAGE 27

LOCATE AND SECURE ROOF SUPPORTS 0244-03.

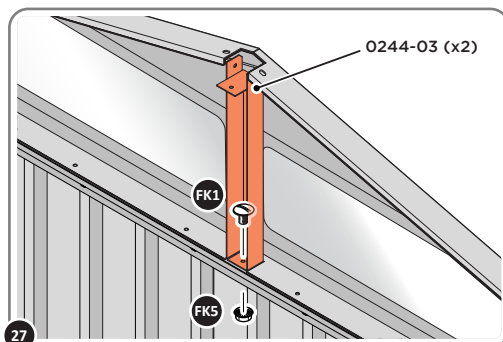
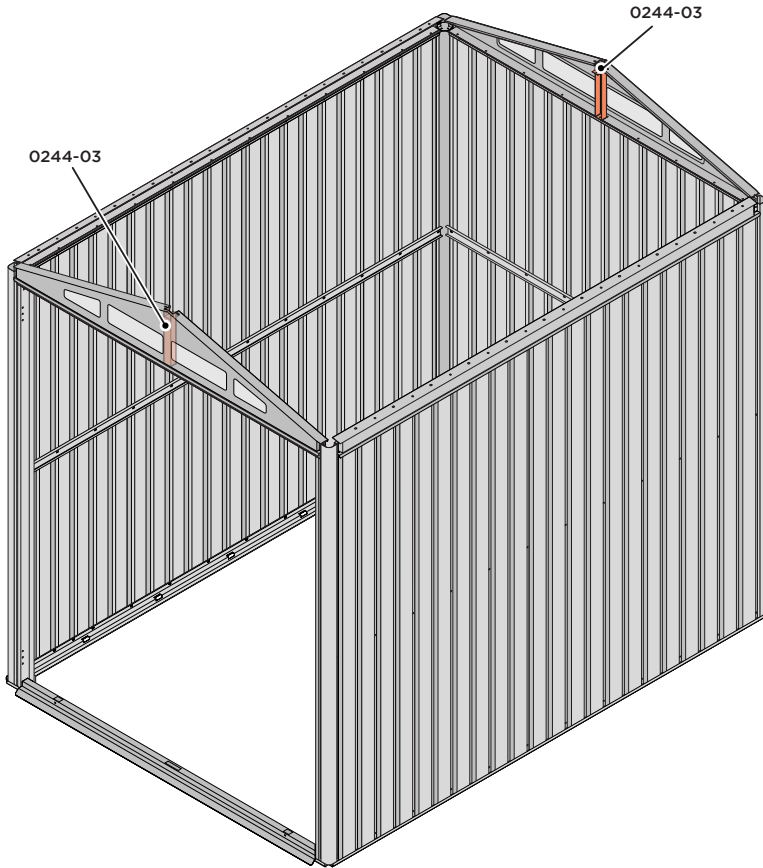

27 LOCATE AND SECURE LONG ROOF SUPPORT 0244-03 AS SHOWN ABOVE.

Assembly Guide

ASSEMBLY STAGE 28

LOCATE AND SECURE ROOF CHANNEL ASSEMBLY 0256-01.

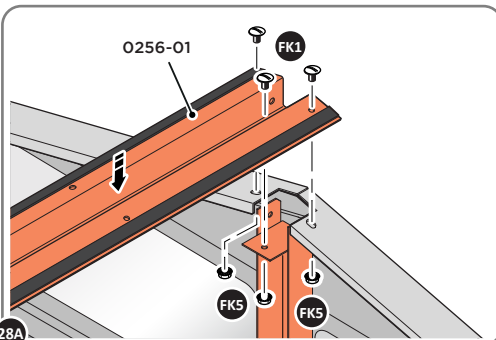
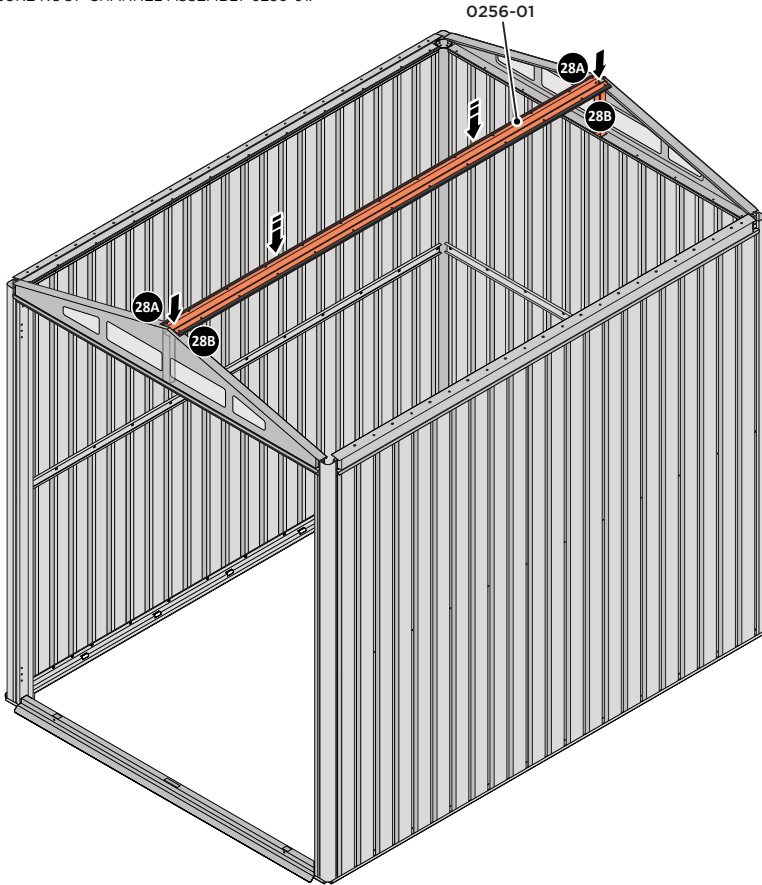

SLOT ROOF CHANNEL ASSEMBLY 0256-01 INTO ROOF SUPPORT. FIXING POINT (x3 EACH SIDE) USING FASTENERS DETAILED ABOVE.

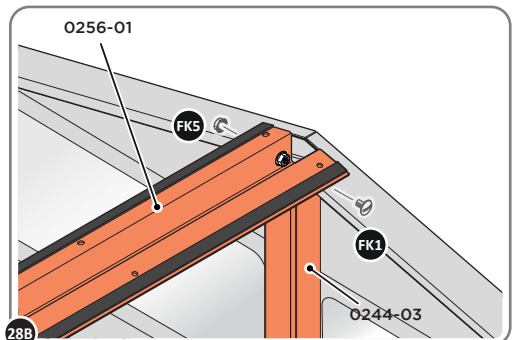

SECURE ROOF CHANNEL ASSEMBLY TO LONG ROOF SUPPORT 0244-03 FIXING POINT (x2 EACH SIDE) USING FASTENERS DETAILED ABOVE.

ASSEMBLY STAGE 29

LOCATE AND SECURE ROOF PANEL 0244-04.

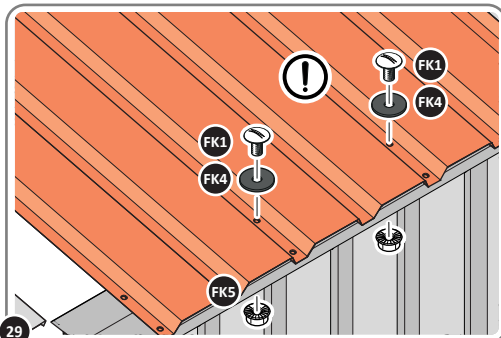
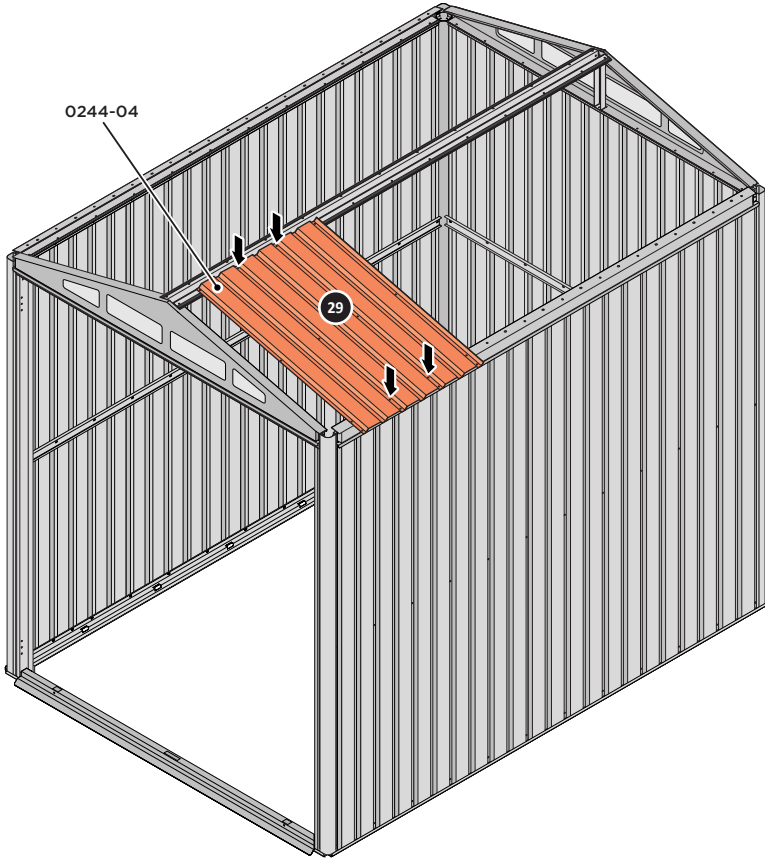

SECURE ROOF PANELS AT x4 LOCATIONS INDICATED USING TYPICAL FIXING METHOD.
IMPORTANT: ENSURE RUBBER WASHER FK4 IS LOCATED AS SHOWN.

Assembly Guide

ASSEMBLY STAGE 30

LOCATE AND SECURE ROOF PANEL SIDE 0244-06.

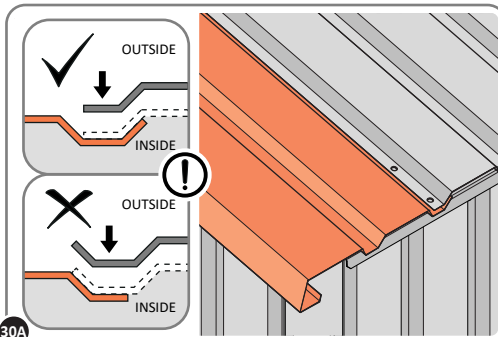
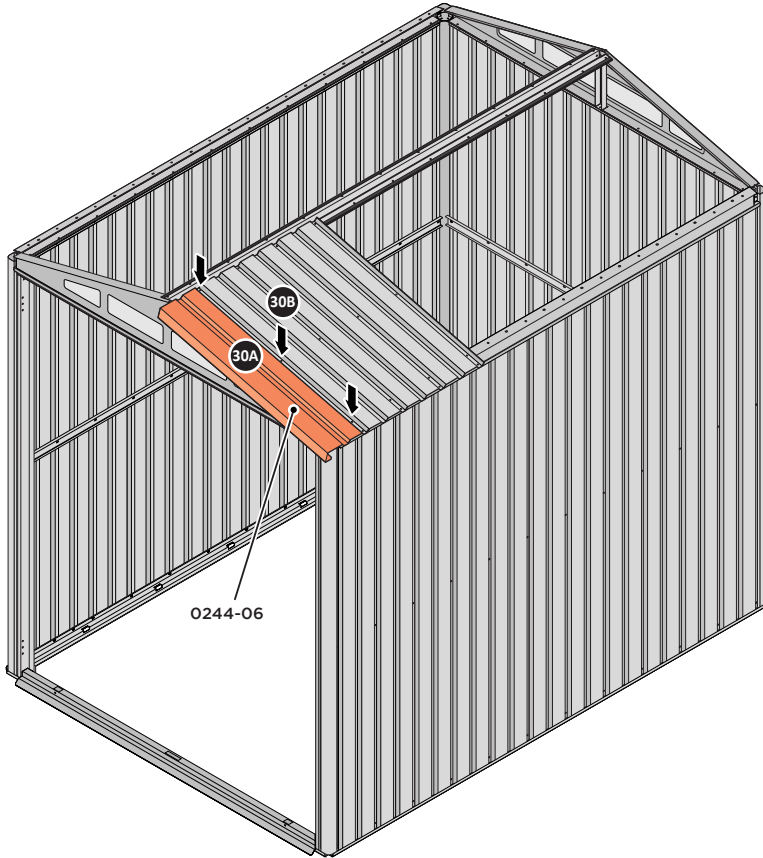

30A ALIGN AND OVERLAP ROOF PANEL 0244-06 WITH ROOF PANEL SIDE AS SHOWN.
IMPORTANT: ENSURE PANELS ALWAYS OVERLAP AS SHOWN.

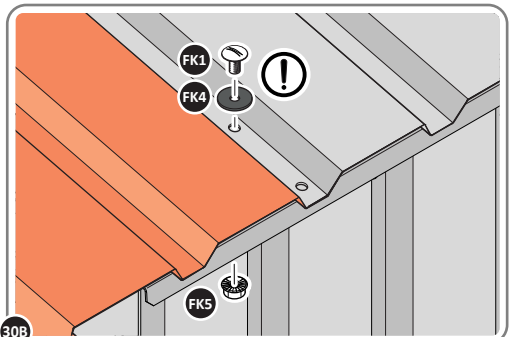

30B SECURE ROOF PANELS AT x3 LOCATIONS INDICATED USING TYPICAL FIXING METHOD.
IMPORTANT: ENSURE RUBBER WASHER FK4 IS LOCATED AS SHOWN.

ASSEMBLY STAGE 31

LOCATE AND SECURE ROOF PANELS 0244-04 & ROOF PANEL SMALL 0244-05.

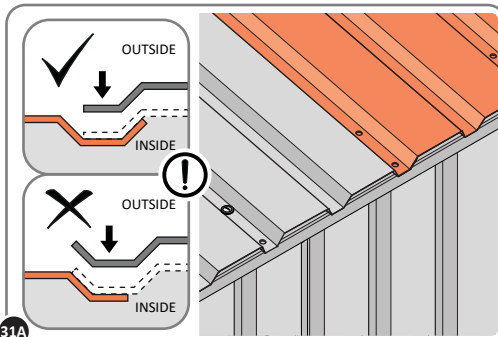
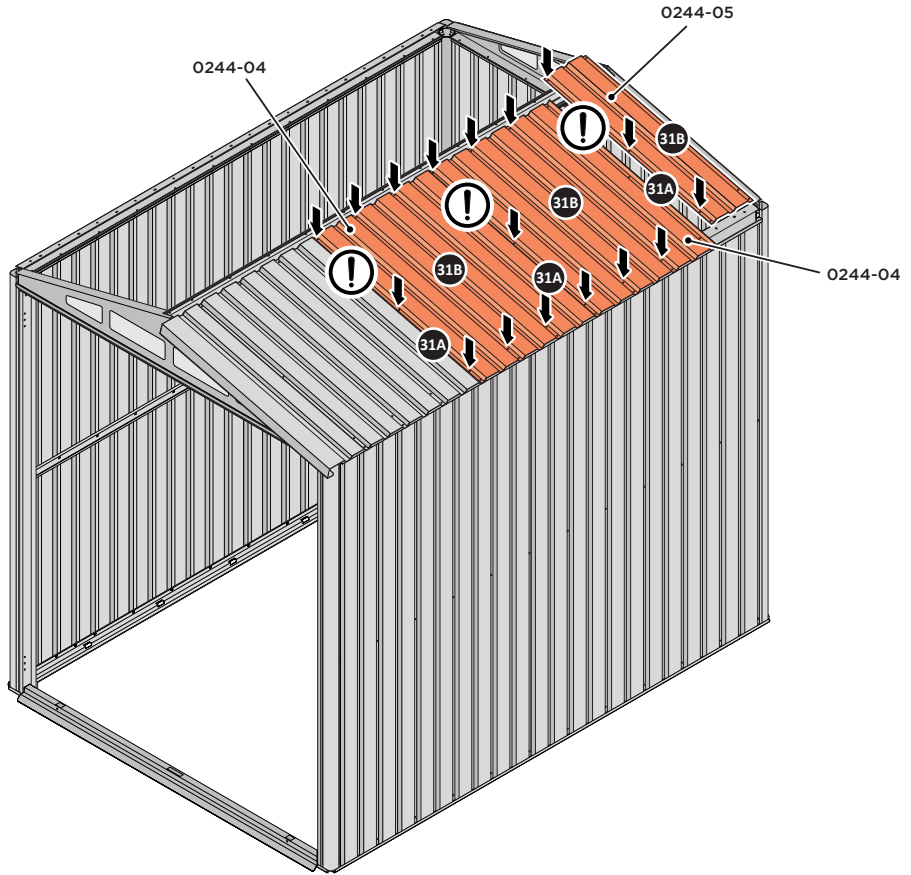

31A ALIGN AND OVERLAP ROOF PANEL WITH PREVIOUS ROOF PANEL.
IMPORTANT: ENSURE PANELS ALWAYS OVERLAP AS SHOWN.

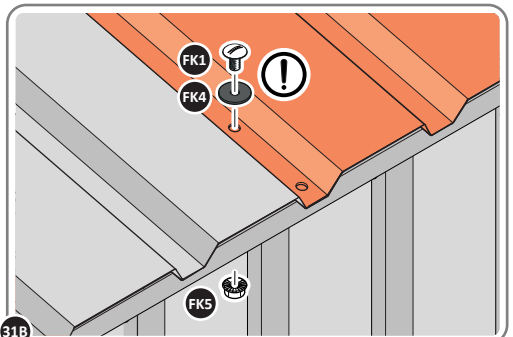

31B SECURE ROOF PANELS AT LOCATIONS INDICATED USING TYPICAL FIXING METHOD.
IMPORTANT: ENSURE RUBBER WASHER FK4 IS LOCATED AS SHOWN.

ASSEMBLY STAGE 32

LOCATE AND SECURE ROOF PANEL SIDE 0244-06.

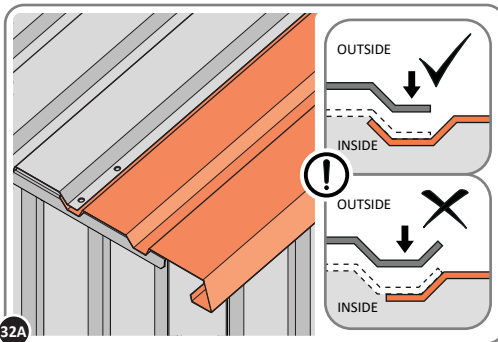
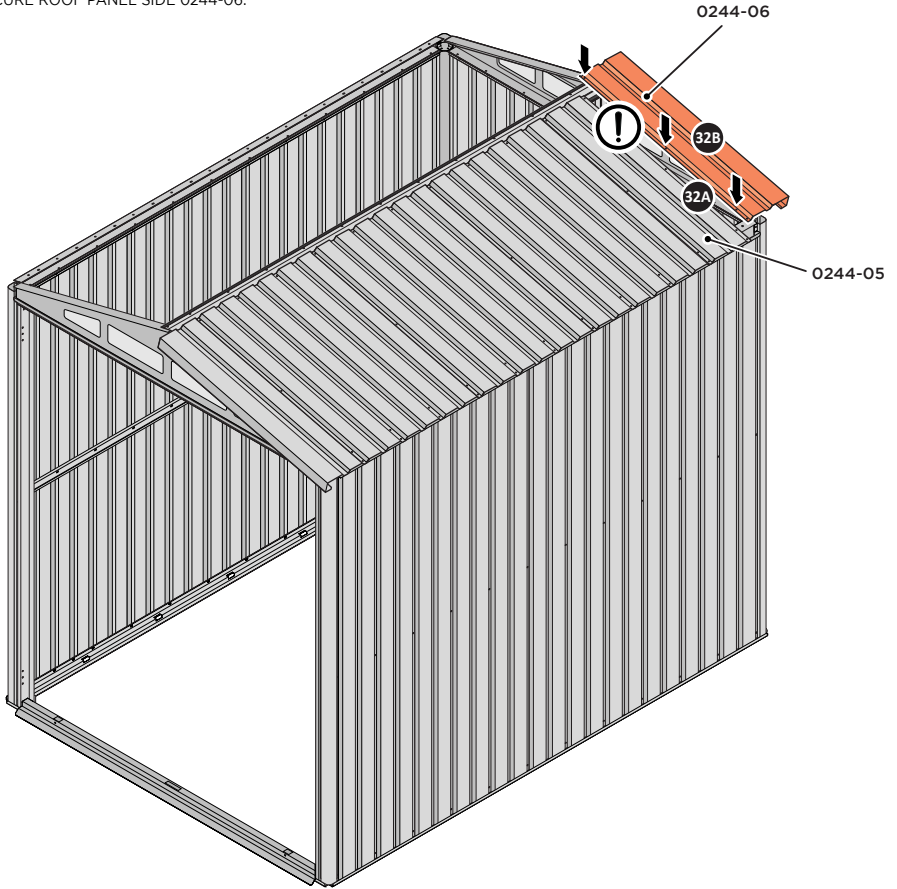

32A ALIGN AND OVERLAP ROOF PANEL 0244-06 WITH ROOF PANEL SIDE AS SHOWN.

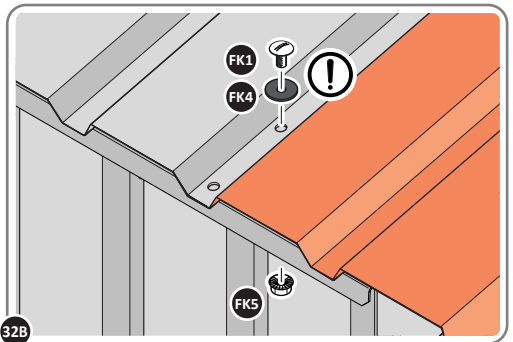

32B SECURE ROOF PANELS AT x 3 LOCATIONS INDICATED USING TYPICAL FIXING METHOD.

ASSEMBLY STAGE 33

LOCATE AND SECURE ROOF PANEL 0244-04.

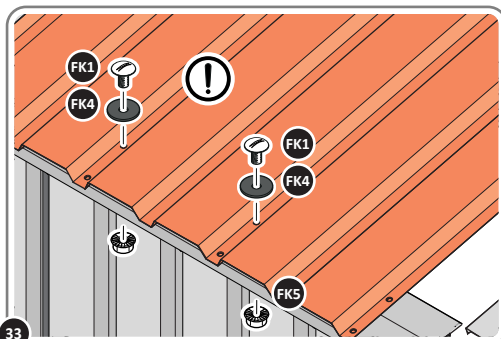
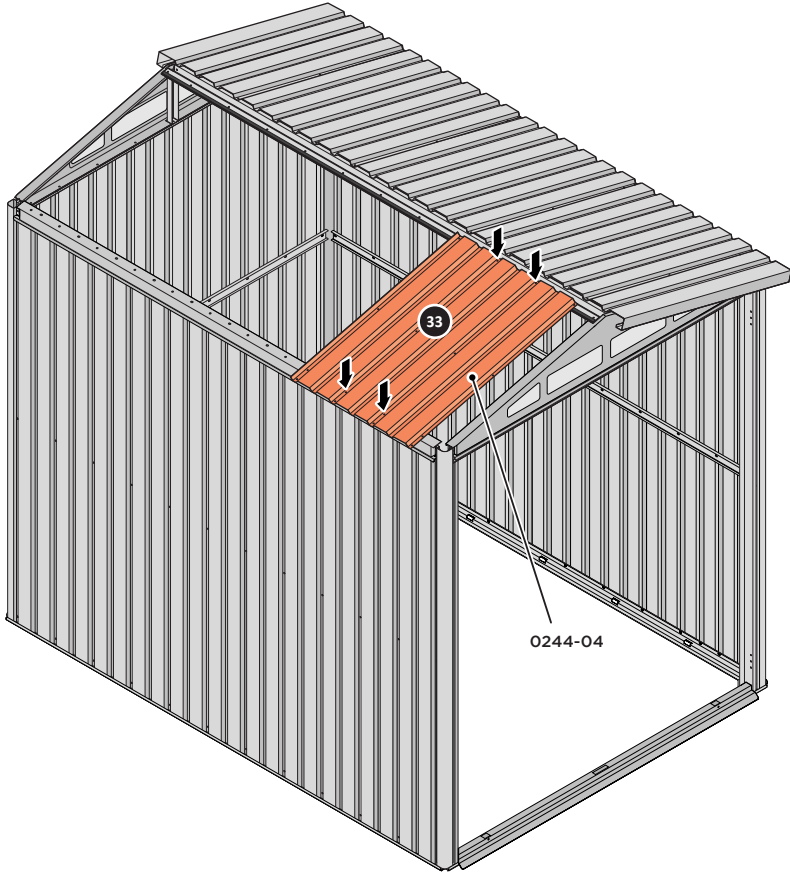

SECURE ROOF PANELS AT x4 LOCATIONS INDICATED USING TYPICAL FIXING METHOD.
IMPORTANT: ENSURE RUBBER WASHER FK4 IS LOCATED AS SHOWN.

ASSEMBLY STAGE 34

LOCATE AND SECURE ROOF PANEL SIDE 0244-06.

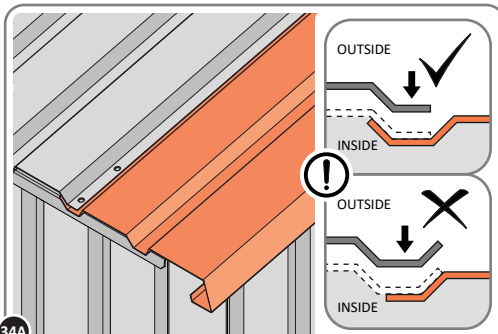
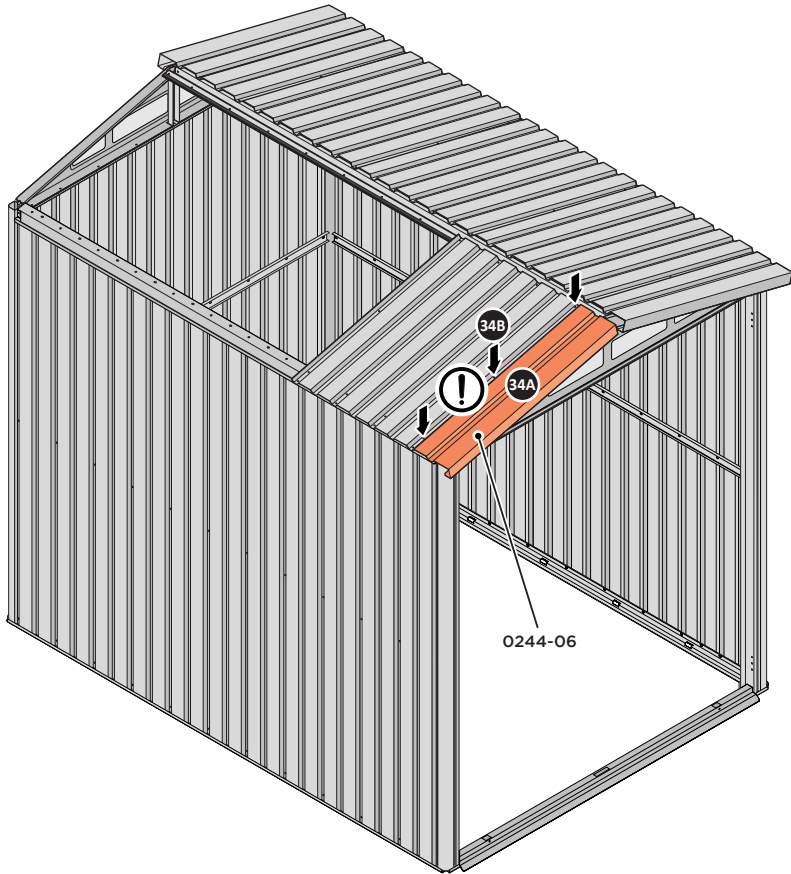

34A

ALIGN AND OVERLAP ROOF PANEL 0244-06 WITH ROOF PANEL SIDE AS SHOWN.
IMPORTANT: ENSURE PANELS ALWAYS OVERLAP AS SHOWN.

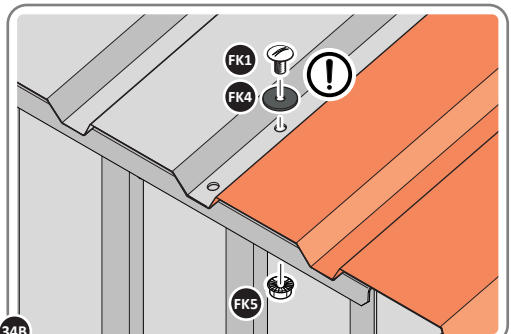

34B

SECURE ROOF PANELS AT x 3 LOCATIONS INDICATED USING TYPICAL FIXING METHOD.
IMPORTANT: ENSURE RUBBER WASHER FK4 IS LOCATED AS SHOWN.

ASSEMBLY STAGE 35

LOCATE AND SECURE ROOF PANELS 0244-04 & ROOF PANEL SMALL 0244-05.

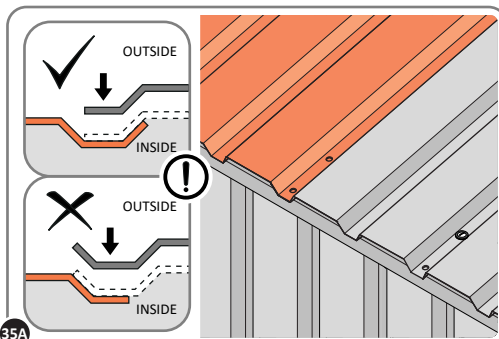
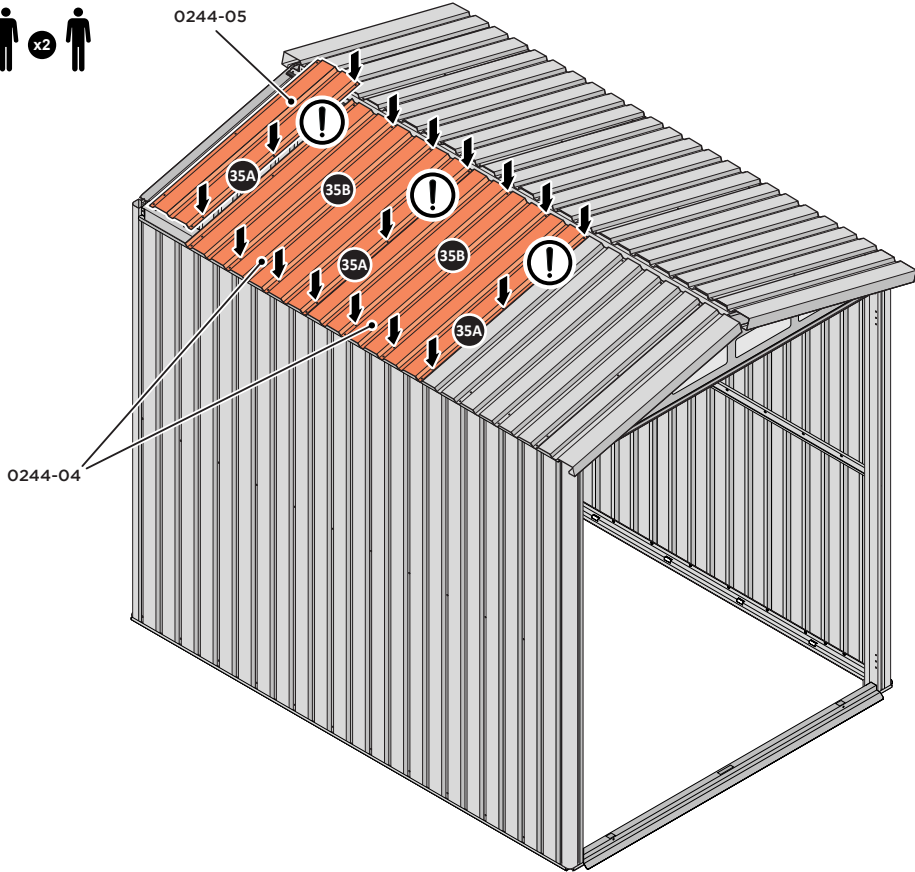

35A ALIGN AND OVERLAP ROOF PANEL WITH PREVIOUS ROOF PANEL.
IMPORTANT: ENSURE PANELS ALWAYS OVERLAP AS SHOWN.

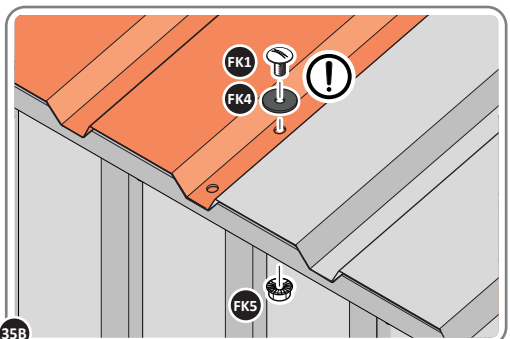

35B SECURE ROOF PANELS AT LOCATIONS INDICATED USING TYPICAL FIXING METHOD.
IMPORTANT: ENSURE RUBBER WASHER FK4 IS LOCATED AS SHOWN.

ASSEMBLY STAGE 36

LOCATE AND SECURE ROOF PANEL SIDE 0244-06.

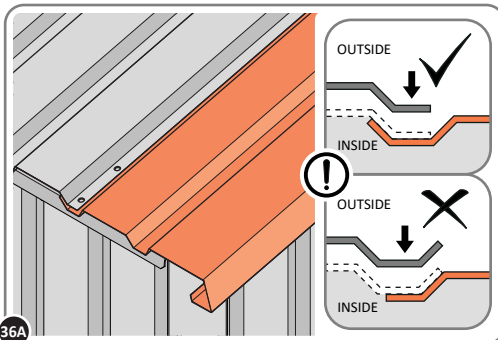
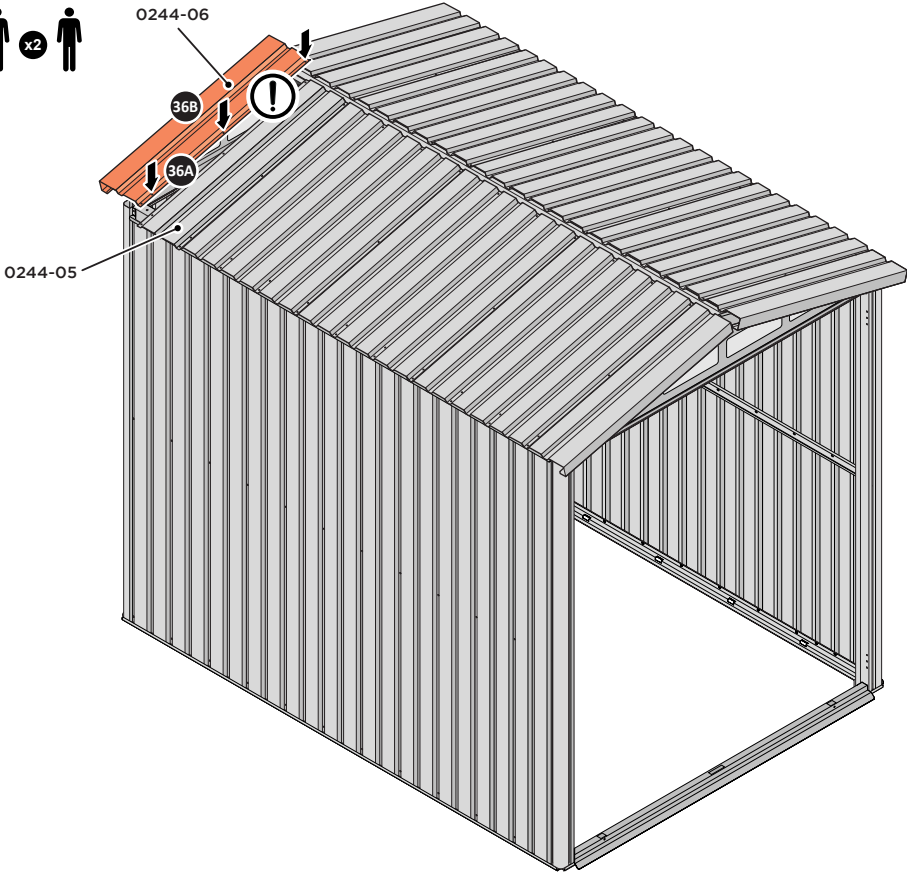

36A ALIGN AND OVERLAP ROOF PANEL 0244-06 WITH ROOF PANEL SIDE AS SHOWN. **IMPORTANT: ENSURE PANELS ALWAYS OVERLAP AS SHOWN.**

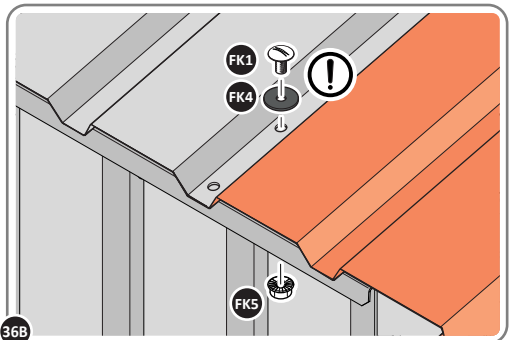

36B SECURE ROOF PANELS AT x 3 LOCATIONS INDICATED USING TYPICAL FIXING METHOD. **IMPORTANT: ENSURE RUBBER WASHER FK4 IS LOCATED AS SHOWN.**

ASSEMBLY STAGE 37

LOCATE AND SECURE ROOF RIDGE BRACKET 0244-16 TO ROOF RIDGE 0256-06. LOCATE AND SECURE ROOF RIDGE 0256-06 TO ROOF CHANNEL ASSEMBLY 0256-01.

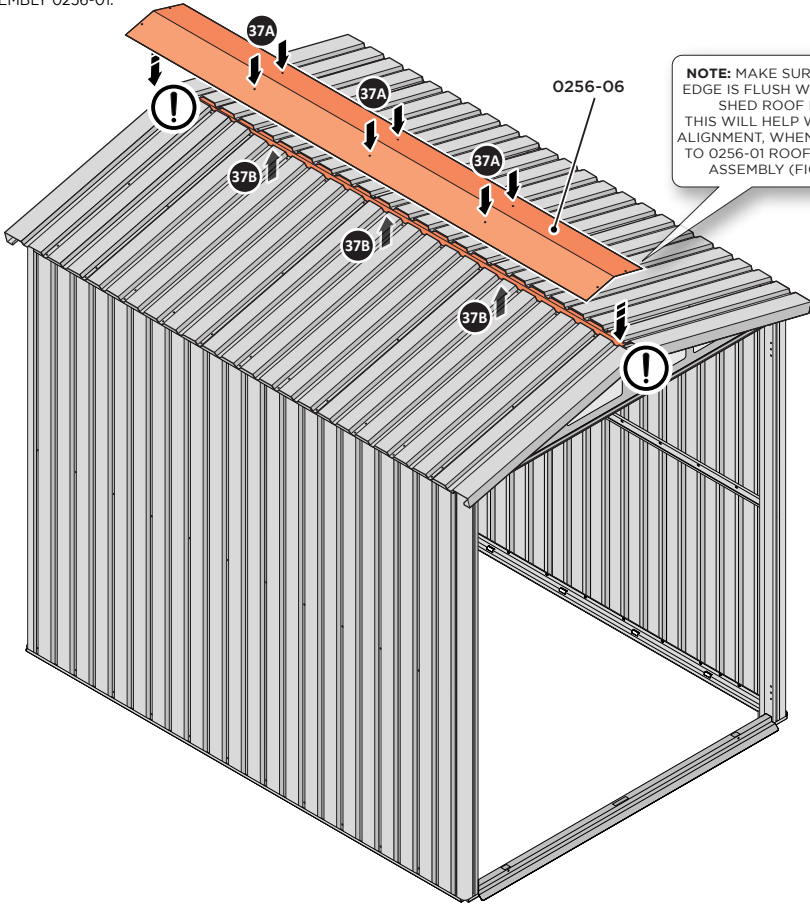

NOTE: MAKE SURE 0256-06 EDGE IS FLUSH WITH OUTER SHED ROOF EDGE. THIS WILL HELP WITH HOLE ALIGNMENT, WHEN SECURING TO 0256-01 ROOF CHANNEL ASSEMBLY (FIG.37B).

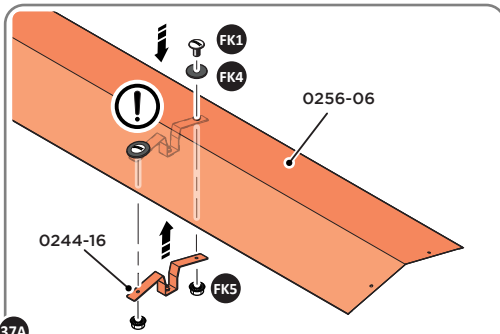

37A
SECURE ROOF RIDGE BRACKETS TO ROOF RIDGE AT x 3 LOCATIONS INDICATED. **IMPORTANT: ENSURE RUBBER WASHER FK4 IS LOCATED AS SHOWN.**

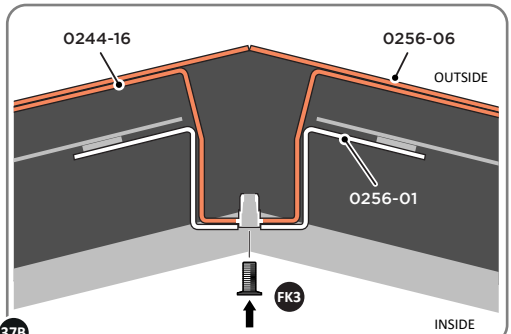

37B
NOTE: FROM INSIDE OF SHED SECURE ROOF RIDGE 0256-06 AT x3 LOCATIONS INDICATED USING TYPICAL FIXING METHOD.

ASSEMBLY STAGE 38

LOCATE AND SECURE ROOF RIDGE CAPS 0244-11 TO ROOF RIDGE 0244-12.

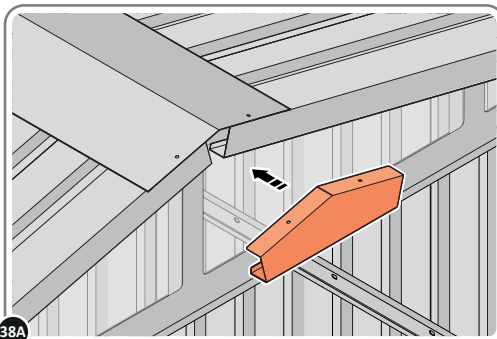
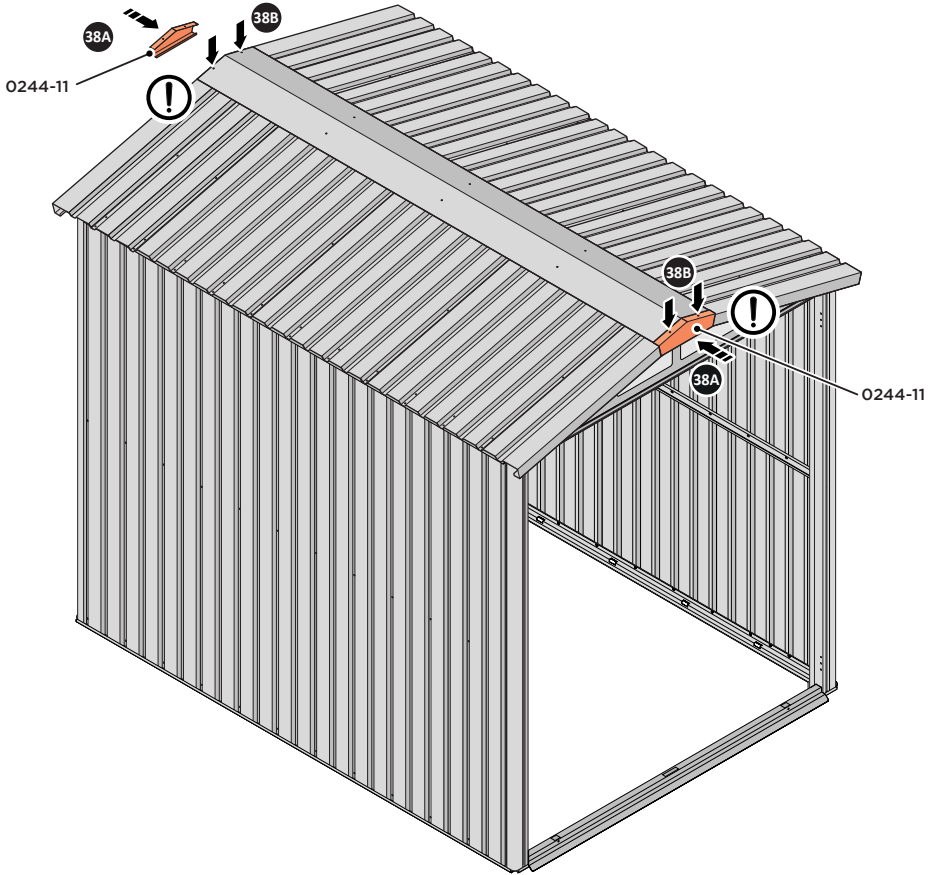

SLIDE RIDGE CAP 0244-11 INTO POSITION AT FRONT & REAR OF THE SHED ROOF.

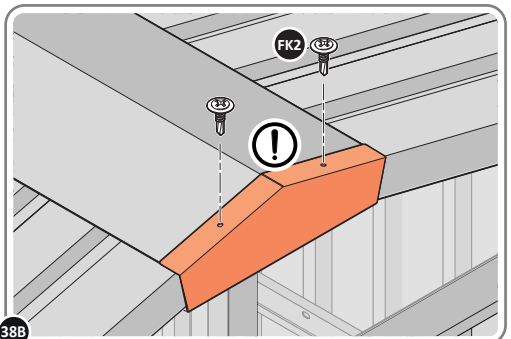

SECURE RIDGE CAP AT x4 LOCATIONS INDICATED USING TYPICAL FIXING METHOD. PLEASE NOTE: THE FIXING USED IS A SELF DRILLING COMPONENT.

ASSEMBLY STAGE 39

LOCATE AND SECURE ROOF GUTTER ASSEMBLY 0213-21.

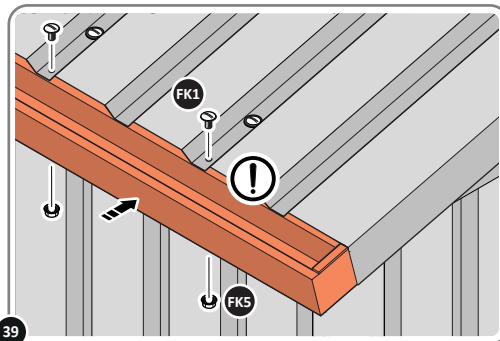
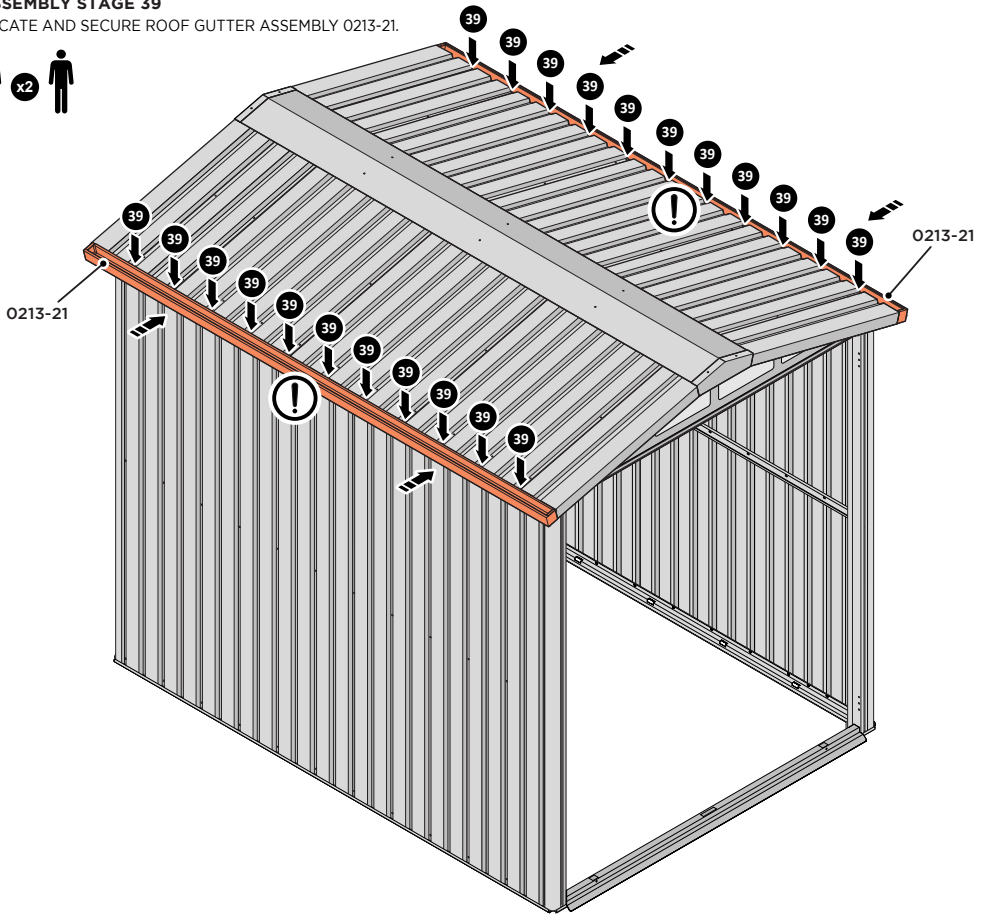

SLIDE AND SECURE ROOF GUTTER 0213-21 INTO POSITION AS SHOWN ABOVE.
IMPORTANT: ENSURE PANELS ALWAYS OVERLAP GUTTER AS SHOWN.

ASSEMBLY STAGE 40

LOCATE AND SECURE ROOF CAPS 0213-09.

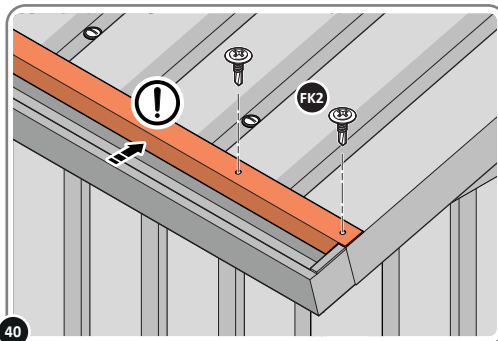
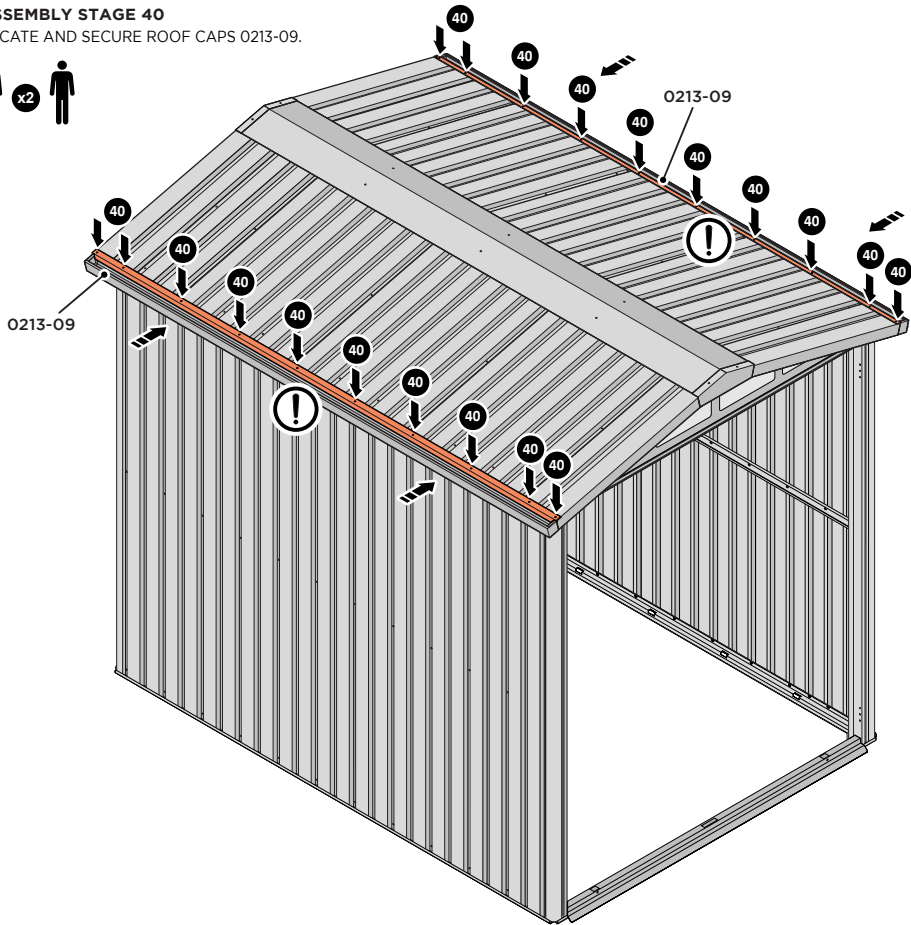

SLIDE AND SECURE ROOF CAP 0213-09 INTO POSITION AS SHOWN ABOVE.
PLEASE NOTE: THE FIXING USED IS A SELF DRILLING COMPONENT.

ASSEMBLY STAGE 41

DETERMINE WHICH SIDE DRAIN HOLE 0205-53 WILL BE LOCATED.

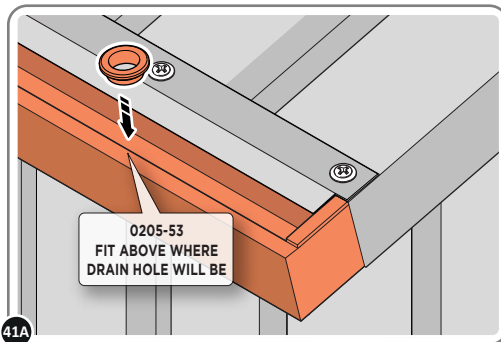
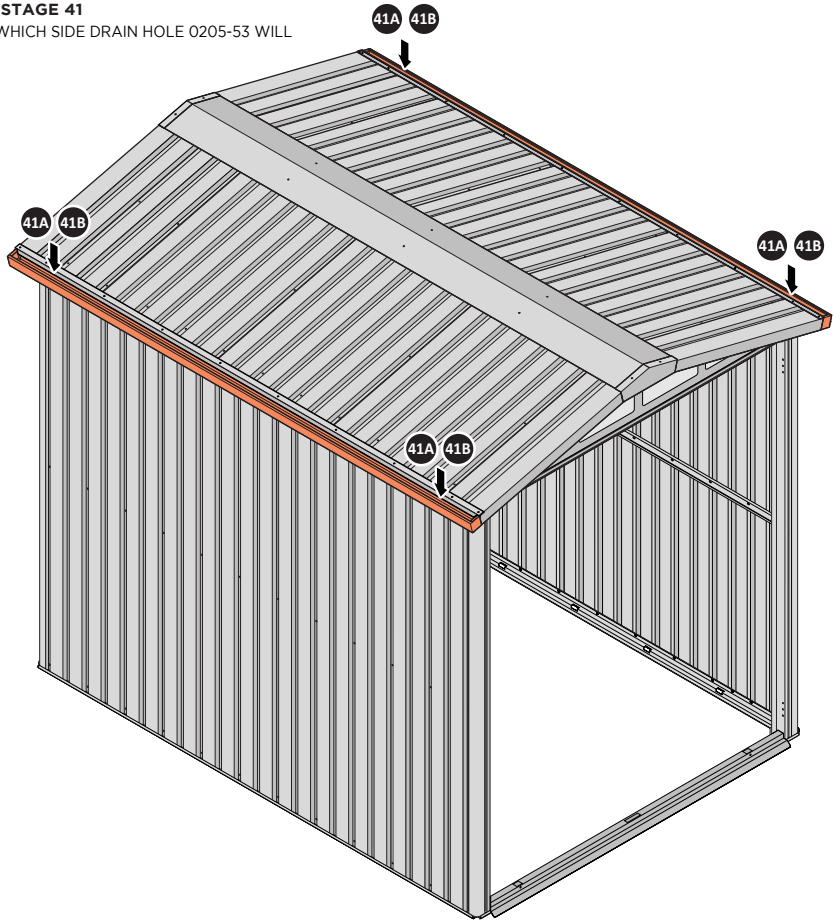

LOCATE AN OPEN GROMMET INTO THE ROOF GUTTER ABOVE WHERE THE DRAIN HOLE WILL BE LOCATED.

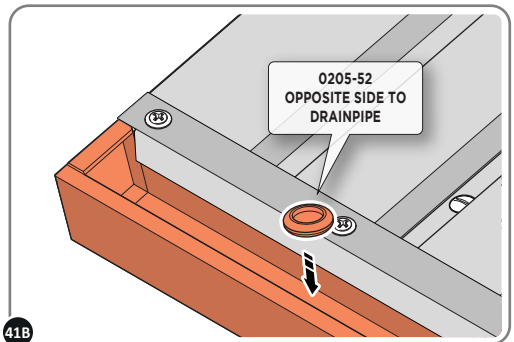

LOCATE CLOSED GROMMET INTO THE ROOF GUTTER ON THE OPPOSITE SIDE TO THE LOCATED DRAIN HOLE AS SHOWN ABOVE.

Assembly Guide

ASSEMBLY STAGE 42

LOCATE AND SECURE RIGHT-HAND DOOR ASSEMBLY 0205-36 FURNITURE.

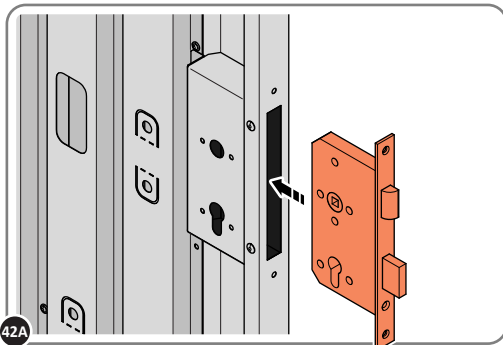
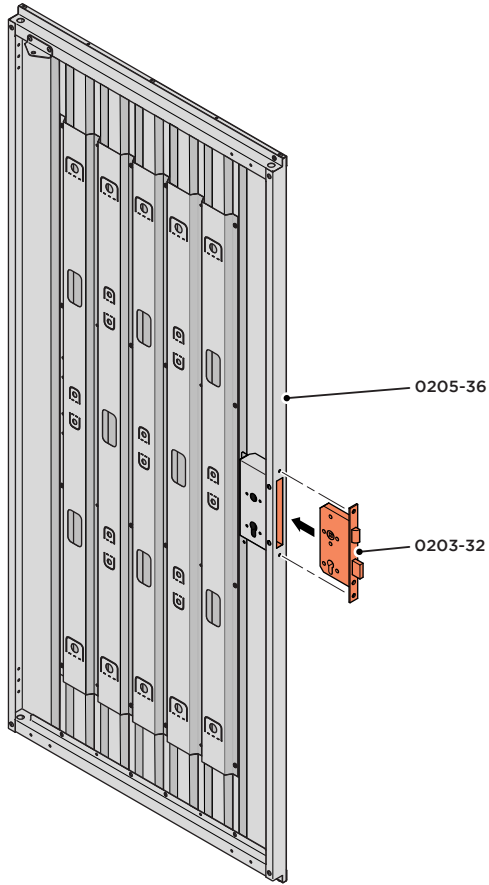

42A

LOCATE EURO MORTICE LOCK 0203-32 RIGHT-HAND DOOR APERTURE AS SHOWN.

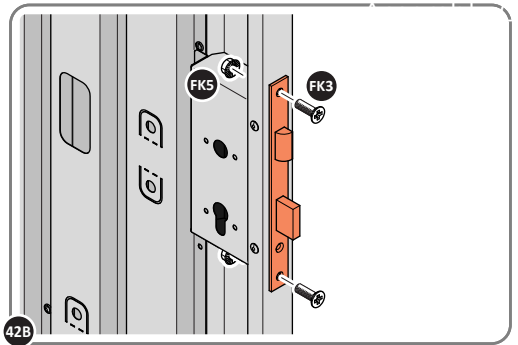

42B

SECURE EURO MORTICE LOCK 0203-32 AT x2 LOCATIONS INDICATED ABOVE. SEE FOLLOWING DATA SHEET FOR COMPLETION OF MORTICE LOCK INSTALLATION.

ASSEMBLY STAGE 42 CONTINUED

LOCATE AND SECURE RIGHT-HAND DOOR ASSEMBLY 0205-36 FURNITURE.

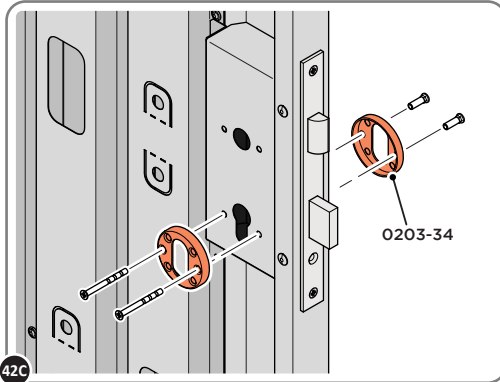

42C LOCATE AND SECURE EURO ESCUTCHEON 0203-34 AS SHOWN.

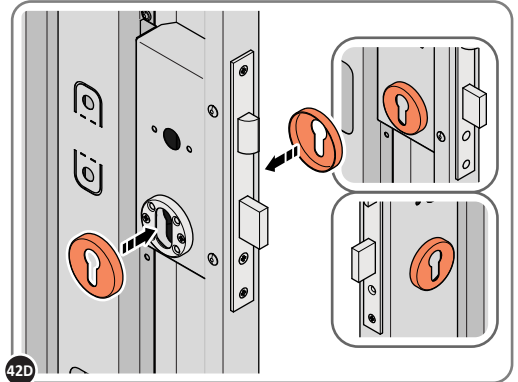

42D LOCATE EURO ESCUTCHEON COVER 0203-34 ONTO EURO ESCUTCHEON AS SHOWN. PLEASE NOTE: THESE ARE PUSHED ON AND WILL CLICK INTO PLACE.

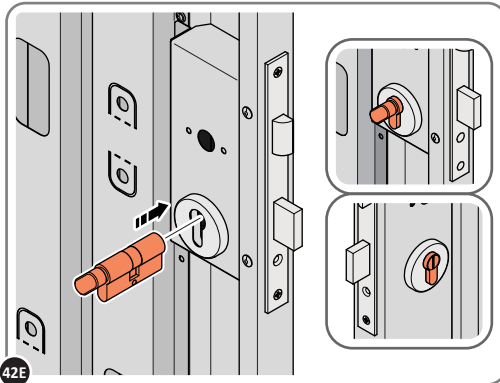

42E LOCATE EURO CYLINDER 0203-36 INTO DOOR APERTURE. IMPORTANT: ENSURE COVER IS FITTED AS SHOWN.

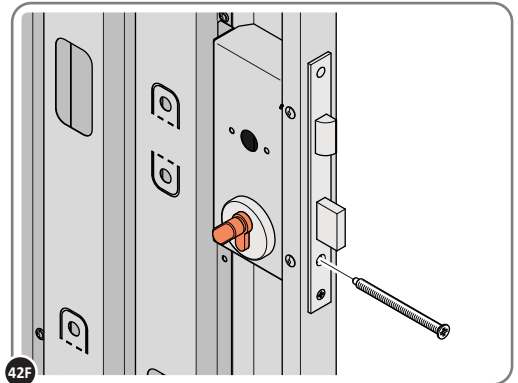

42F SECURE EURO CYLINDER 0203-36 AS SHOWN ABOVE. PLEASE NOTE: FIXING IS PART OF THE EURO MORTICE LOCK ASSEMBLY.

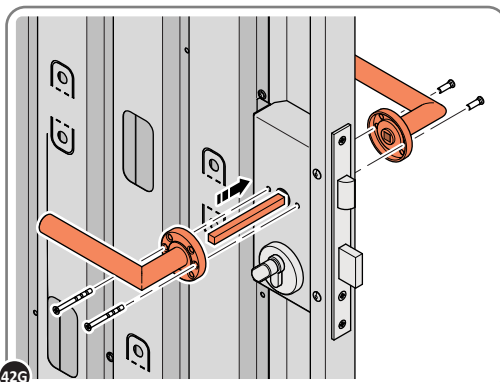

42G LOCATE AND SECURE DOOR HANDLE ASSEMBLY 0203-33 AS SHOWN.

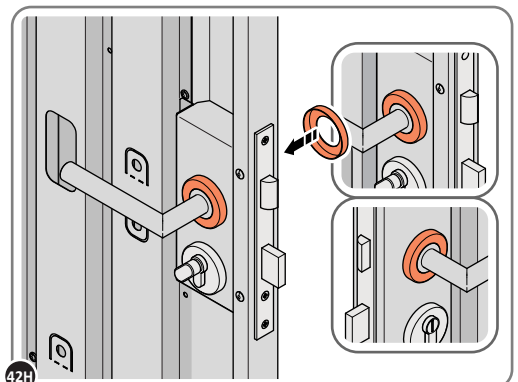

42H LOCATE COVER ONTO DOOR HANDLE AS SHOWN. PLEASE NOTE: THESE ARE PUSHED ON AND WILL CLICK INTO PLACE.

ASSEMBLY STAGE 43

LOCATE AND SECURE LEFT-HAND DOOR ASSEMBLY 0205-37 FURNITURE.

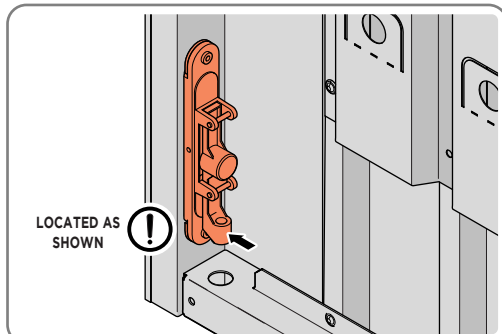
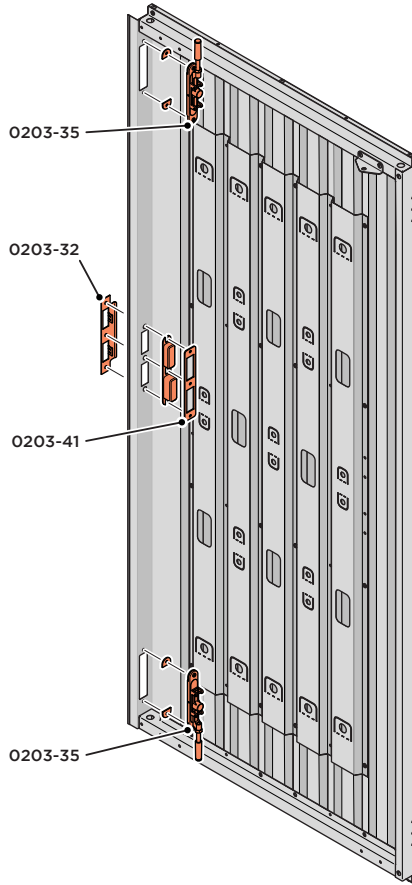

ENSURE THE PLUNGER INDICATED IS FACING THE BOTTOM OF THE DOOR. LOCATE AS SHOWN ABOVE AND SECURE USING ADJACENT FIXING METHOD.

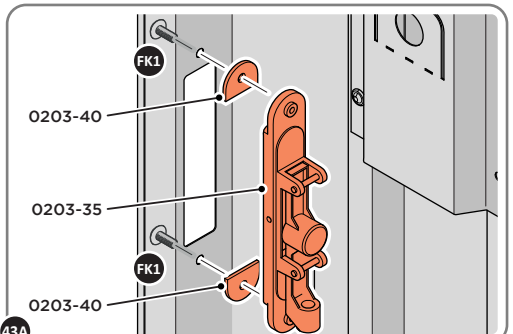

SECURE EACH FLUSH DOOR BOLT ENSURING PLATE PACKER 0203-40 IS LOCATED AS SHOWN ABOVE.

Assembly Guide

ASSEMBLY STAGE 43 CONTINUED

LOCATE AND SECURE LEFT-HAND DOOR ASSEMBLY 0205-37 FURNITURE.

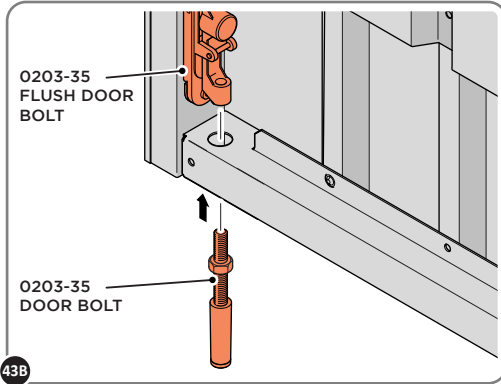

ATTACH DOOR BOLT ONTO FLUSH DOOR BOLT.

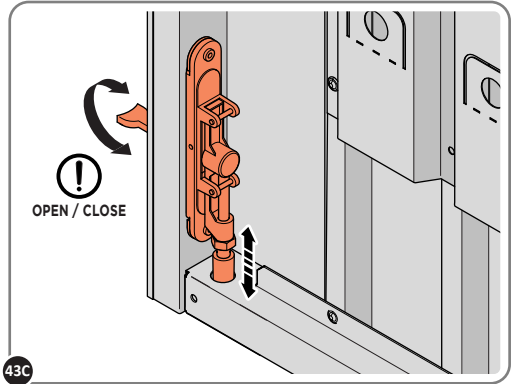

ENSURE FLUSH DOOR BOLT OPENS AND CLOSES.

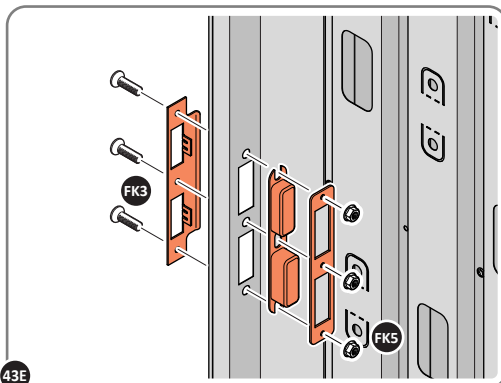
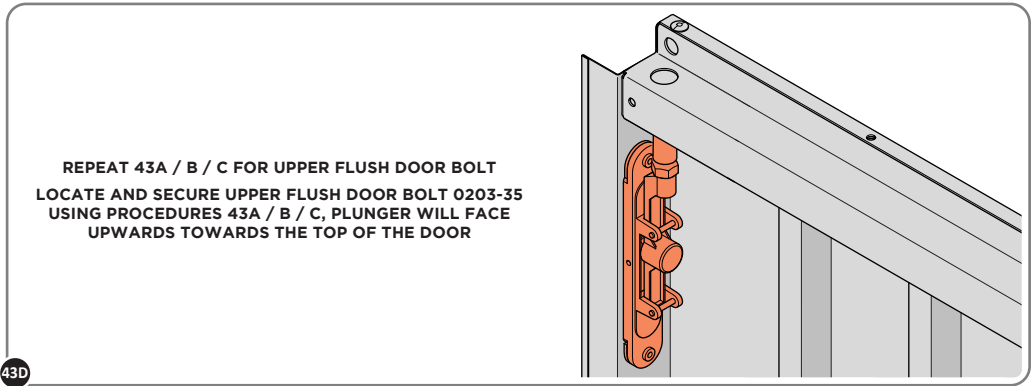

LOCATE AND SECURE EURO MORTICE LOCK 0203-32 AND CATCH PLATE COVER 0203-41 AS SHOWN ABOVE.

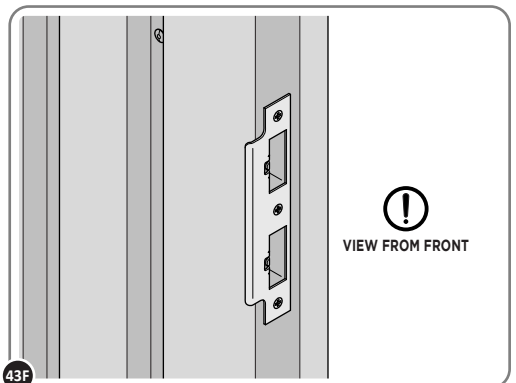

SECURED EURO MORTICE LOCK 0203-32 AS SEEN FROM FRONT.

Assembly Guide

ASSEMBLY STAGE 44

LOCATE AND SECURE A DOOR GROMMET 0203-57 AT EACH LOCATION INDICATED.

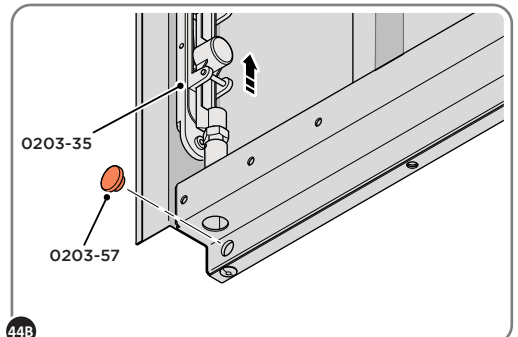
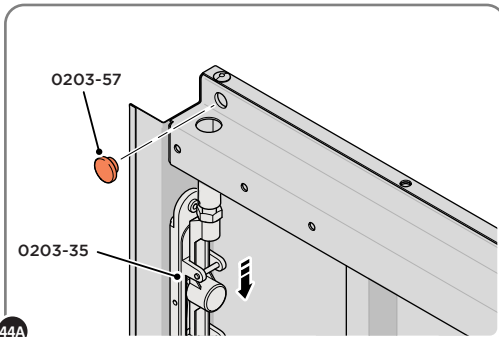
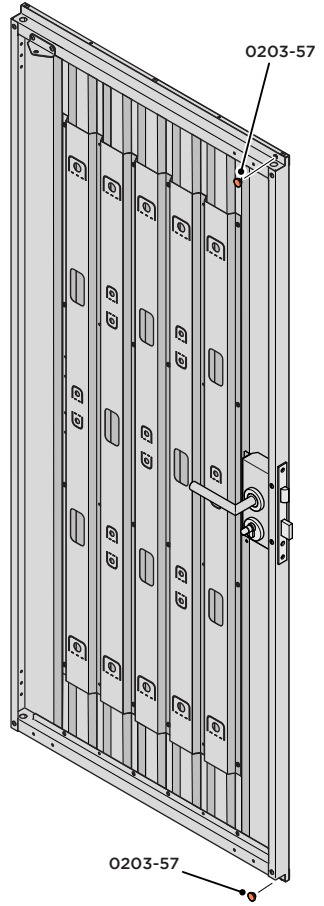
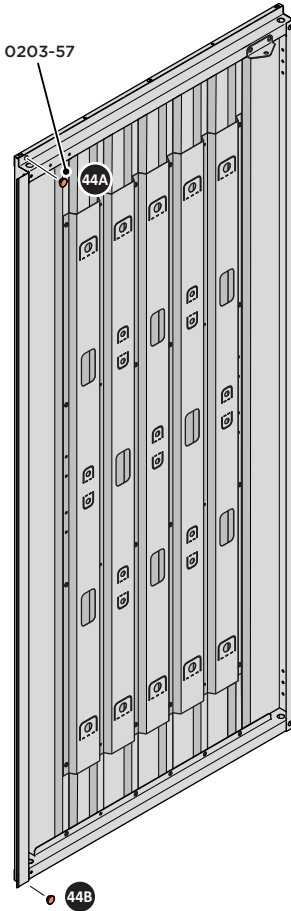

LOCATE DOOR GROMMET 0203-57 AT x2 LOCATIONS INDICATED. PLEASE NOTE: 0203-35 FLUSH BOLTS ARE ALL IN THE UNLOCKED POSITIONS.

LOCATE DOOR GROMMET 0203-57 AT x2 LOCATIONS AS SHOWN. PLEASE NOTE: THESE ARE PUSHED ON AND WILL CLICK INTO PLACE.

Assembly Guide

ASSEMBLY STAGE 45

LOCATE AND SECURE DOOR HINGES ONTO DOOR ASSEMBLIES.

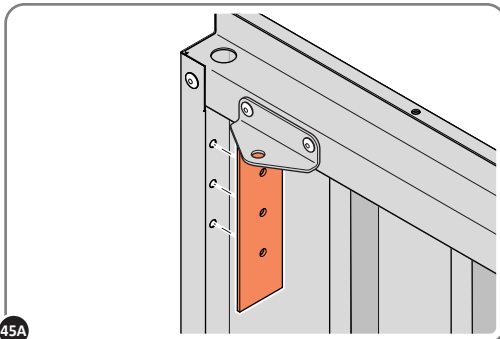
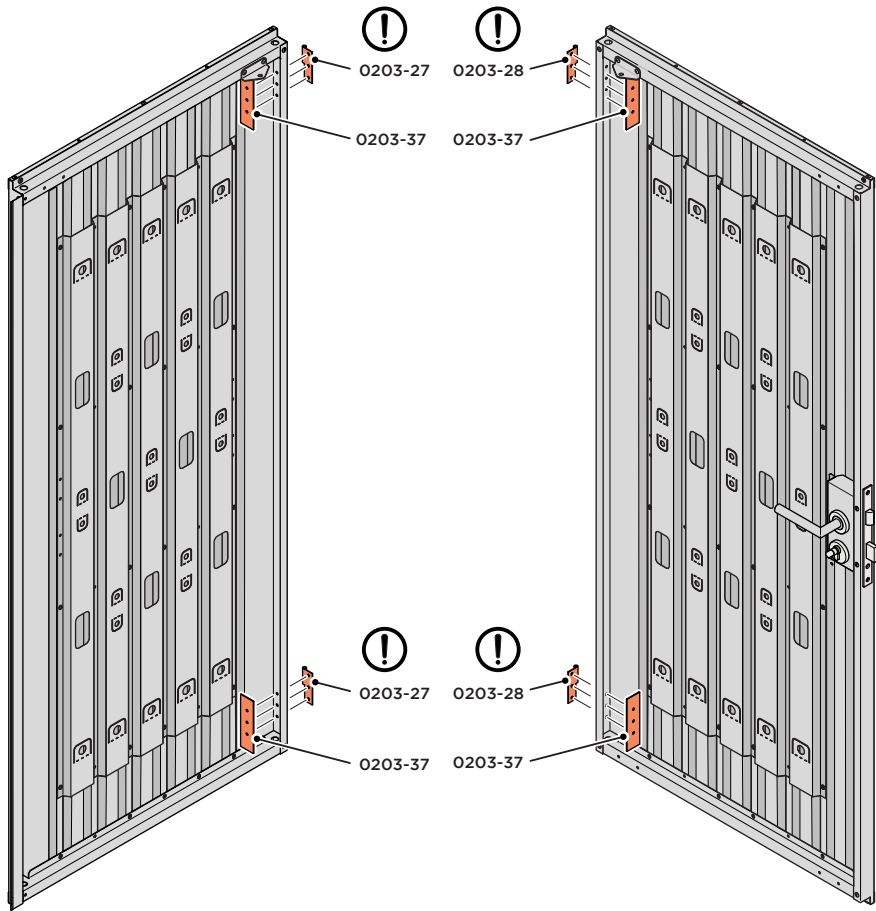

LOCATE DOOR HINGE PLATE 0203-37 WITHIN DOOR AS SHOWN.

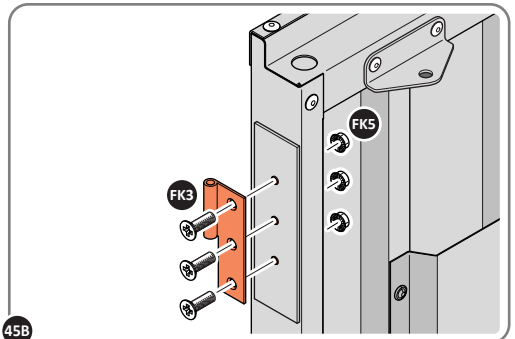

SECURE DOOR HINGE PLATE AND HINGE 0203-27 AND 0203-28 AS SHOWN.
IMPORTANT: ENSURE CORRECT DOOR HINGE IS SECURED TO CORRECT DOOR.

ASSEMBLY STAGE 46

LOCATE AND SECURE DOOR HINGES ONTO LEFT-HAND & RIGHT-HAND DOOR POST.

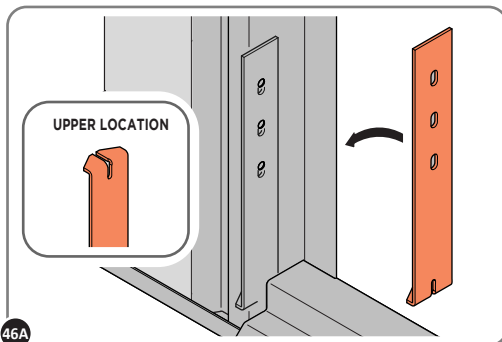
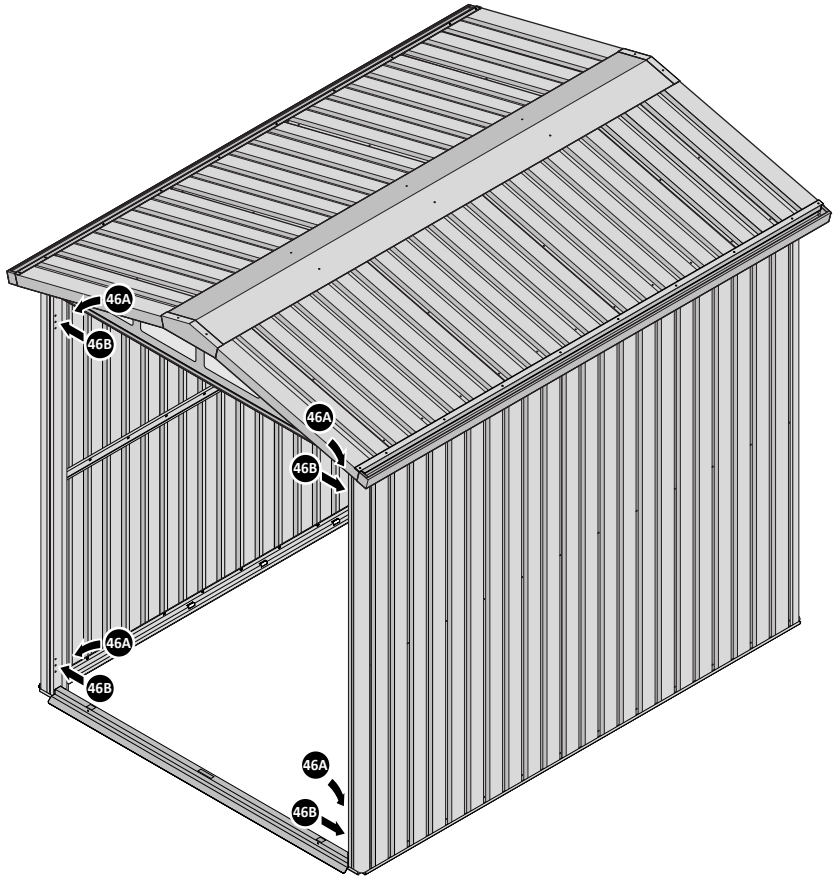

LOCATE DOOR POST PLATE 0203-39 WITHIN DOOR FRAME AS SHOWN. IMPORTANT: ENSURE CORRECT DOOR HINGE IS SECURED TO CORRECT DOOR.

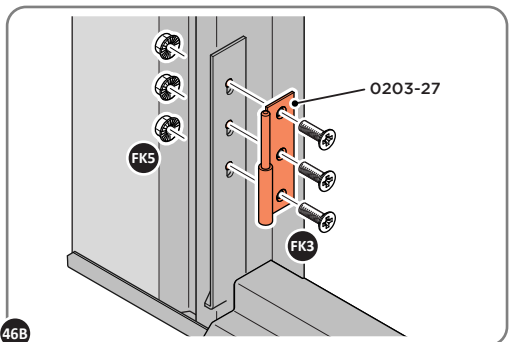

SECURE DOOR POST PLATE AND LEFT-HAND HINGE 0203-27 AS SHOWN. PLEASE NOTE: REPEAT EACH PROCEDURE FOR UPPER LOCATION.

Assembly Guide

ASSEMBLY STAGE 47

LOCATE AND SECURE GAS STRUT BRACKETS 0205-66.

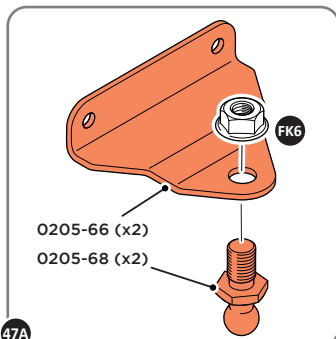

47A SECURE A GAS STRUT BALL JOINT 0205-68 ONTO EACH GAS STRUT BRACKET 0205-66.

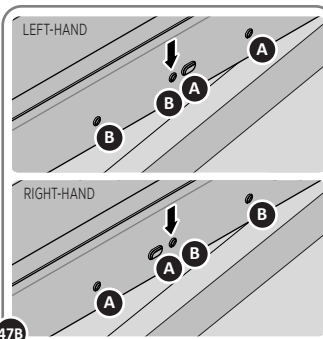

47B DETERMINE DOOR OPENING ANGLE:
A: 90° OPENING OR B: 120° OPENING

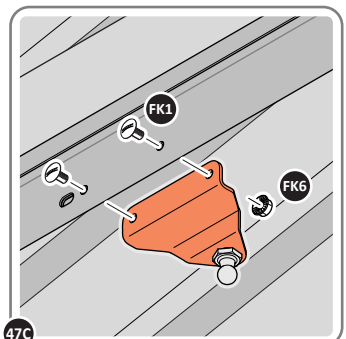

47C ALIGN EACH GAS STRUT BRACKET WITH RELEVANT FIXING HOLES, SECURE USING TYPICAL FIXING METHOD ABOVE.

Assembly Guide

ASSEMBLY STAGE 48

LOCATE DOOR ASSEMBLIES ONTO HINGES.

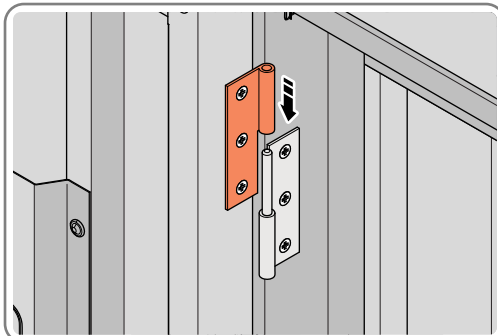
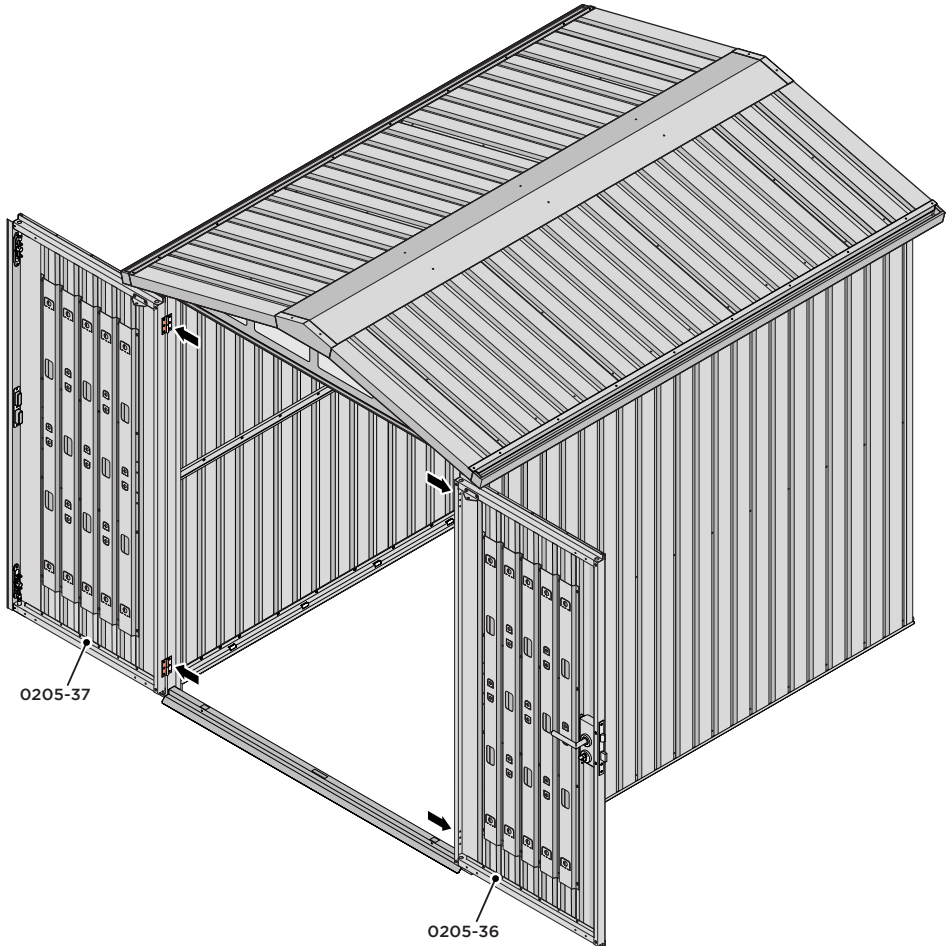

SLIDE EACH DOOR ASSEMBLY ONTO EACH OF THEIR RESPECTIVE HINGES.

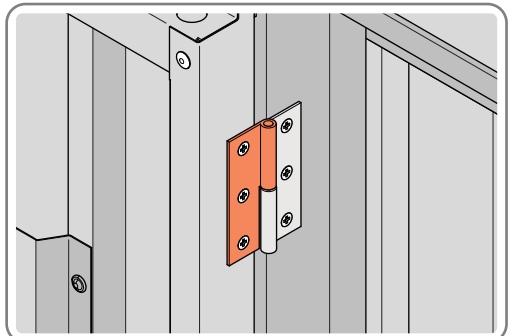

ASSEMBLED DOOR HINGE.

ASSEMBLY STAGE 49

LOCATE AND SECURE GAS STRUT 0205-63.

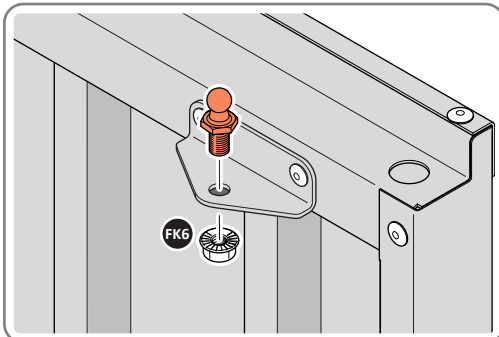

SECURE A GAS STRUT BALL JOINT 0205-68 ONTO EACH GAS STRUT BRACKET THAT IS PRE-RIVETED ONTO EACH DOOR ASSEMBLY.

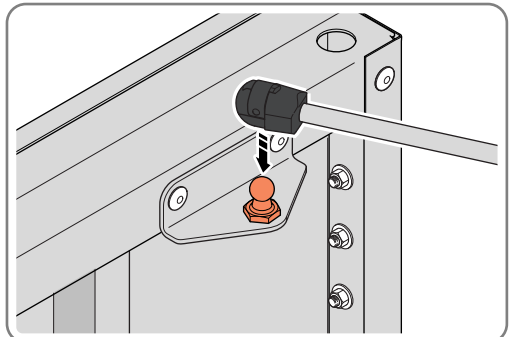

FIX EACH GAS STRUT 0205-63 ONTO RELEVANT GAS STRUT BALL JOINTS. **PLEASE NOTE: PUSHES DOWN ON DOOR AND UPWARDS ON DOOR FRAME.**

ASSEMBLY STAGE 50

LOCATE AND SECURE SHELF ASSEMBLY 0205-38.

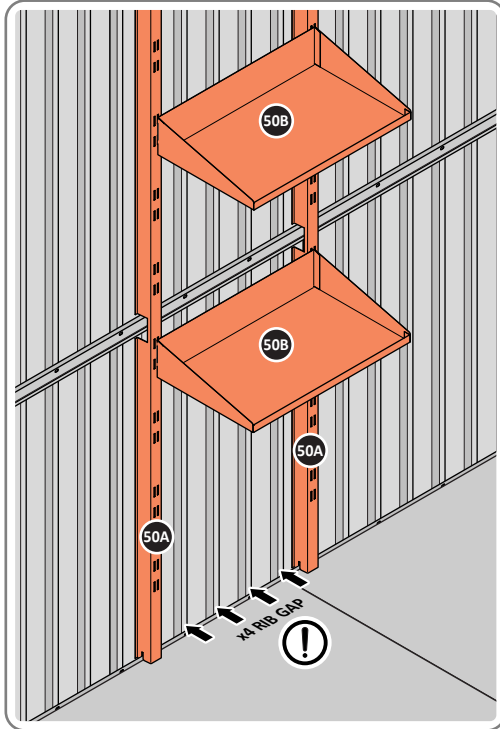

THE SHELF ASSEMBLY CAN BE LOCATED AS DESIRED, PLEASE DETERMINE THE MOST SUITABLE LOCATION AND ASSEMBLE AS SHOWN IN FIG.50A & 50B.

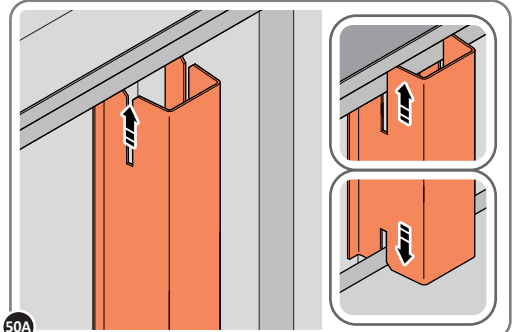

50A

SLIDE SHELF POST UP INTO ROOF FRAME, ONCE THERE IS ENOUGH CLEARANCE AT THE BOTTOM LOCATE SHELF POST OVER FLOOR FRAME AND LOWER.

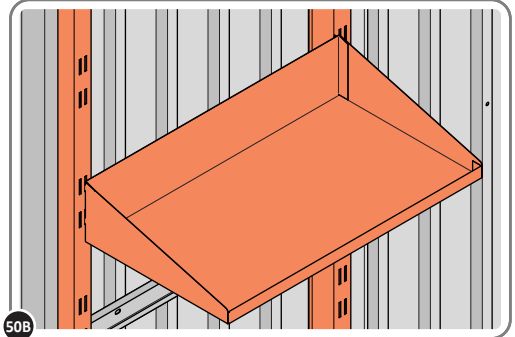

50B

LOCATE EACH SHELF 0205-38-02 ONTO SHELF POST AS DESIRED. PLEASE NOTE: THE SHELF SIMPLY HOOKS ONTO THE POST.

ASSEMBLY STAGE 51

LOCATE TOOL HANGERS 0205-39 WITHIN SHED AS DESIRED LOCATION.

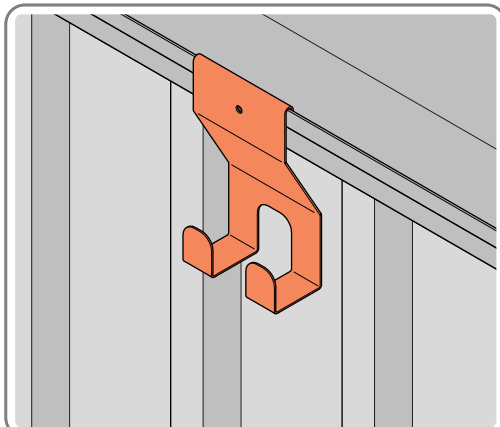

HOOK EACH TOOL HANGER 0205-39 ONTO ROOF FRAME AT DESIRED LOCATION.



IMPORTANT

ADJUST ALL COMPONENTS FOR BEST POSSIBLE FIT AND TIGHTEN ALL FASTENERS.

ONCE ALL FASTENERS HAVE BEEN CHECKED AND ARE SECURE THE ASSEMBLY IS COMPLETE

WE RECOMMEND YOU ANCHOR YOUR SHED TO A SOLID CONCRETE BASE, GUIDANCE CAN BE FOUND ON PAGE '4'

Caring for your HEX Living product

Your **HEX Living product** is designed to stand the test of time, which is why we're happy to offer a **lifetime warranty** on our products. With zero maintenance required, simply assemble your HEX Living product, and enjoy putting it to great use in your garden.

Periodically, you might want to give your product a clean, these simple care tips are not essential to the performance of your product:

- Remove surface dirt with plain water using a jet wash or sponge, the coating on our products will ensure dirt or mud simply wipes away.
- If you've purchased a HEX Living metal storage solution, periodically clear the roof of fallen leaves.
- If your product has guttering, remove leaves and garden debris as you would on your home.

Ensure you have registered your HEX Living product

Using the unique serial number found on the cover of this document, please visit www.hexliving.co.uk to register your product and access the HEX Living lifetime warranty and video instructions.

Customer Service: +44 (0) 1889 272 056



Doc Ref: 699-0808A/A