

# **10 x 6 Large Metal Storage Shed**

**Flooring Kit Assembly Guide**

# Assembly Guide - 10 x 6

## PARTS LIST

### WOODEN FLOOR KIT

0212-GREY-FW  
0225-GREEN-FW

Part Ref: 0205-11  
Qty: x1

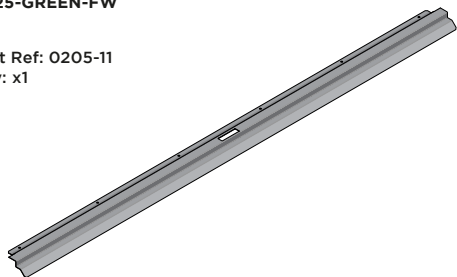

Part Ref: 0212-08  
Qty: x4

Part Ref: 0212-09  
Qty: x1

Part Ref: 0212-10  
Qty: x1

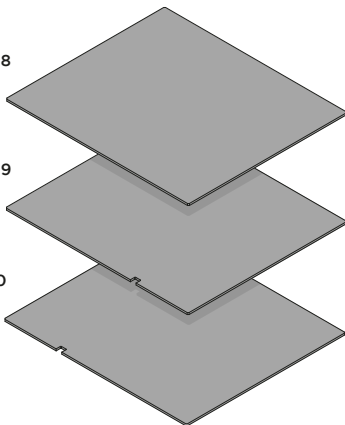

### ALUMINIUM FLOOR KIT

0212-GREY-FM  
0225-GREEN-FM

Part Ref: 0205-73  
Qty: x1

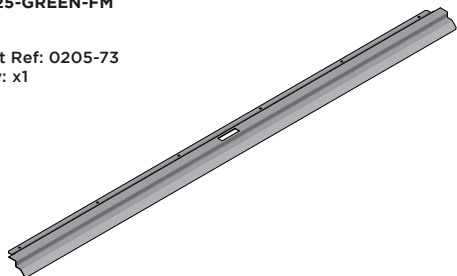

Part Ref: 0212-18  
Qty: x4

Part Ref: 0212-19  
Qty: x1

Part Ref: 0212-20  
Qty: x1

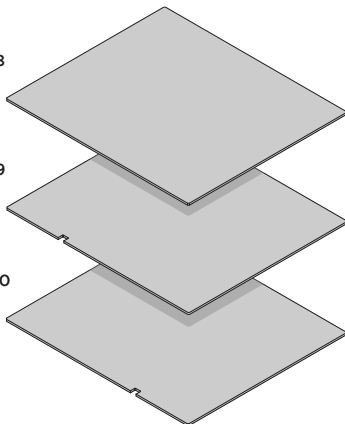

Part Ref: 0212-02  
Qty: x5

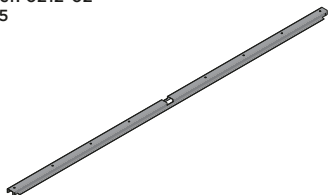

Part Ref: 0205-04  
Qty: x2

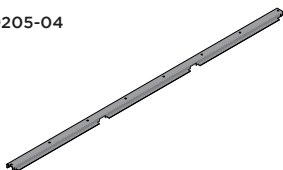

### NEW ASSEMBLY KIT: 0205-71

Part Ref: FK1  
3.9 x 22mm Self Drilling Screw  
Qty: x26

Part Ref: FK2  
No.8 x 13mm Eco Fix  
Qty: x7



### ORIGINAL ASSEMBLY KIT

Part Ref: FK1  
M4 x 10mm Roofing Bolt  
Qty: x2

Part Ref: FK7  
M4 Serrated Flange Nut  
Qty: x2



# Assembly Guide - 10 x 6

## ASSEMBLY STAGE 1

LOCATE AND REMOVE DOOR STRIP 0205-74

**IMPORTANT:** STAGE 1 IS ONLY RELEVANT IF YOU HAVE PURCHASED A NEW FLOORING KIT, AFTER THE SHED HAS BEEN FULLY ASSEMBLED.

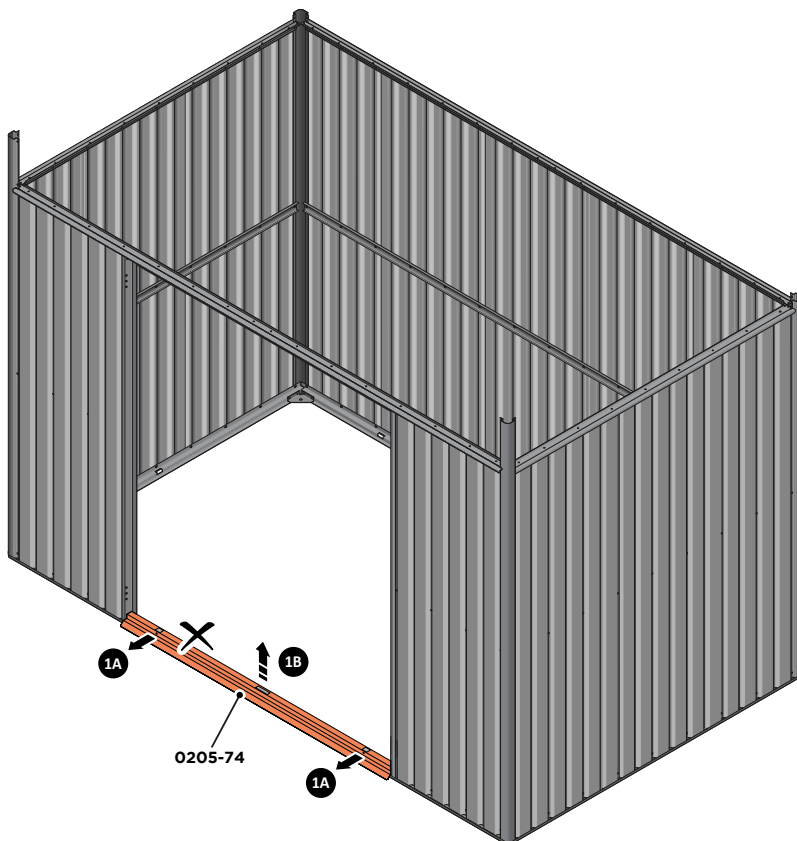

**IMPORTANT:** IF THE FLOORING KIT CAME SUPPLIED WITH THIS PRODUCT, PLEASE IGNORE ASSEMBLY STAGE 1 AND MOVE ONTO STAGE 2 INSTRUCTIONS.

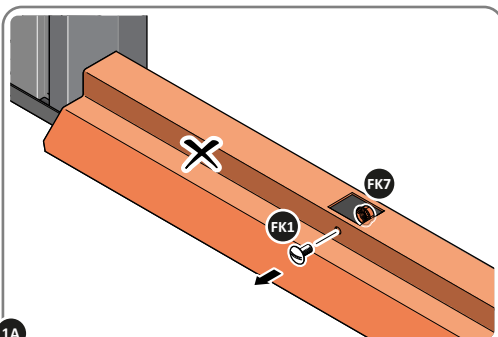

1A REMOVE NUT AND BOLT FROM DOOR STRIP AT x2 LOCATIONS INDICATED.

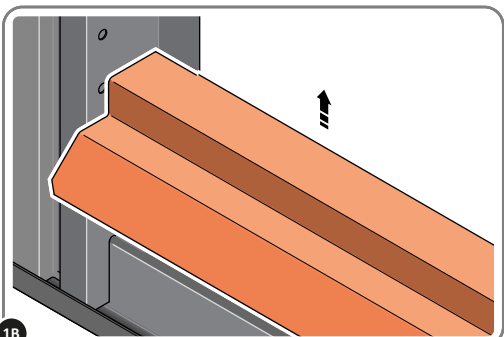

1B REMOVE DOOR STRIP 0205-74 FROM FLOOR PANELS AS SHOWN.

# Assembly Guide - 10 x 6

## ASSEMBLY STAGE 2

LOCATE AND SECURE A FLOOR BRACE 0212-02 AT EACH LOCATION INDICATED.

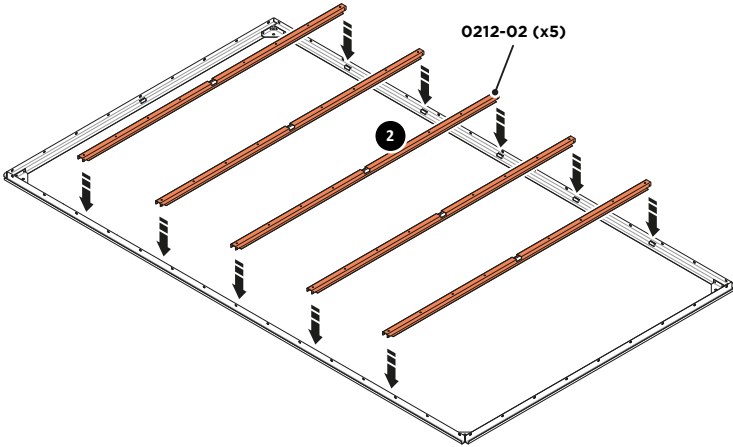

## ASSEMBLY STAGE 3

LOCATE AND SECURE A FLOOR BRACE 0205-04 AT EACH LOCATION INDICATED.

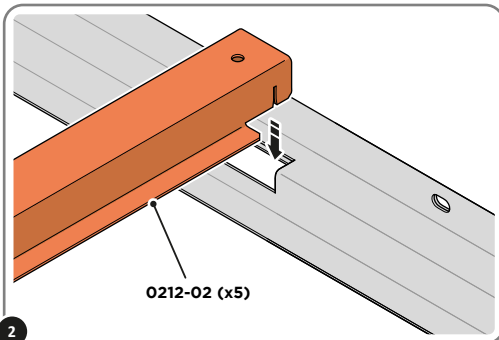
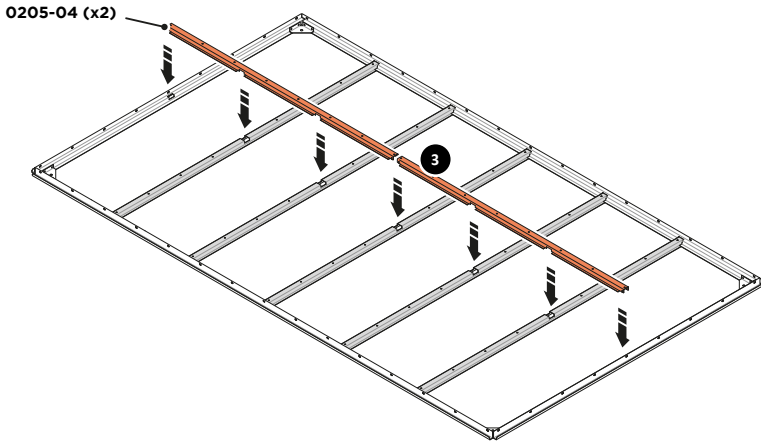

2 SLOT EACH FLOOR BRACE 0212-02 INTO POSITION AS SHOWN ABOVE.

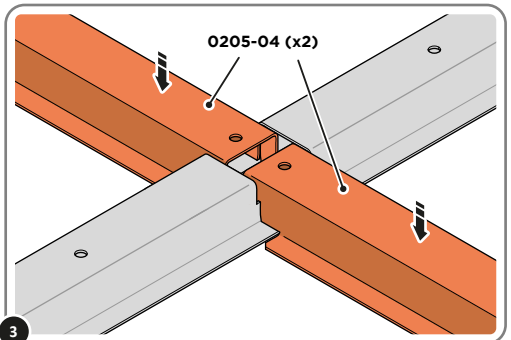

3 SLOT EACH FLOOR BRACE 0205-04 INTO POSITION AS SHOWN ABOVE. PLEASE NOTE: ENSURE TOP OF FLOOR BRACE IS LEVEL WITH TOP OF FLOOR RAIL.

# Assembly Guide - 10 x 6

## ASSEMBLY STAGE 4

LOCATE FLOOR PANELS 0212-08 OR 0212-18.

SLOT FIRST THREE FLOOR PANELS 0212-08 OR 0212-18 INTO THE BACK HALF OF FLOOR FRAME.

**IMPORTANT:** THESE FLOOR PANELS DO NOT HAVE A CUT-OUT. ENSURE THE PATTERN FLOORING IS FACE UP.

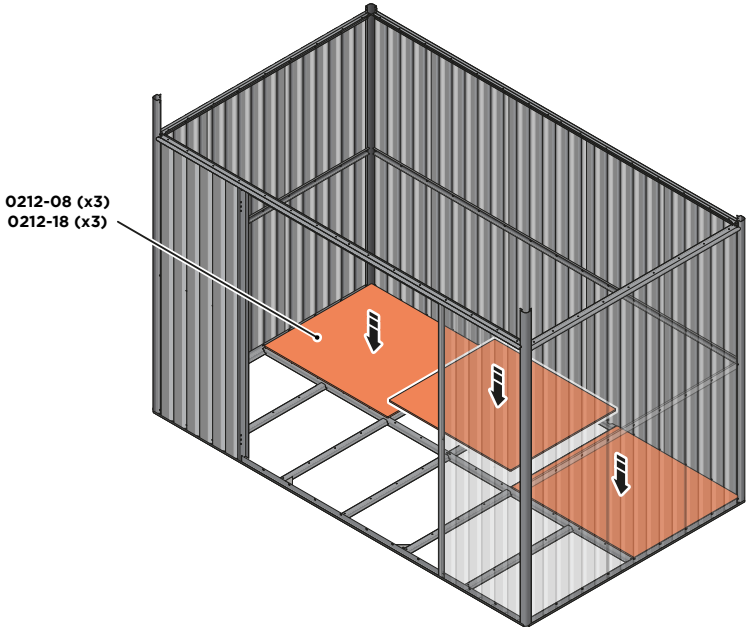

## ASSEMBLY STAGE 5

LOCATE FLOOR PANELS 0212-08 OR 0212-18, 0212-09 OR 0212-20 AND 0212-10 OR 0212-19.

SLOT LEFT AND RIGHT-HAND FLOOR PANELS AND THEN MIDDLE FLOOR PANEL, INTO THE FRONT HALF OF FLOOR FRAME. ENSURE THE PATTERN FLOORING IS FACE UP.

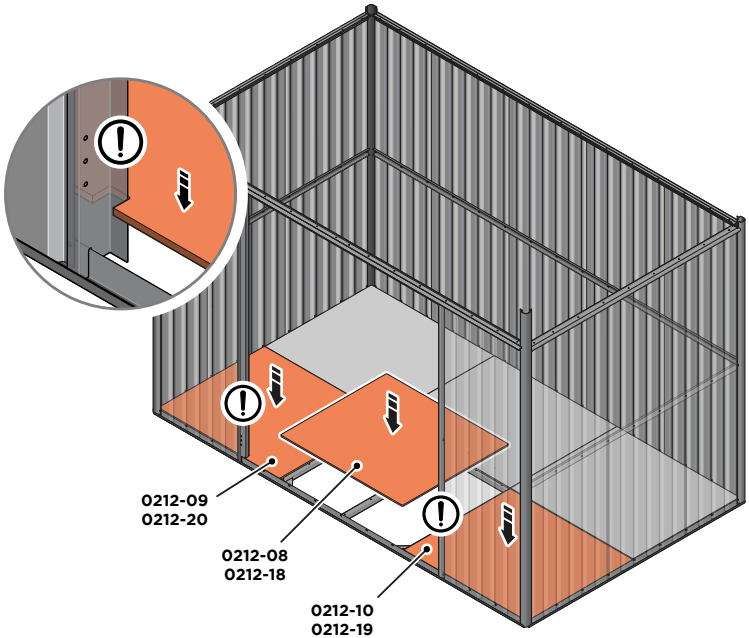

# Assembly Guide - 10 x 6

## ASSEMBLY STAGE 6

LOCATE AND SECURE DOOR STRIP 0205-11 OR 0205-73.

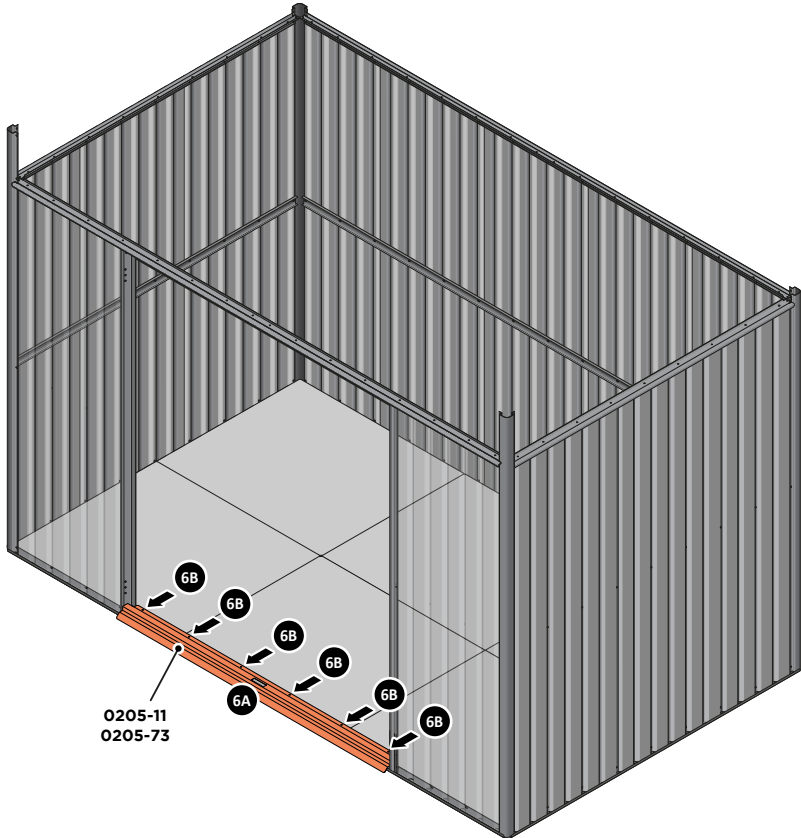

**IMPORTANT:** ONCE FLOOR PANELS ARE POSITIONED CORRECTLY, WE STRONGLY RECOMMEND YOU SECURE THE FLOORING TO THE BASE. FOLLOWING INSTRUCTIONS ON PAGE 7.

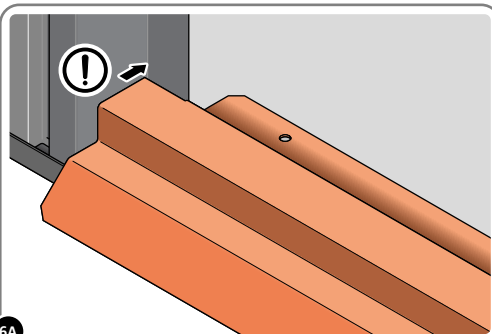

**6A**  
LOCATE DOOR STRIP 0205-11 OR 0205-73 AS SHOWN.  
**IMPORTANT:** ENSURE DOOR STRIP IS PUSHED AGAINST DOOR POST RETURN.

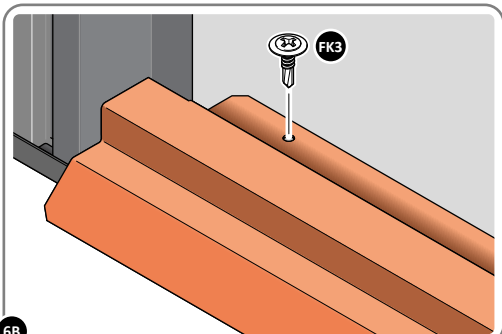

**6B**  
SECURE DOOR STRIP ONTO FLOOR PANELS AT x6 LOCATION INDICATED.  
PLEASE NOTE: THE FIXING USED IS A SELF DRILLING COMPONENT.

# Securing Flooring to Base Cut-out Template

## ASSEMBLY STAGE 7

LOCATE AND SECURE FLOOR PANELS TO SHED BASE

### TOOLS NEEDED



### SINGLE PERSON ASSEMBLY

MOST PROCEDURES WILL NOT REQUIRE TWO PEOPLE BUT IT MAY BE EASIER TO HAVE ASSISTANCE.



### PERSONAL PROTECTION EQUIPMENT

WE ADVISE APPROPRIATE PERSONAL PROTECTIVE EQUIPMENT IS WORN DURING ASSEMBLY INCLUDING EYE PROTECTION AND GLOVES.



### TYPICAL SIX PIECE FLOORING WITH SUGGESTED SCREW LOCATIONS (20), MEASUREMENTS IN (MM)

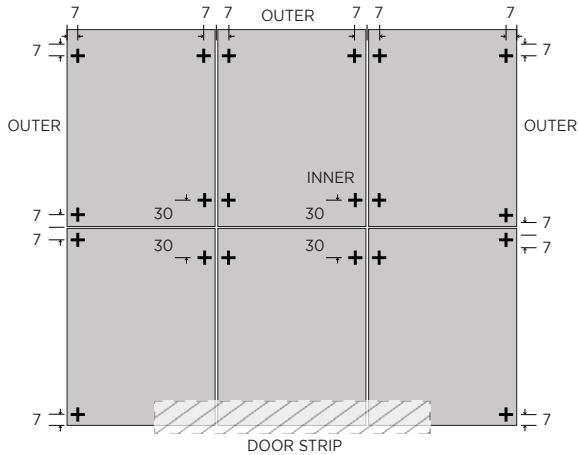

## ASSEMBLY STAGE 7A

MARK OUT FIXING SCREWS LOCATIONS

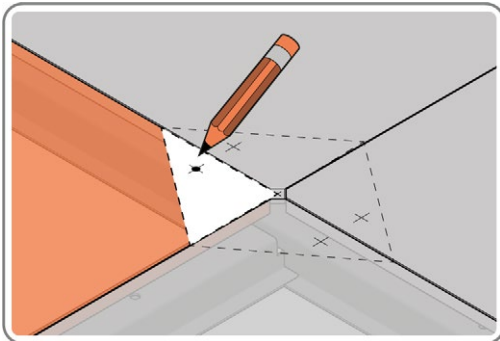

USE TEMPLATE BELOW TO MARK OUT SUGGESTED LOCATIONS FOR SECURING FLOOR TO BASE. (NOTE: ONLY MARK INNER CORNER PANELS - 7 x 30 mm).

## ASSEMBLY STAGE 7B

LOCATE FIXING SCREW AND DRILL TO FLOOR

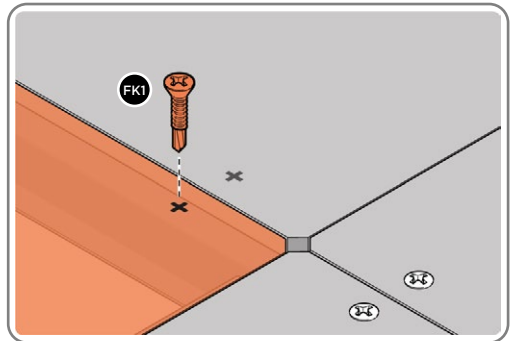

USE DRILL TO SECURE FIXING SCREW FK1 TO EACH FLOOR PANEL MARKED.

## CUT-OUT TEMPLATE GUIDE BELOW

SHOWING SUGGESTED LOCATION HOLES FOR FIXING SCREWS (FK1), FOR DRILLING INTO FLOORING AND BASE.

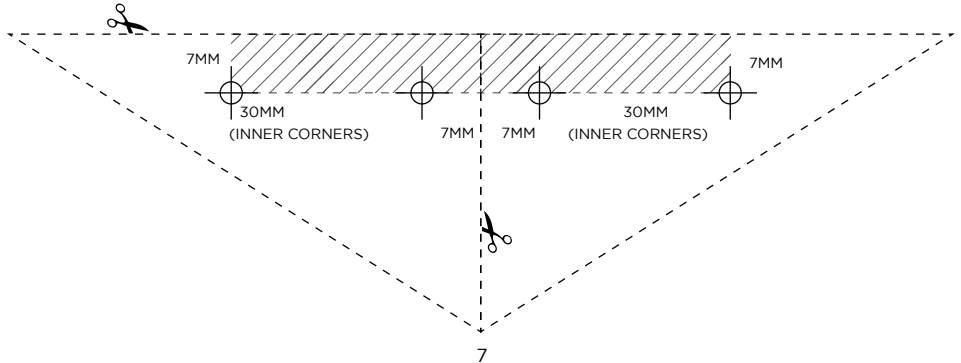

## **Ensure you have registered your product**

If you require any assistance  
our telephone lines are open:

Mon - Fri, 8am - 5pm

**+44 (0) 1889 272 056**