



PERGOLA

Blind Assembly Guide



IMPORTANT: PLEASE REGISTER YOUR HEX LIVING PRODUCT AFTER ASSEMBLY

Using the unique serial number, simply register your product at www.hexliving.co.uk or use the QR code above to access the HEX Living lifetime warranty and online support.



Blind Assembly Guide

ENSURE ALL ITEMS LISTED ARE PRESENT PRIOR TO STARTING ASSEMBLY PROCEDURE
SCALE OF ITEMS WILL VARY TO AID VISUAL IDENTIFICATION.

**PERGOLA
BLIND CASSETTE**
PART REF: A
QTY: X1

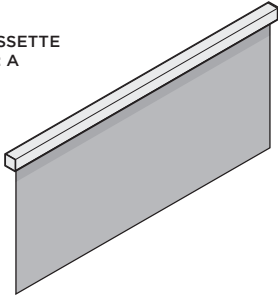

TWO PERSON ASSEMBLY

This well engineered contemporary pergola blind requires 2 people to assemble, time to complete in approximately 30 minutes.



PERSONAL PROTECTION EQUIPMENT

We advise appropriate personal protective equipment is worn during assembly including eye protection and gloves.



Eye Protection



Gloves

WARNINGS AND ADVISORIES

 Select a dry and calm day for your assembly, do not try to install the blind in windy conditions!

SIDE RAIL
PART REF: B
QTY: x2

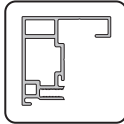
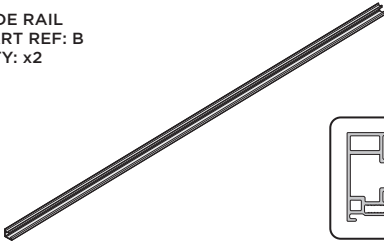

GUIDE STRIP
PART REF: C
QTY: x 2



SIDE RAIL COVER
PART REF: D
QTY: x2

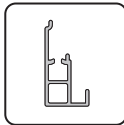
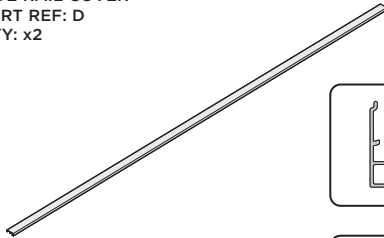

SIDE RAIL END (LH)
PART REF: G
QTY: x1

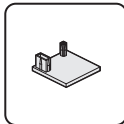

**M4 x 19MM SELF TAPPING
SCREW**
PART REF: E
QTY: x 8

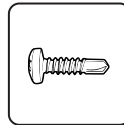

SIDE RAIL END (RH)
PART REF: H
QTY: x1

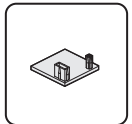
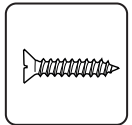

TOOLS REQUIRED

- STEP LADDER (OPTIONAL)
- POWER DRILL
- POZI HEAD DRILL BIT
- POZI HEAD SCREW DRIVER

Blind Assembly Guide

ASSEMBLY STAGE 1

LOCATE SIDE RAILS (PART B) ONTO BLIND CASSETTE TABS (PART A).
SECURE RAIL ENDS (PARTS G & H) TO RAIL BOTTOMS.

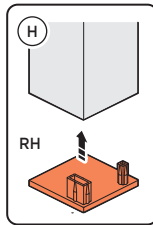
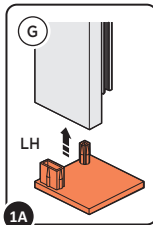
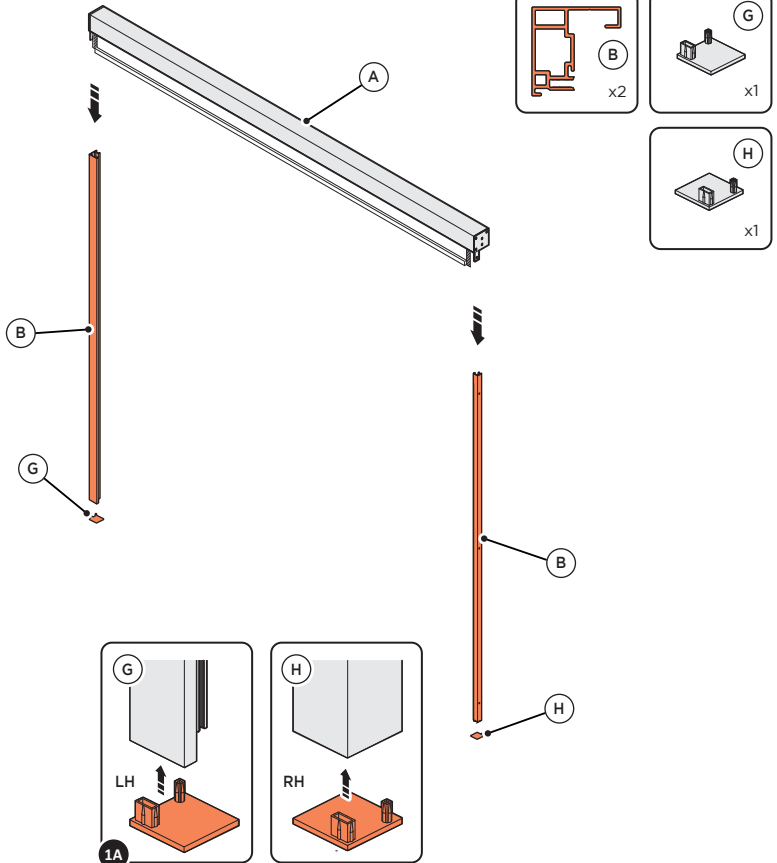

ATTACH END CAPS TO EACH RAIL BASE.

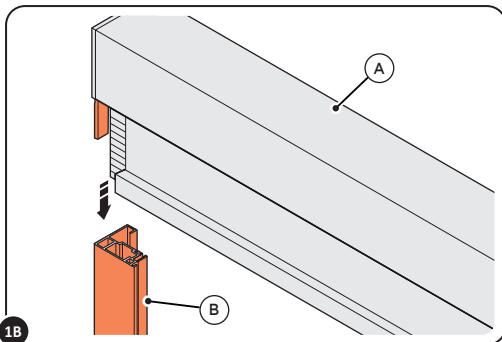

ATTACH BLIND CASSETTE TO SIDE RAIL AS SHOWN ABOVE.

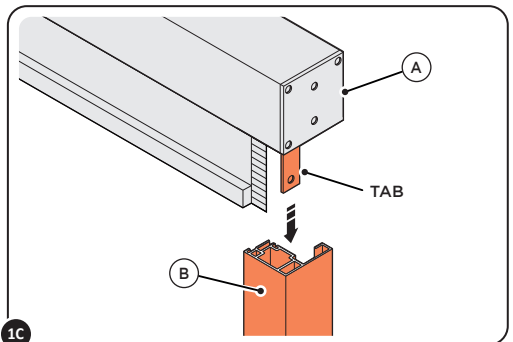

REPEAT PROCEDURE ON THE OPPOSITE SIDE.

Blind Assembly Guide

ASSEMBLY STAGE 2

SECURE BLIND CASSETTE AND SIDE RAILS, BETWEEN THE PERGOLA LEGS.

!
IMPORTANT:
BLIND CASSETTE SHOULD
BE FLUSH WITH EDGE OF
PERGOLA BEAM BEFORE
SECURING

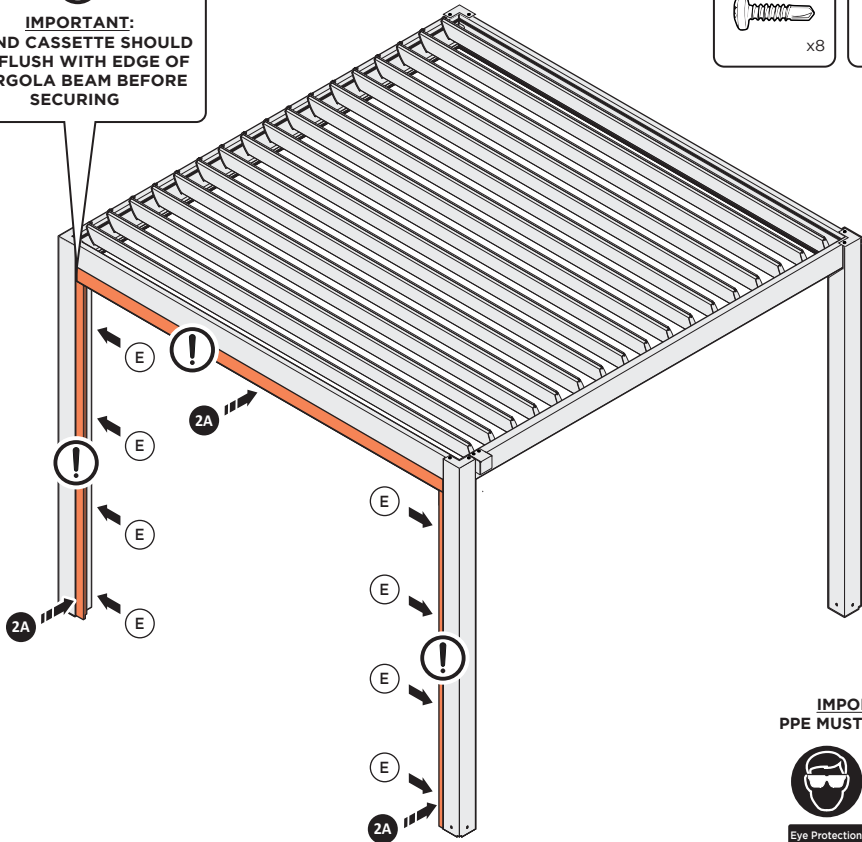
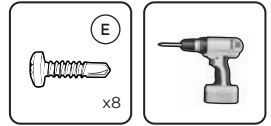

IMPORTANT:
PPE MUST BE WORN!

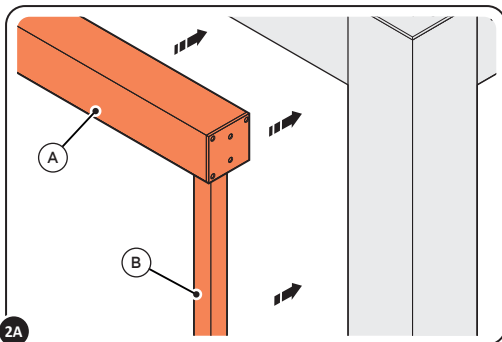

POSITION BLIND CASSETTE AND SIDE RAILS (PARTS A & B) BETWEEN THE PERGOLA LEGS, AS SHOWN ABOVE.

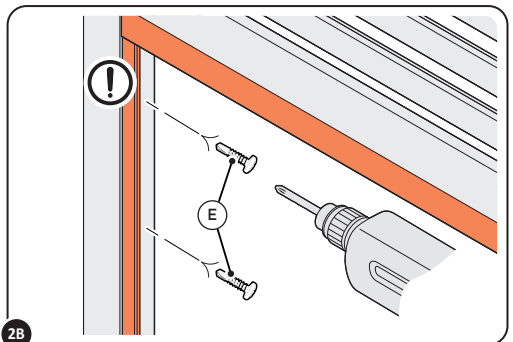

SECURE IN PLACE USING FIXING (E) IN 8 POSITIONS.

Blind Assembly Guide

ASSEMBLY STAGE 3

LOCATE AND SECURE THE GUIDE STRIPS INTO SIDE RAILS.

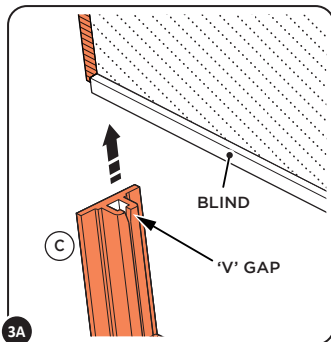
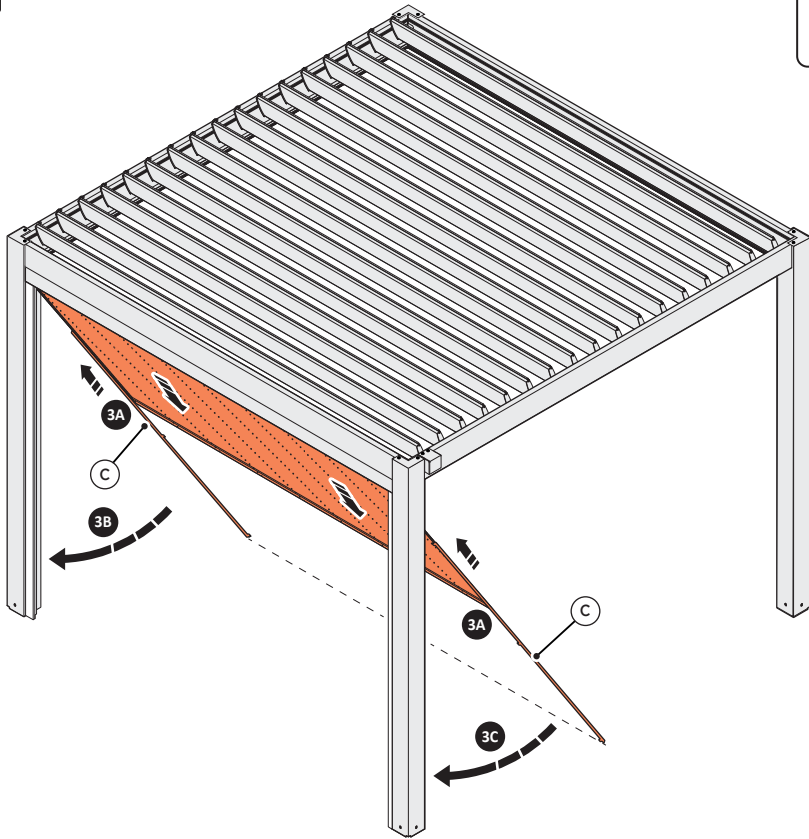
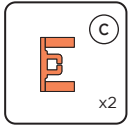

UNWIND THE BLIND APPROX. 50CM, AND INSERT THE GUIDE STRIP (PART C) OVER THE ZIPPER FEATURE ALONG THE EDGE OF THE BLIND.

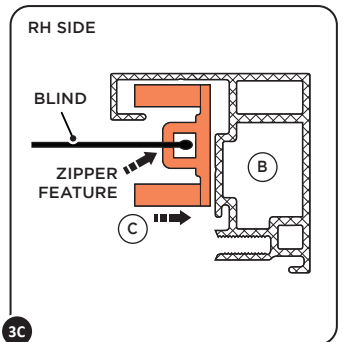
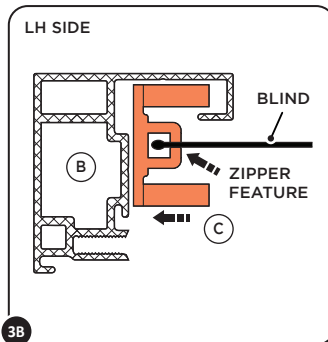

REPEAT PROCEDURE ON THE OPPOSITE SIDE.

Blind Assembly Guide

ASSEMBLY STAGE 4

LOCATE AND SECURE THE SIDE RAIL COVERS (PART D).

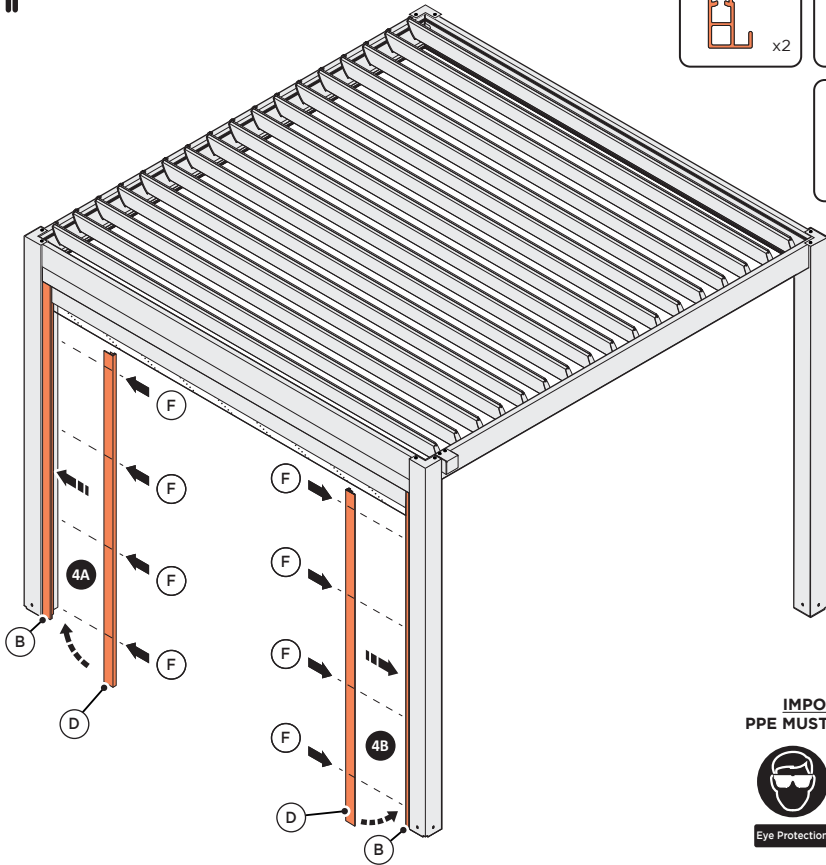
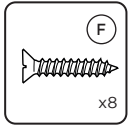
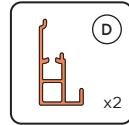

**IMPORTANT:
PPE MUST BE WORN!**



Eye Protection



Gloves

LH SIDE

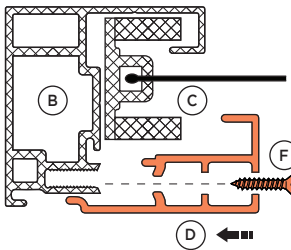

4A

LOCATE SIDE RAIL COVER (PART D) AND SECURE USING SCREWS (PART F), AS SHOWN ABOVE.

RH SIDE

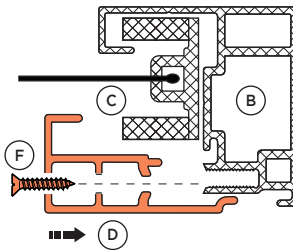

4B

REPEAT PROCEDURE ON THE OPPOSITE SIDE.

FIG.1

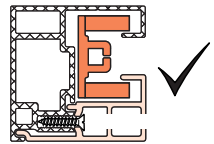
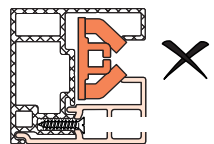

FIG.2



4C

DO NOT TO TRAP (PART C) FIG.2 INSIDE THE SIDE RAILS, AS SHOWN ABOVE.

ASSEMBLY STAGE 5

CHECK THE FUNCTIONALITY OF THE BLIND BY OPERATING IN A UP AND DOWN MOTION SEVERAL TIMES.



PRECAUTIONS 6

WHEN OPERATING THE BLIND, ENSURE BOTH HANDS ARE LOCATED CENTRALLY AS SHOWN BELOW AND NOT TO ONE SIDE AS THIS COULD CAUSE THE BLIND TO JAM.

FIG.3

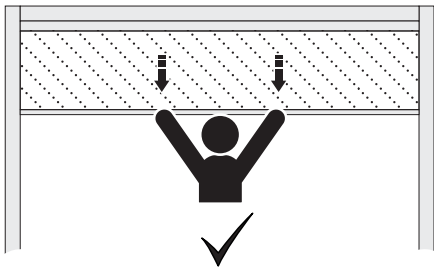
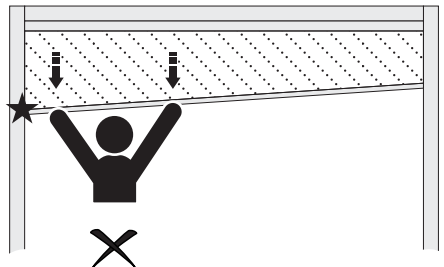
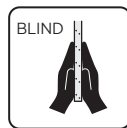

FIG.4



PRECAUTIONS 6 (CONTINUED)

IN THE EVENT OF THE BLIND JAMMING, PLACE YOUR HANDS EITHER SIDE OF THE BLIND AND CAREFULLY MOVE THE BLIND UP OR DOWN UNTIL FREE.



GRIP THE BLIND BETWEEN YOUR PALMS

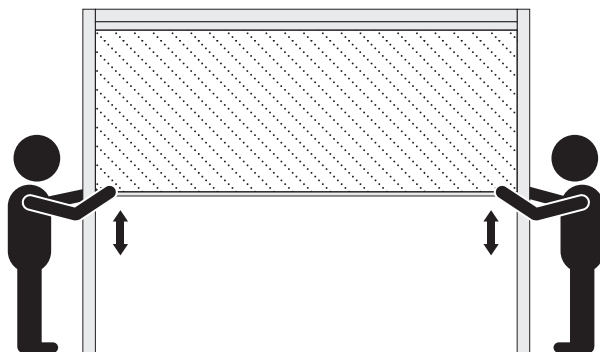

CHECK PERGOLA FRAME FOR SQUARENESS, TO PREVENT BLIND ISSUES.

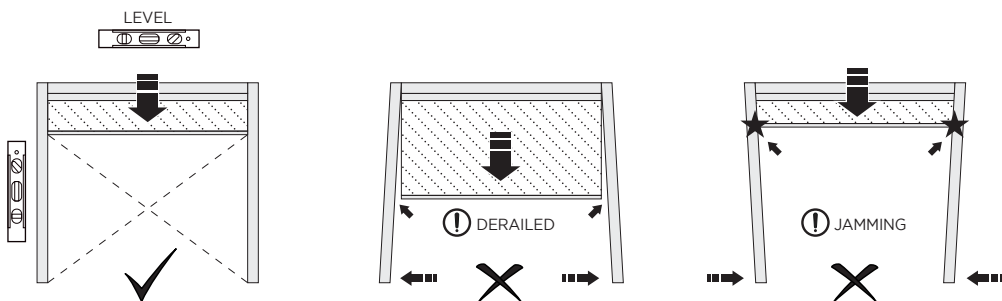

MAINTENANCE TIPS 7

- IF BLIND ISSUES PERSIST CHECK YOUR PERGOLA FRAME FOR SQUARENESS, AND ADJUST IF NECESSARY REFERRING TO THE PERGOLA ASSEMBLY MANUAL.
- ENSURE SIDE RAILS REMAIN FREE OF DEBRIS AND REMOVE ANY VISUAL OBSTRUCTIONS PERIODICALLY.
- IN SOME CASES APPLYING A LIGHT COATING OF A SILICONE-BASED LUBRICANT (I.E. VASELINE) TO THE GUIDE STRIPS WILL HELP IMPROVE THE OPERATION OF THE BLIND.
- IF YOU BELIEVE THERE IS A FAULT, PLEASE CALL THE INSTALLATION COMPANY OR CONTACT OUR HEX LIVING CUSTOMER SERVICE: +44 (0) 1889 272 056.

Blind Assembly Guide

TROUBLE SHOOTING 8

IN THE EVENT OF THE BLIND COMING OUT OF THE GUIDE RAIL, PLEASE FOLLOW THE STEPS BELOW TO RECTIFY THE PROBLEM.

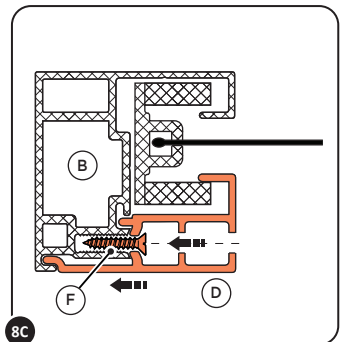
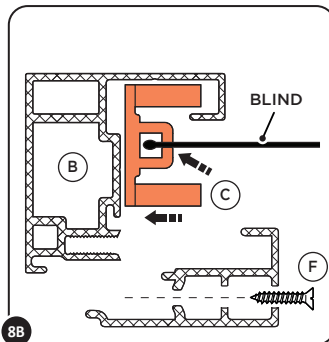
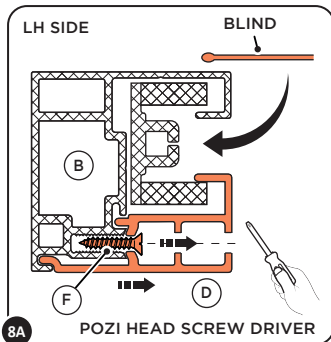
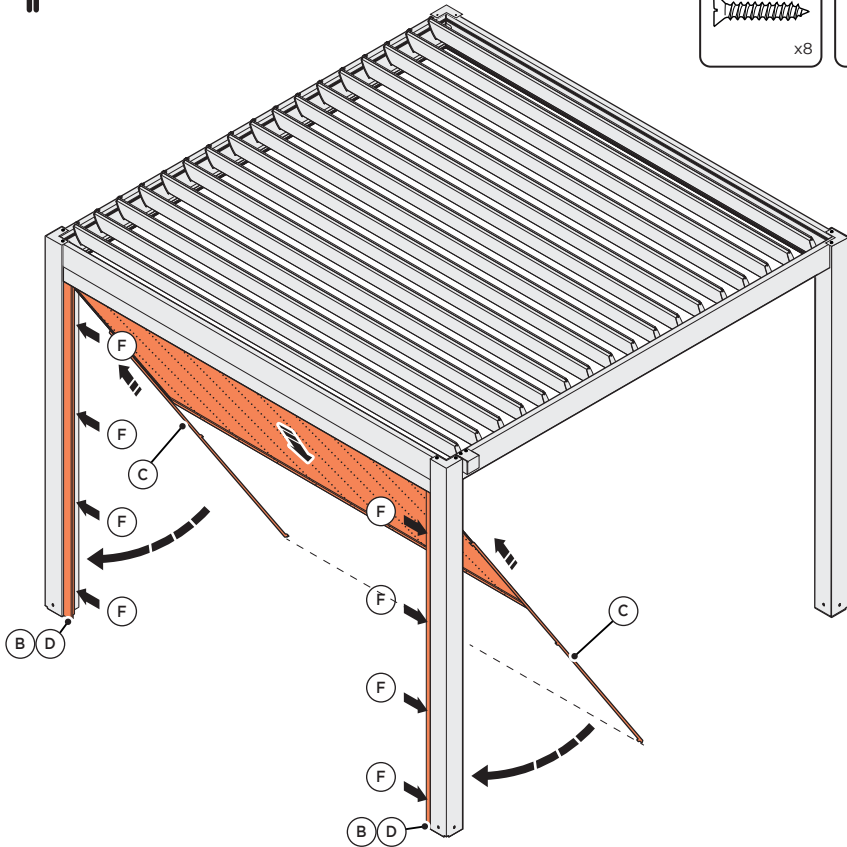
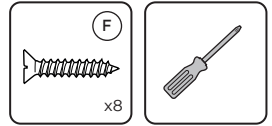

LOCATE SIDE RAIL COVER (PART D), REMOVE SCREWS (PART H) AND DETACH FROM SIDE RAIL (PART B).

FOR THE NEXT STAGE, FOLLOW STEPS ON PAGES 4 & 5 WHICH SHOWS HOW TO SECURE THE BLIND TO THE GUIDE STRIP AND SIDE RAILS.

NOTES

.....

.....

.....

.....

.....

.....

.....

.....

.....

.....

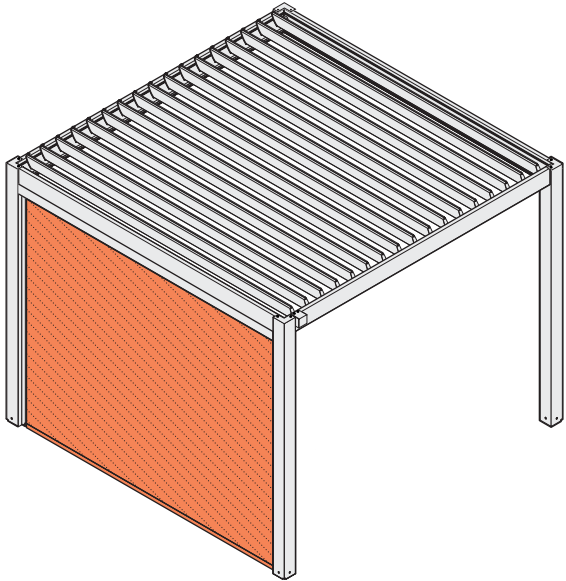



YOUR **HEX LIVING** PRODUCT HAS BEEN DESIGNED TO STAND THE TEST OF TIME, PROVIDING LONG-LASTING PERFORMANCE WITH MINIMAL UPKEEP. THE HIGH-QUALITY TEXTELINE MATERIAL USED IN THESE SCREENS IS FULLY WEATHER-RESISTANT, MEANING IT CAN REMAIN OUTDOORS THROUGHOUT THE YEAR WITH LITTLE MAINTENANCE REQUIRED.

NOTE: DURING EXTREME WEATHER CONDITIONS -PARTICULARLY IN HIGH WINDS OR STORMS, KEEP THE SCREEN FULLY RETRACTED TO PREVENT UNNECESSARY DAMAGE.

TO HELP YOU KEEP YOUR PRODUCT LOOKING ITS BEST AND OPERATING SMOOTHLY, PLEASE FOLLOW THE GUIDANCE BELOW.

GENERAL CARE TIPS

ROUTINE CLEANING

- USE A SOFT BRUSH OR CLOTH TO GENTLY REMOVE DUST, POLLEN, AND SURFACE DEBRIS.
- FOR MORE THOROUGH CLEANING, MIX A MILD DETERGENT WITH LUKEWARM WATER AND APPLY USING A SOFT SPONGE.
- RINSE WITH CLEAN WATER TO REMOVE ANY SOAP RESIDUE.
- ALLOW THE SCREEN TO AIR DRY FULLY BEFORE ROLLING IT BACK INTO THE CASSETTE. CHECK THAT THE SCREEN RETRACTS SMOOTHLY; IF MOVEMENT FEELS STIFF, CLEAN THE SIDE CHANNELS TO REMOVE DEBRIS.

FRAME & CASSETTE CARE

- WIPE ALUMINIUM COMPONENTS WITH A DAMP CLOTH TO MAINTAIN THEIR FINISH.
 - BY APPLYING A SMALL AMOUNT OF PETROLEUM JELLY INSIDE THE SIDE RAILS AT REGULAR INTERVALS, WILL ENSURE SMOOTHER BLIND OPERATION AND REDUCE THE RISK OF JAMMING.
- ⚠ DO NOT USE ABRASIVE PADS OR HARSH CHEMICAL CLEANERS, AS THESE MAY DAMAGE THE PROTECTIVE COATING.

REMOVING STUBBORN MARKS

- FOR MARKS SUCH AS BIRD DROPPINGS OR TREE SAP, ALLOW THE AREA TO SOAK WITH MILD SOAPY WATER FOR SEVERAL MINUTES BEFORE LIGHTLY WIPING.
- ⚠ AVOID SCRUBBING AGGRESSIVELY, AS THIS MAY COMPROMISE THE FABRIC COATING.



Customer Service: +44 (0) 1889 272 056